

# ***Nynja Build manual***

*Version 1.4i*



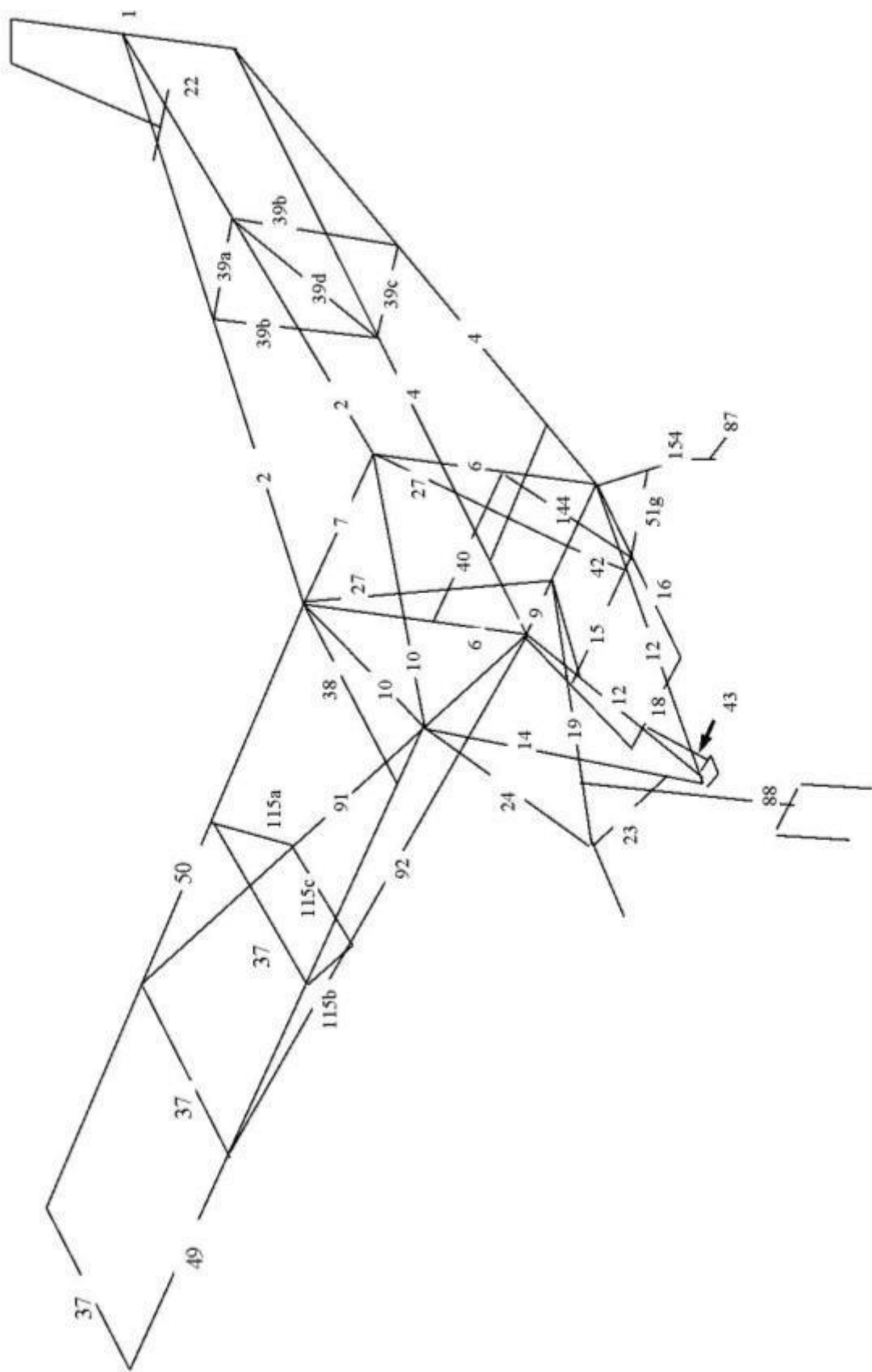
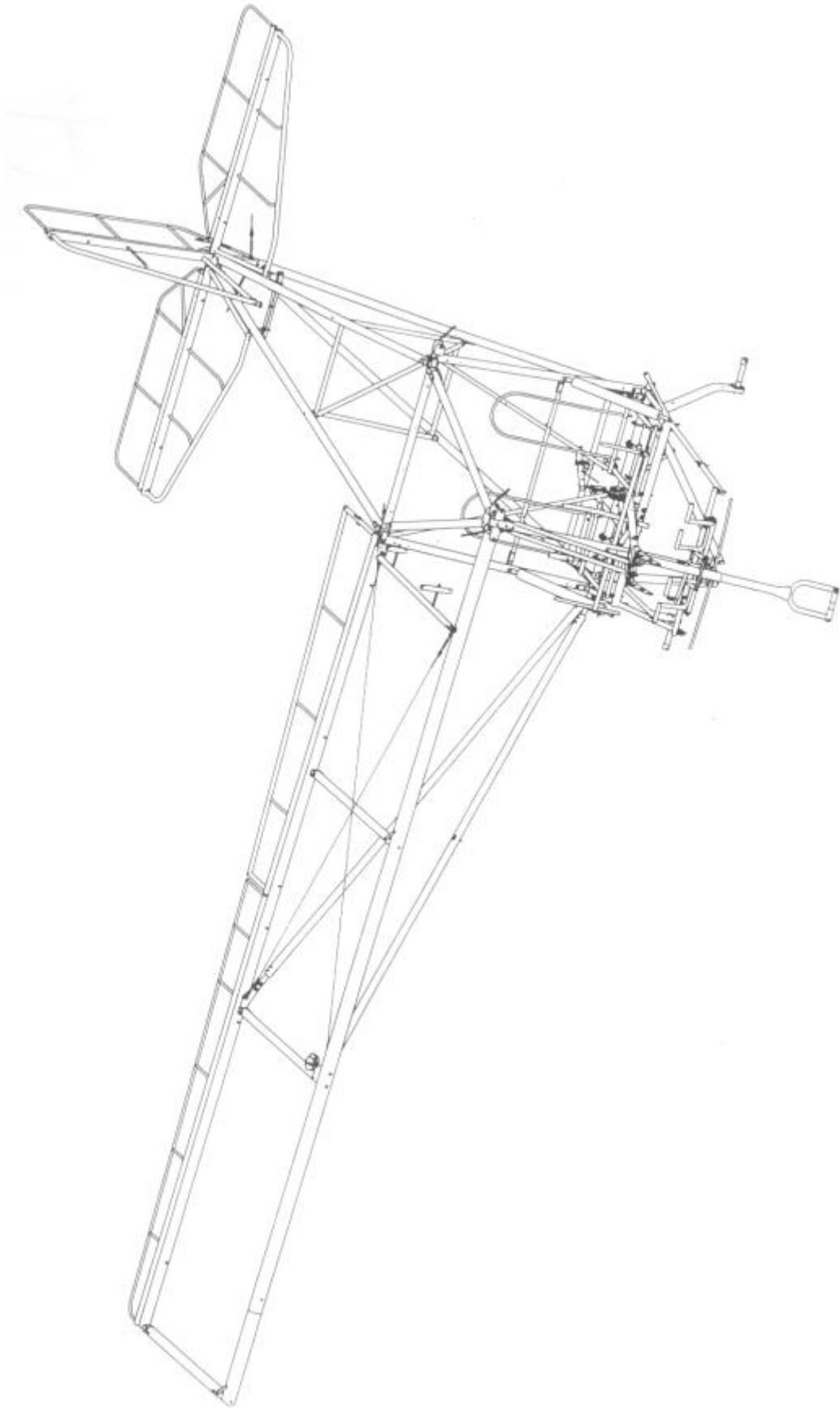


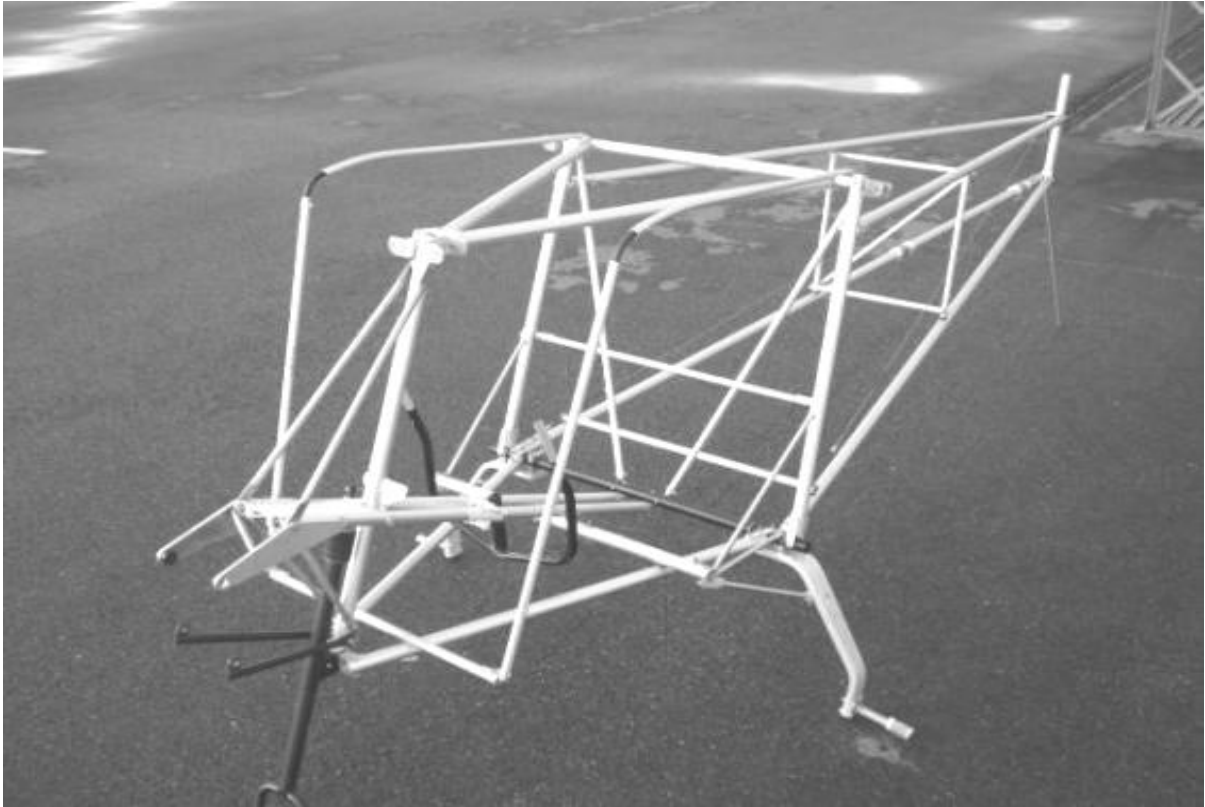
Figure 1 tube numbering scheme.



**Figure 2 Basic frame (Skyraider).**



**Figure 3 uncovered Skyraider frame.**



**Figure 4 Uncovered Nynja frame**



**Figure 5 Nynja fuselage with rear fairings removed**



**Figure 6 Nynja fuselage with rear fairings removed – rear view**



**Figure 7 simply assemble thus!**

# Contents

<b>Introduction.....</b>	<b>10</b>
1.1 How to Build Your Aircraft .....	10
1.2 The BMAA Homebuilt Aircraft System .....	12
1.3 General Assembly Notes .....	14
1.4 Finish.....	18
1.5 Weight .....	20
<b>2. Forward Fuselage.....</b>	<b>21</b>
2.1 Tube Numbering .....	21
2.2 Fuselage frame assembly overview.....	23
2.3 Lower Cabin Triangle .....	25
2.4 Upper Cabin Triangle .....	30
2.5 Rear Cabin Frame.....	33
2.6 Rear cabin frame bracing.....	34
2.7 Engine Supports.....	37
2.8 Floor .....	46
2.9 Rudder Pedals .....	48
2.10 Control Stick Assembly .....	49
2.11 Finishing the Forward Fuselage.....	52
<b>3 Rear Fuselage.....</b>	<b>54</b>
3.1 Tail End .....	54
3.2 Bracing Frame.....	56
3.3 Front End.....	57
3.4 Fuselage bracing cables .....	58
3.5 Tailplane Front Mounting .....	63
3.6 Fuel Tank Support and Flap Handle .....	64
Not Tightening the Bolts and cables! .....	66
<b>4 Undercarriage.....</b>	<b>67</b>
4.1 Wheels .....	67
4.2 Main Undercarriage.....	69
4.3 Nose Gear .....	73
4.4 Brakes .....	77
<b>5. Tail Surfaces .....</b>	<b>80</b>
5.1 Tensioning the Rear Fuselage .....	80
5.2 Elevator Trim Tab.....	81
5.3 Tailplane.....	83
5.4 Rudder.....	87
5.5 Control Cables .....	90
<b>6 Fitting the Rear Fuselage Fairings.....</b>	<b>100</b>
6.1 Preparing the rear fuselage fairings .....	100
6.2 Fitting the rear fuselage fairings.....	101
<b>7. Engine Installation Rotax 912UL/912ULS.....</b>	<b>105</b>
<b>8. Wings.....</b>	<b>110</b>
8.1 Wing Frame.....	110
8.2 Aileron Horn Assembly.....	119
8.3 Attaching the Wings to the Fuselage .....	121
8.4 Aileron Control Cables .....	122
8.5 Flaps.....	126
8.6 Covering the Wings.....	128
8.7 Inserting the Battens .....	136
<b>9. Windscreen Frame .....</b>	<b>138</b>
9.1 Windscreen Frame.....	138

<b>10. Floor pan, firewall and cowlings .....</b>	<b>143</b>
10.1 Floor pan .....	143
10.2 Firewall and scuttle moulding.....	146
10.3 Engine cowlings .....	149
<b>11. Engine Ancillaries .....</b>	<b>154</b>
11.1 CKT twin outlet exhaust fitting .....	154
11.2 Oil cooling.....	156
11.3 Water cooling .....	160
<b>12 Fuel System .....</b>	<b>163</b>
12.1 Fuel lines and connections.....	163
12.2 Engine compartment .....	164
12.3 Fuel Tanks.....	165
.....	165
12.4 Fitting instructions for HADS Optional Mod 33 – Large diameter balance pipe between fuel tanks.....	166
Overview .....	166
Parts: .....	166
Fitting.....	167
12.5 Fuel tank load spreader bars .....	168
12.6 Fuel tank securing straps .....	168
12.7 Fuel tank connections .....	169
12.8 Fuel filler.....	171
<b>13 Instrument panel .....</b>	<b>172</b>
<b>14 Throttle and choke .....</b>	<b>176</b>
14.1 Fitting the firewall brackets.....	176
14.2 Preparing the support angles .....	178
14.3 Throttle torque tube.....	182
14.4 Throttle levers .....	184
14.5 Balance spring, cables and friction. ....	186
14.6 Choke cables .....	189
<b>15 . Instruments.....</b>	<b>192</b>
15.1 Pitot-Static System.....	192
<b>16 Electrical System.....</b>	<b>194</b>
16.1 Soft start wiring .....	198
16.2 Wiring General Points .....	199
16.3 Low Current and Instrument Wiring .....	199
16.4 Battery .....	201
<b>17 Windscreen and rear windows.....</b>	<b>203</b>
17.1 Windscreen .....	203
17.2 Rear windows.....	210
<b>18 Doors.....</b>	<b>212</b>
18.1 Keeping out the drafts. ....	212
18.2 One Piece Door.....	214
18.3 Two Piece Door.....	220
.....	220
<b>19 Tail surfaces again .....</b>	<b>231</b>
19.1 Trimmer system .....	231
<b>20 Centre console. ....</b>	<b>237</b>
<b>21 Seats and Seatbelts.....</b>	<b>241</b>
21.1 Seats .....	241
21.2 Seatbelts .....	244



<b>22</b>	<b>Fitting the teardrop wheel spat option.</b>	<b>245</b>
	Nose Wheel.....	245
	Main Wheel spats.....	246
<b>23</b>	<b>Fairings</b>	<b>250</b>
23.1	Lower Fin Fairing .....	250
23.2	Upper Fin Fairing .....	250
23.3	Wing Root Fairings.....	252
23.4	Cable Exit Fairings .....	252
23.5	Tailplane Leading Edge Fairings .....	253
23.6	Wingstrut end Fairings (Socks).....	253
23.7	Wingtip Fairings .....	254
<b>24</b>	<b>Aerofoil Profile Support Blocks</b>	<b>256</b>
<b>25</b>	<b>Fitting the heater option</b>	<b>258</b>
<b>26.</b>	<b>Fitting the storage side pockets.....</b>	<b>260</b>
<b>27</b>	<b>Fitting the Nynja rear thermal screen</b>	<b>261</b>
<b>28.</b>	<b>Preparing for Flight</b>	<b>263</b>
28.1	Airframe.....	263
28.2	Aerofoil Jury struts .....	263
28.3	General checks .....	265
28.4	Baggage Bag .....	265
28.5	Controls .....	266
28.6	Powerplant .....	269
28.7	Weight and Balance .....	271
28.8	Placards .....	272
28.9	Test Flying.....	272
<b>29</b>	<b>Additional Information</b>	<b>274</b>
29.1	Example BMAA Homebuilt Registration Form .....	274
29.2	Wire-locking.....	276
<b>30</b>	<b>Index</b>	<b>280</b>
<b>31</b>	<b>. Amendments</b>	<b>283</b>

## Introduction

### 1.1 *How to Build Your Aircraft*

Building the Nynja is a fairly straightforward process, but it can be made much more difficult than necessary if one basic rule is not followed:

**READ THE INSTRUCTIONS!**



**Figure 8 A rare sight, but essential for successful building (the manual that is, not Rob)!**

### **The Build Manual**

Reading the whole manual before starting is suggested. Reading ahead by at least the section being worked upon, as each section is reached, is recommended. Reading the instructions for the components under your spanners is essential! It is remarkable how often the instructions are over-looked or misread, remembering that you are going to fly in your finished aircraft!

Instructions, however, are never as good as they could be, and so corrections and suggestions for improving the instructions are welcome, preferably in writing by email. These can then be included in future updates of the manuals.

**If you have errata or receive updates to the manual, mark these immediately in your copy of the manual so that you do not forget them when you reach that stage.**

An electronic copy of the build manual is available online at [www.skyranger.co.uk](http://www.skyranger.co.uk), and any updates will be published there as soon as they are made.

Don't rush things, work carefully, and don't forget to enjoy building your aeroplane!

## **In case of difficulty**

If you cannot find a part, ensure that you have determined what it looks like, and that it is not already attached to a sub-assembly in the area you are working on. Often parts are hidden by the packaging, or lurking in the bottom of a box of bits in the corner of the garage, rather than being missing from the kit.

If you have a problem that you cannot resolve by a careful read of the instructions with the appropriate parts in front of you please have a look in the Skyranger internet discussion group, send an email, or if all else fails ring:

**01604 494459**

**Note that most enquiries can be answered by a careful read of the manual, so do give it some thought before calling.**

Email is preferred and more convenient than the telephone, as it makes it simple to communicate answers to other builders and allows time for a better more researched reply to your questions. Please use [paul@flylight.co.uk](mailto:paul@flylight.co.uk)



**Figure 9 We await your call on the Nynja Hotline! – but consider email please!**

## **Photographs**

The manual has lots of drawings and photographs to help you build your aeroplane. The photographs are chosen to illustrate each point, but often include other areas of the aeroplane in the background. However, due to the number of modifications made during the UK certification phase you should be cautious about assuming that background items are shown as they should be on UK specification aircraft. Many parts are common to the Skyranger and Skyranger Swift, and these may be shown in some of the photos and drawings where commonality exists.

## **1.2 The BMAA Homebuilt Aircraft System**

Before starting the build of your Nynja you must register the project with the BMAA. The required forms are downloadable from the BMAA website at [www.bmaa.org](http://www.bmaa.org), go to the Technical Information section, click on Forms, and download form BMAA/AW/022.

An example form for a Nynja fitted with a Rotax 912ULS and standard Kiev prop 283 is shown towards the end of this manual.

You will have to find a BMAA Inspector to oversee the project. A list of Inspectors is available from the BMAA if required. Fill in the form with information about your aircraft and Inspector.

Send this form, along with the certificate of conformance for the aircraft, engine and propeller, with the current fee to the BMAA.

The BMAA will then register the project and issue you with a project number. They will send you a pack of paperwork with information about building a BMAA homebuilt, and a stage inspection form to be completed during the build by yourself and your Inspector.

**Please read all the paperwork that the BMAA send you when you receive it – this may prevent stress later!**

You can also register the aircraft with the CAA and order registration letters (available from Flylight) to save time later.

Your Inspector is required to visit prior to commencing any real building to inspect your workshop and the kit. This forms the first stage inspection.

Your Inspector has to sign off several key stages of the build. Get his signature on the form at the time, just in case! He can be a very useful source of knowledge and advice, and should be your 'mentor' during the build. Also, a second pair of eyes and an experienced mind can often solve problems for you in an instant.

Inspectors will vary somewhat in their likes and dislikes, and so requirements may vary from what you may consider to be adequate. It is best to listen to your inspector's views, but in case of specific queries either you or your inspector may contact Flylight or the BMAA directly to discuss matters.

Please respect the stage inspections and do not present him with a fully built aircraft for the first visit! It is not his fault if you have to undo a lot of building to make right something that should have been checked in a stage inspection before continuing further. If there is a delay in having an inspection it is better to get on with building bits and pieces like wheels and wing frames than to continue adding to the main assemblies.

When your aircraft is complete and to your Inspector's satisfaction, the completed stage inspection form is sent to the BMAA. Also required to be sent at the same time is the Engine Installation Check Sheet (either the Rotax version or the generic BMAA version for non-Rotax engines). This details tests required to ensure correct installation and set up of the engine, such as the fuel-flow test described towards the end of this manual. Again your inspector has to witness the tests and sign the form.

The BMAA will then process the paperwork and raise a BMAA AW029 giving permission to test fly, along with a draft MAAN (Microlight Aircraft Approval Note) for

specific clearance and flight testing of your aircraft. This will require checking and returning to the BMAA for an authorisation signature to make it valid.

Initially your aircraft must be flown by a BMAA Test Pilot, or a specially authorised check pilot. He/She will fly the aircraft to the flight test schedule to ensure that your aircraft is set up and flying as it should. You can accompany them for the flight tests as observer / secretary. When the aircraft is flying satisfactorily (some trimming / adjustments may be required), then if you have suitable experience you may fly the aircraft. 5 hours of flying are required to prove reliability and debug the aircraft, before an application can be made for a full permit to fly. Whilst waiting for this to arrive you are normally permitted to fly the aircraft, continuing to obey the restrictions of the test flying clearance contained in the AW029.

If you are the first with a new engine or propeller type, or have made any major modifications to your aircraft, then 25 hours of reliability testing are usually required. If you plan any modifications then it is essential that the BMAA is informed at the beginning of the project, so that a technical investigation can be made and approval for you to go ahead can be given.

It is likely that you are keen to begin construction, and are waiting impatiently for the paperwork and your inspector to allow you to do so. However, this short delay can be used very productively to familiarise yourself with the instructions and the components, and prepare them for use.

## **Modifications**

You may desire to install equipment such as a radio, strobes etc.. These will constitute modifications to the standard aircraft and therefore must be done in accordance with BMAA procedures. Details of the most common modifications are included in the TIL's, and Standard Minor Mods (SMM) available on the BMAA website ( [www.bmaa.org](http://www.bmaa.org) ) . If these are done at the time of construction no additional modification fees are payable.

For modifications not covered by the TIL's, or SMM's, it is probably better to complete the standard aircraft and commence flying before proceeding with the modification. This is because non-standard modifications will introduce complexity and delays into getting you aircraft flying, and so these are best done at leisure when you already have your aircraft in the air.

Note that the Nynja succeeds in providing a capable aeroplane at an excellent price by following the principle of simplicity. Some areas may look basic at first glance, but meet the stringent requirements of BCAR Section S without adding cost and weight. Any modifications you make must also meet Section S, but it is up to you how much cost you are willing to bear and where you spend your weight. However, increased cost and less fuel carrying capacity are difficult to avoid.

**Do not begin any modifications without first speaking to your inspector, the BMAA, or Flylight Airsports.**

### **1.3 General Assembly Notes**

Before starting to assemble anything, read the whole of this manual to get an overall impression of the order and methods of assembly. The sequence of construction is the one used to build the importer's aircraft, and should be adhered to. If you wish to change the sequence, you may find difficulty in fitting other parts later, so read ahead carefully to determine the effects of your changes. Flylight Airsports cannot advise on, nor be responsible for, the consequences of not following the instructions, as if we have not tried something we cannot comment upon it with any experience.

#### **Unpacking**

To familiarise yourself with the kit components it is useful to unpack the kit and sort it into groups for each assembly stage, such as wing parts, fuselage parts, undercarriage etc.. Do this in conjunction with the packing list and the instruction manual to determine that you have all the required parts.

**If you cannot find a part, check under the packaging on related assemblies, and make sure you know what it is that you are looking for, as parts may be rolled up or transported inside other parts.** For instance smaller tubes may be slid inside larger ones.

Don't forget to check **all** the boxes, in case you've put a box aside somewhere. Some small parts may be hidden within packaging foam 'snow' in the bottom of boxes, so don't throw any boxes or packaging away until you have ascertained for certain that you have all the parts – we have stories of unloading skips to retrieve parts that have gone with the rubbish!

We also pack some parts in the engine box – so remember to look in there.

This may all sound obvious, but we know from past experience that even big parts like propellers can be thought missing when they are there all the time!

**Don't try and remove the glassfibre parts from the big wood box without first removing at least one of the metal side rails on the box – or the gap will be too small and you will flex and crack the big side panels!**

#### **Initial assembly with non locking nuts**

During initial assembly it may be helpful to use wing nuts or normal nuts (wing nuts are preferred as they are more obvious and less likely to be forgotten!) rather than Nyloc nuts for test fitting pieces, or on pieces which need to be removed later to fit the coverings or other parts. Alternatively, only tighten the Nyloc nuts up to the Nyloc section until ready to apply threadlock and tighten properly.

#### **Assembly**

If in doubt about a part, or an assembly, read ahead and pay particular attention to drawings and photographs. Note that the direction of bolts (up/down, pointing forwards/backwards) may differ between drawings and photographs. Normally, the bolts will be inserted from the top or the front, unless other considerations apply, such as coverings or access.

Remember to replace any non locking nuts with Nyloc nuts before final assembly, and also:

**REMEMBER TO USE LOCTITE 243 ON ALL NUTS.**

This is usually available from your local fastenings company, look them up in the Yellow Pages under “Fixings and Fasteners”, and you will never be stuck for nuts and bolts again!

Loctite should be used very sparingly. A common mistake is to overuse it. Loctite smeared over the outside of fasteners acts as a corrosive agent. Any surplus should be immediately removed with a soft cloth.

A good tip is to paint a red stripe across the nut and bolt end after final tightening. This way it will be easy to inspect and spot any nuts not finally tightened.

### **Main tools needed for assembly**

Spanners and sockets in the range of: 6, 8, 10, 12, 13, 14, 17mm

Allen keys: 4, 6, 8mm

Metal saw

Drill and bits for metal

Rivet pliers

Cutting pliers

General pliers

Screwdrivers, flat and cross-head

Hammers, metal and rubber/plastic

Mouse tail file with diameter less than 6mm

Flat file

Engineers Rule

Tape measure

6mm reamer (desirable)

Wire-locking pliers (desirable)

Cleco's or Skin pins for 4mm holes

Dremel Multi tool or equivalent small cutting / sanding tool

Soft faced clamps

Rivnut installation tool and 4 and 5mm Rivnuts (these can be really useful to make a tidier alternative to nuts or captive nuts on things like instrument panel fixings)

### **Products needed for assembly**

Loctite 243, to be used on all bolts

Silicon grease

Oil for general use

Oil for engine and gearbox, see engine documents

Epoxy adhesive (Araldite or similar)

Lock-wire

### **Holes**

All the holes have been drilled to a high accuracy, however it may sometimes be necessary to use a round file or reamer to ease the insertion of some bolts. Be careful not to make a hole too large however, sometimes all that is required is to loosen other bolts nearby, or to apply pressure to some other part. Generally bolts should not be tightened up until all the parts in a particular sub-assembly are assembled, to avoid the common problem of the final bolt not fitting!

## Washers

Metal washers should be used to prevent scratching of the surface as a nut is tightened.

Nylon washers, or similar plastic washers, should be used to:

- a) fill spaces between parts, such as between tubes and U-brackets
- b) avoid friction between two moving metal parts, such as the stick and its supporting bracket
- c) avoid contact between parts of different materials, especially stainless-steel and aluminium

The final point above is primarily to prevent the hard steel wearing through the soft aluminium due to vibration, rather than for electrolytic reasons, as the bolt passing through both materials will still complete the electrical connection.

## Saddle washers

Normally they are shown on the drawings and photos.

Generally they are used between two crossed tubes or between a tube and a flat bracket.

Take care not to overtighten bolts which pass through plastic saddle washers as you may cause them to split.

## Nuts and washers

Standard nuts and washers in the main kit are metric zinc plated steel. An acceptable alternative is to use A2 stainless nuts and washers. These can be purchased from a fastener supplier for relatively low cost and provide protection from corrosion. Note that bolts supplied are a mix of 8.8, 10.9 and 12.9 and Eastern European Mil spec and some smaller bolts are stainless steel. These may NOT be changed for other specification or to stainless steel as strength, malleability and dissimilar metal corrosion can be problems.

## Bolts

Generally all bolts should bear on their unthreaded lengths, not on the threaded portions.

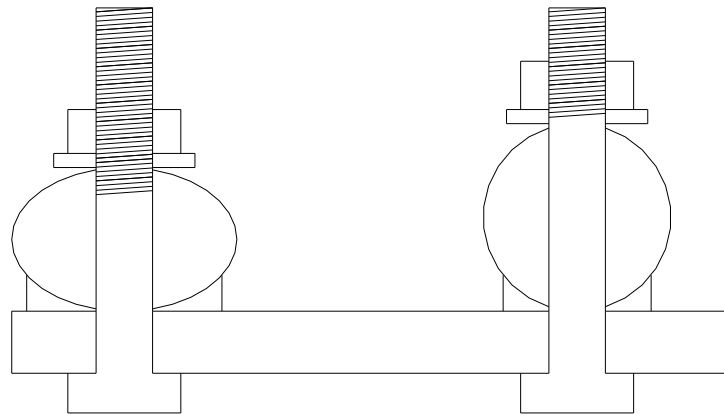
It is also important that nuts are not screwed on so far as to become 'threadbound' by reaching the limit of the threaded portion. You can use an extra washer or two to adjust the effective length and prevent this where required.

Turn nuts, not bolts whenever possible, when tightening, as this may damage the plating and encourage corrosion. Washers are only needed under nuts to allow them to be turned, whereas bolt heads should not be turned.

Do not over-tighten bolts, avoid deformation of tubes or brackets.



**IMPORTANT: tubes must not be visibly deformed.**



**Figure 10 Left - WRONG – squashed tube, thread in tube. Right – RIGHT – tube still round, thread stops in washer(s).**

Every wing nut has to be fastened by a security ring or aviation ‘nappy pin’.

Nyloc nuts should be used only once.

When cutting bolts short, a minimum of two threads should protrude from the nut.

Paint the cut end to prevent rusting.

Bolts subject to rotation should be drilled and locked with a split pin. Examples include stick pivot bolt, torque-tube pivot bolt, rudder link bolts.

### **Wire-locking**

Certain parts require securing with lock-wire, such as engine bolts and turnbuckles. If you have not done this before, discuss how to do it with your inspector. A basic guide to wire-locking bolts and turnbuckles is included at the end of this manual.

### **Stainless-steel parts**

A number of tubes have flattened steel end-fittings which may require slight “tweaks” to align them as required. This should be done carefully in a vice, with wooden jaw pieces to protect the surfaces.

**Avoid bending the parts back and forth repeatedly, and avoid bending them at the hole position.**

The finish on the stainless-steel parts is quite varied. If desired these parts can be polished to a shiny finish, although those positioned in the pilot’s line of sight may be covered in anti-reflection black coatings or plastic sleeving if desired. Scotchbrite pads can be used to provide a pleasing, even, cosmetic finish.

### **Coverings**

Handle the coverings with care, pay attention to the risk of bolt heads, corners and reinforcements/stiffeners damaging the covering as it is put on.

Dacron coverings need care to avoid getting dirty and becoming stained. Keep your hands and tools clean and oil-free when working with or near these coverings.

You can remove most dirty marks on Dacron with a sponge soaked with tepid water and a mild detergent, followed by rinsing using only tepid water.

## **Part numbering**

Numbers in bold italics refer to a part number, either as shown on the relevant drawing or a universal part number with a prefix. Prefixes refer to the following:

<b><i>tu</i></b>	tube
<b><i>tual</i></b>	aluminium tube
<b><i>tuac</i></b>	steel (acier in French) tube
<b><i>u</i></b>	U-bracket
<b><i>ual</i></b>	aluminium U-bracket
<b><i>me</i></b>	metal plate piece
<b><i>meal</i></b>	aluminium metal plate piece
<b><i>meac</i></b>	steel (acier) metal plate piece
<b><i>ca</i></b>	cable, wire rope

The material-type part of the number is not always used.

During assembly follow the drawings and photographs corresponding to the text.

## **Drilling and cutting**

When drilling holes or cutting parts be very careful to measure and mark the correct positions. Check these a second time before proceeding to cut or drill.

**The old adage of measure twice, cut once still applies!**

**Otherwise, you won't be the first to ring up to order a new bit, having chopped something too short!**

If you find a part which you think is wrong, in terms of size etc., be very sure that this is so before cutting or drilling etc. to correct the problem. For instance, over-long bolts may have extra parts to be fitted later. Leave irreversible actions until the end of the build!

When drilling holes in metal, use a centre punch to prevent the drill wandering, and start with a small pilot drill working up to the required hole size.

It can be useful to use masking tape on fibreglass gel surfaces to help prevent cracking, and to reduce the risk of marking the surface if the drill should slip.

### **1.4 Finish**

All Aluminium parts are supplied anodised or powder coated. Do not be alarmed if some marks are present in the finish of the tubular parts, this is a result of the suspension method at the anodising plant. You may also notice areas on tubing that may appear to have fine sanding marks. This is done prior to the anodising process to polish out any small scratches. It is also not unusual to find small areas of silver paint applied at the final stage over any small remaining marks prior to leaving the factory. Some light scuff marks may be present as a result of storage and transit.

This is normal. Deep scratches or dents are not acceptable – ask you inspector for advice, and refer the problem to the importer.

Aluminium plate parts may be painted to improve their cosmetic appearance if desired. Use a Scotchbrite pad or lightly sand with fine wet and dry before using a suitable aluminium primer and top coat. Ensure that all painting operations result in a thin covering that will not hide defects from inspection.

Steel components are all supplied plated and / or powder coated, for corrosion resistance. Again they may be painted for extra protection or cosmetic reasons if desired.

Further protection from corrosion can be beneficial for longevity, and to resist the ravages of operation near the sea or storage in damp hangars. Aluminium and steel parts can be treated with corrosion protection products such as the excellent ACF50. This should be squirted in all tube ends and around fittings and applied to the outside with a soft cloth. An initial thorough application before covering is recommended (don't do this if you have Dacron covers that you intend to paint), followed by periodic repeat application.

'Wax oil' or similar propriety products may also be used inside tubes and around fittings.

Glassfibre fairing parts are supplied in a white finish. This can be polished with T cut or similar to a high sheen. Alternatively they can be painted, but avoid using dark colours on the rear fuselage fairings as strong sun can generate high temperatures that will soften the glass fibre. None of the fairings carry structural loads so this does not have any safety implications, but this may result in cosmetic damage in the form of permanent distortion / waves in the fairings.

Self adhesive vinyl graphics may be applied, but again avoid large areas of dark colour.

Dacron coverings may be lacquered with a special process using Automotive Polyester or Acrylic Lacquer mixed with a flex agent. Refer to the importer for more information. Advantages are stronger colours and a sealed shiny finish which allows oil etc to be wiped off without leaving marks. Disadvantages include extra weight and the loss of the ability for the coverings to be re-used in the event of removal for damage repair.

Xlam coverings can be decorated with Vinyl graphics. Take care to degrease the surfaces prior to application and use good quality Vinyl with good adhesive properties. Application in low temperatures is to be avoided, and some work with a heat gun and application of pressure will be required to work the Vinyl into the weave and stitching to ensure good long term adhesion. Seek specific advice before application.

## 1.5 Weight

The UK prototype Nynja with Xlam coverings, Rotax 912ULS and standard 'console' dash, basic analogue instrument fit, installed intercom box, aerial and radio, and including doors (see note below\*\*\*), has been found to have a basic empty reference weight of approximately 258kg. Options such as, wheel spats, spinner, thick carpet, etc will have a weight penalty. Painting metal parts, cowlings and applying lacquer to Dacron coverings will have a weight penalty. Additional avionics or strobes are also surprisingly heavy.

It may be necessary to make choices in these options to ensure that the weight remains inside the maximum permitted Zero Fuel weight (ZFW) for the aircraft. The ZFW will vary according to the fuel burn of the chosen engine option. Max ZFW for the 912ULS engine Nynja is 268Kg

Refer to the Homebuilt Aircraft Data Sheet (HADS) or the BMAA for further information on the rules regarding weight for this class of aircraft.

Below is an approximate guide to the weight of specific options:

Wheel spat kit	+ 4.0Kg
Nynja wingtip fairings	+ 2.0Kg
Skyranger wing tip fairings (alternative to above)	+1.5Kg
Carb heat (912 engines)	+0.7Kg
Heater option	+ 1.0Kg
Spinner	+0.5Kg
912UL engine	- 1.5Kg
Slipper Clutch on 912/912ULS gearbox	+1.5Kg
Large starter motor on 912 / 912ULS	+0.5Kg

\*\*\*\*Items that are non essential for flight and are easily removable may be eligible for non inclusion in the ZFW calculation and be considered as payload. These items may include:

Baggage hammock	1.5Kg
Doors	5.5Kg

Other items may be eligible – See latest version Of HADS or refer to BMAA.

If a total aircraft parachute recovery system is fitted, then the max permitted MTOW rises to 472.5Kg and Max ZFW also rises 22.5Kg to 290.5Kg. These systems can typically be installed for around 12 - 15kg, allowing the remainder of the allowance to be used for payload, or additional fixed items.

Weight is surprisingly cumulative and dividends will be gained by 'thinking light' during every stage of the build. The benefits of an aircraft kept well under the maximum permitted weight will be better performance and payload capacity.

## 2. Forward Fuselage

**Note:** During assembly of the fuselage, hand tighten the bolts only as far as the Nyloc section. After the fuselage is complete and you are sure it is correct, you can go back and tighten all of the nuts.

If you wish plain nuts, or even better wing nuts, can be used in the initial construction, to be replaced with Nylocs when the time comes to tighten the nuts up. However, note that it is often beneficial to have the nuts loose anyway, to ease any alignment difficulties.

### 2.1 Tube Numbering

Refer to these drawings for tube numbers throughout the forward fuselage assembly sequence.

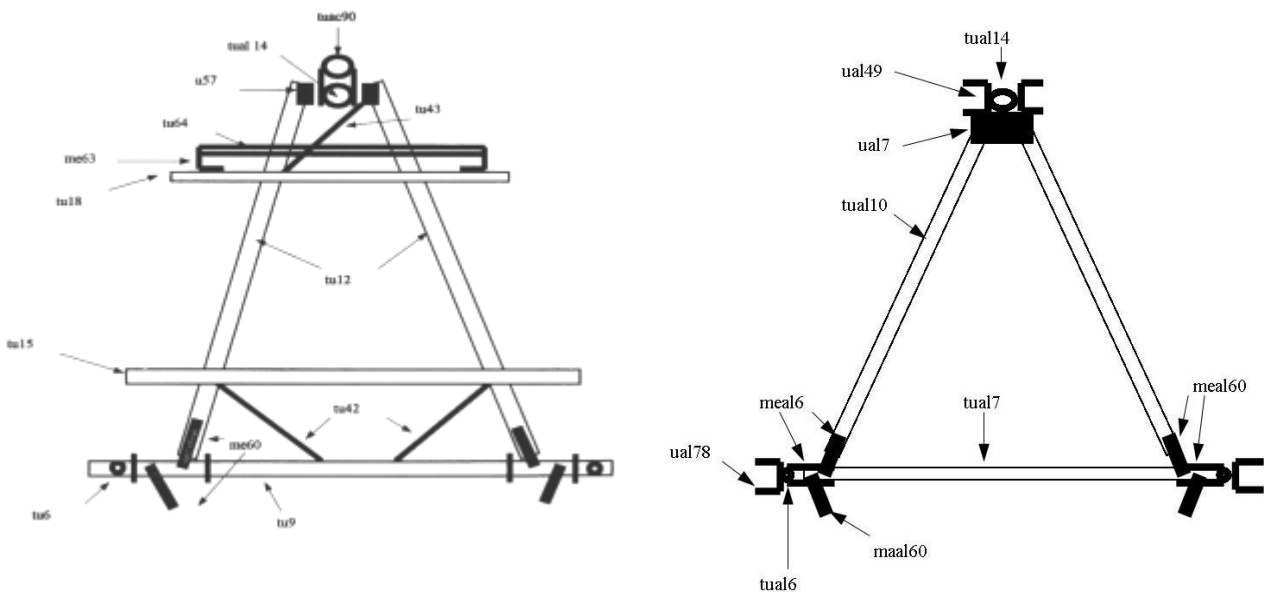


Figure 11 cabin lower and upper triangle tube numbering.

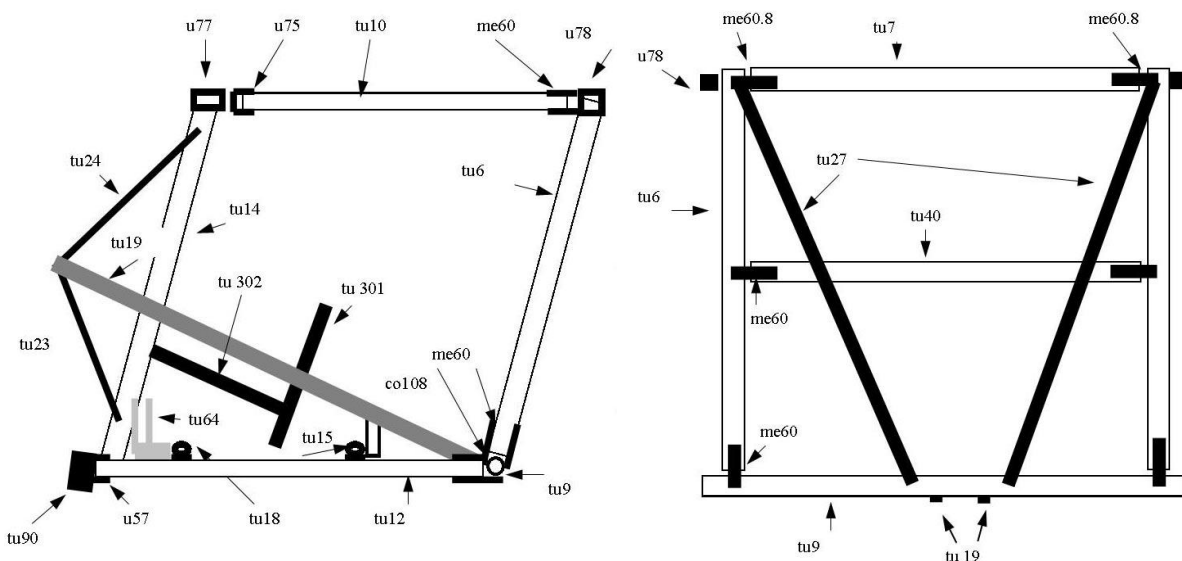


Figure 12 cabin viewed from port side, and rear cabin frame viewed from rear.

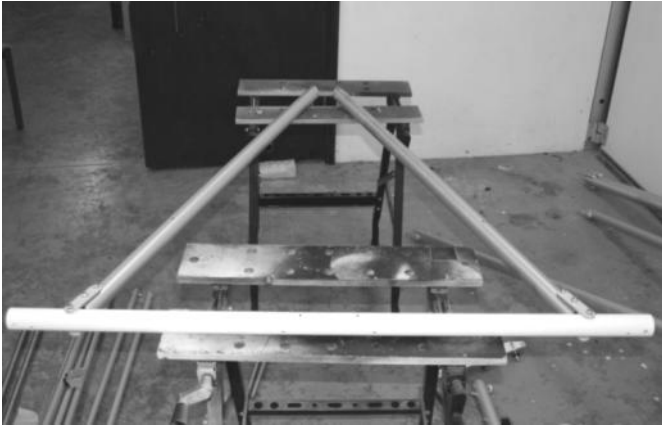


**Figure 13 forward fuselage from front quarter.**

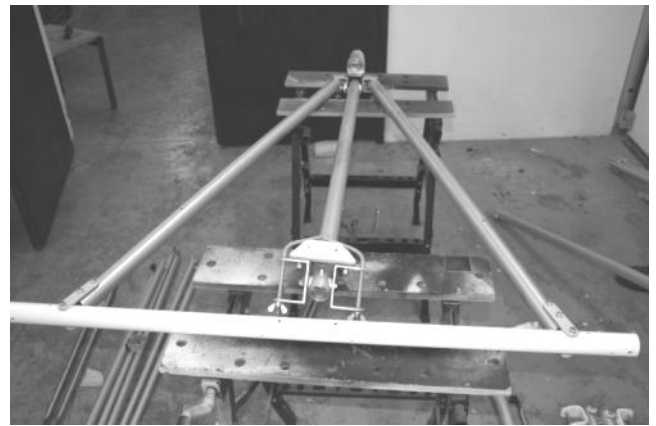


**Figure 14 Cabin upper rear corner**

## 2.2 Fuselage frame assembly overview



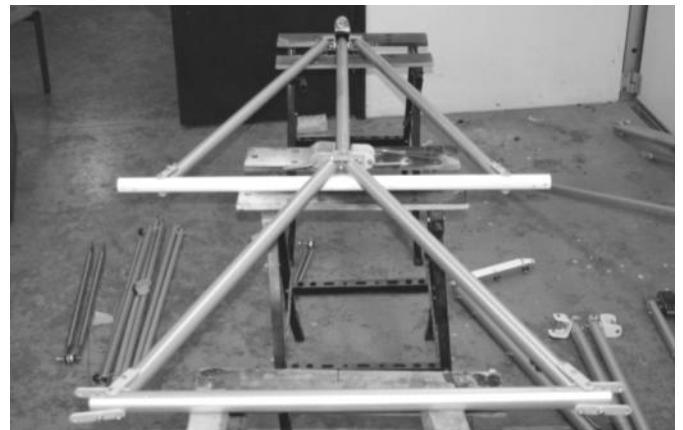
Lower triangle assembly



Attaching TU14



Upper triangle assembly



Attaching upper triangle to TU14



Attaching rear cabin uprights TU6



Attaching Upper triangle to uprights



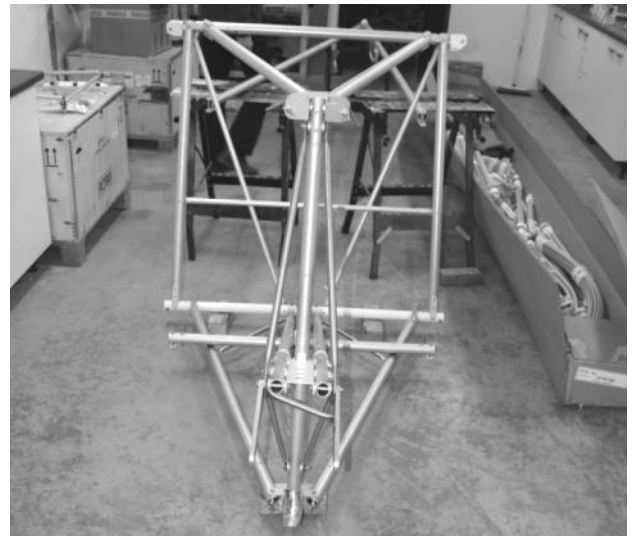
**Cabin diagonals TU27 attached**



**Twin TU19 tubes in position**



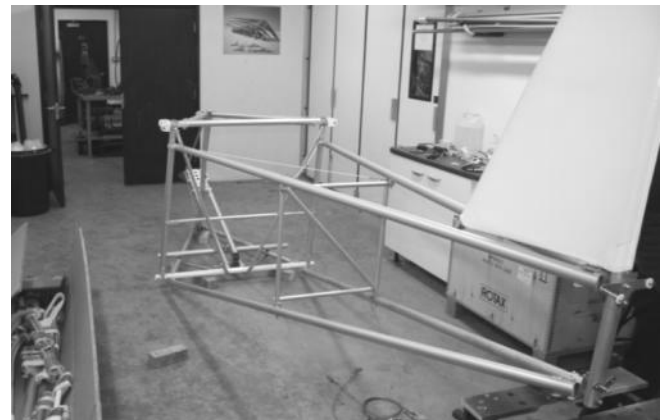
**Front seat support TU15 and braces**



**Forward engine mount assembly fitted**



**Assembling tailcone**



**Tailcone fitted to cabin**

**Figures 15 – assembly overview**



## 2.3 Lower Cabin Triangle

### 2.3.1 Orienting the main undercarriage cross-beam **tu9**.

The main undercarriage cross-beam **tu9** is made of steel.

Flip the beam over until satisfied that the holes are in the correct positions.

*The holes in the steel main undercarriage cross-beam **tu9** are drilled at an angle through the beam so that the tail section of the fuselage, which attaches to the third set of holes in from the ends, tilts upwards from the beam whilst the lift-strut attachment bolts, nearest the ends, remain horizontal.*



Figure 16 Tu9 (The big white tube), looking from above, front of aircraft to left

### 2.3.2 Fitting the sides of the lower cabin triangle to the main undercarriage cross-beam.

- a) Assemble the aluminium linking plates **9** onto the pair of lower cabin triangle tubes **tu12**, including the seat support brackets (Figure17)

*The linking plates are drilled with three 6mm holes, not at equal intervals. The centre hole is offset away from the single mounting hole. Remember the anti-crush spacers on the bolts (inside the tubes).*

The middle bolts have the seat support bracket, an L-shaped piece, on their upper ends, with the upstanding part of the bracket in front of the bolt. A piece of fuel tube may be slit to fit over the support, and secured with silicone sealant, to make a better rest for the seat base later.

*The bolts should pass from bottom to top (contrary to the drawing, but as per the photographs), to clear the undercarriage legs later.*

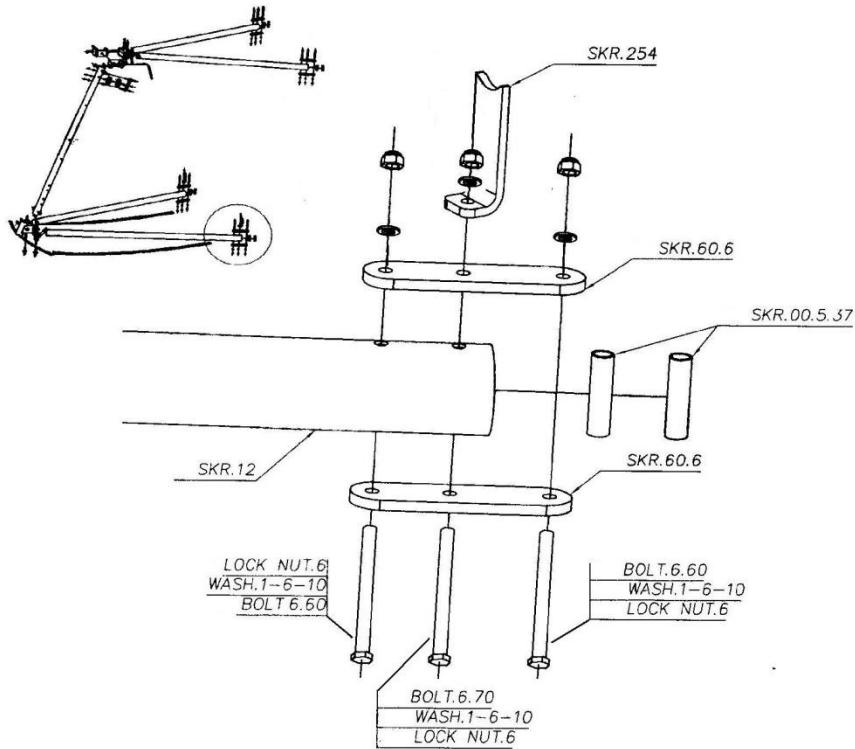


Figure 17 lower cabin triangle, rear of tube **SKR.12** (note, find **SKR254** in assembly bag A9)

- b) Assemble the pair of lower cabin triangle tubes **SKR.12** to the main undercarriage cross-beam **SKR.9** using the fourth set of holes inwards from the ends of **SKR.9**.

*The front ends of the lower cabin triangle tubes **SKR.12** should have the cut-outs on the inside, visible in Figure 19.*

*Bolt spacers are not needed in the steel undercarriage tube.*

*The bolts should pass upwards, to clear the undercarriage legs later.*



Figure 18 SKR.12 – 9 liaison

### 2.3.3 Fitting the front vertical to the lower cabin triangle.



Figure 19 and 20 forward ends of the lower cabin triangle viewed from below and above.

- a) Fix the lower guide **SKR90** for the nose-leg to the lower part of the front vertical **tu14**, between the two U-brackets **SKR76**.

*Note these U-brackets are slightly different from those used elsewhere in the kit, with the holes on the side parts further from the end (16mm from the end to the hole centre).*

*The front vertical **tu14** has a row of three 6mm holes at its upper end (amongst others), and a row of three 8mm holes at the lower end.*

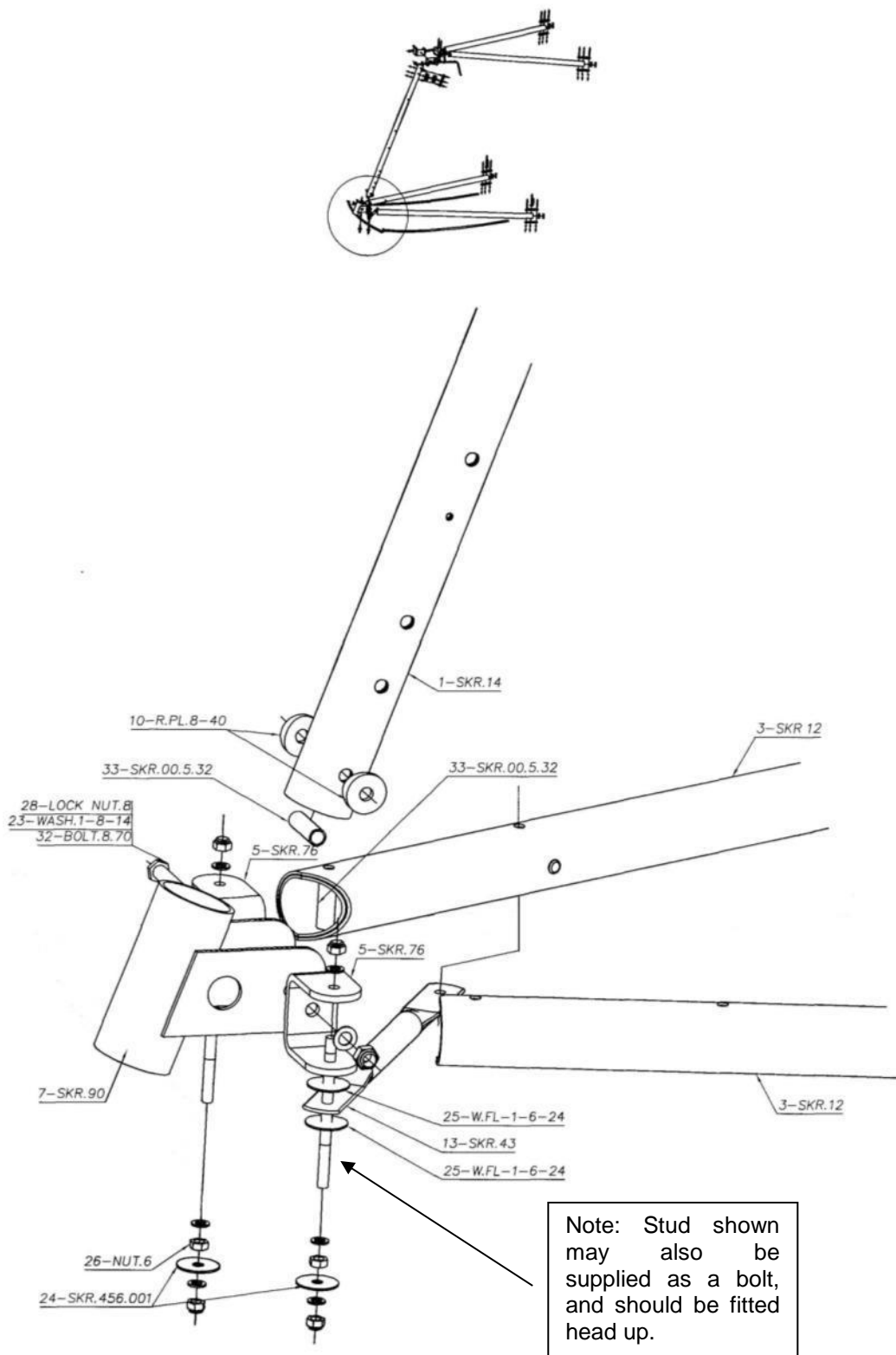


Figure 21 forward end of lower cabin triangle.

- b) Apply threadlock to the bolt securing guide **SKR90** to the front vertical **tu14** and tighten firmly, but take care not to distort or crush the tube.

*This should be done at this stage as the bolt holding this bracket is not easily accessible later.*

*Whilst the spacer should prevent crushing of the tube, it is better not to rely on it. It is permissible for the spacer to remain slightly loose, as under load it will still prevent excessive deformation of the tube.*

**Do not distort the tube.**

- c) Mount the U-brackets **SKR76** to the lower cabin triangle tubes **SKR12**

*Note the use of a spacer sleeve in the tubes.*

*The studs should be long end downwards to mount the bottom of the firewall and the front of the fuselage covering later. Discard the curved metal washer if fitted – as this is a Skyranger part not used for the Nynja.*

*If the bolt thread sticking out of the nut securing the U brackets to the TU14 fouls the TU12 end file the end of the TU12 to provide clearance*

- d) Mount the steel diagonal-brace **SKR43** to the bottom of the stud through the port tube. Use thin plastic washers **W.FL-1-6-24** and steel washers **SKR456.001**

*The other end of the brace will be attached to the rudder pedal mounts later. The brace may be supplied attached to the mounts, have a look under the packaging.*

*Thin plastic washers may be used to take up any slack between the tubes and U-brackets.*

## 2.4 Upper Cabin Triangle

### 2.4.1 Fitting the sides of the upper cabin triangle to the upper rear cabin cross-piece.

Refer to Figure 23 and 24.

- a) Fix the aluminium linking-plates **SKR60** on the upper rear cabin cross-piece tube **tu7**, which links the trailing-edges of the wing.

*These linking plates are drilled at one end with an 8mm hole and at the other with two 6mm holes.*

*The row of small holes should point forwards, whilst the bolts point rearwards.*

*The bolts will be tilted down and backwards compared to the vertical bolt holes for the cabin upper triangle and tail cone tubes, as the rear cabin frame is raked backwards.*



Figure 22 Port end of the upper rear cabin cross-piece.

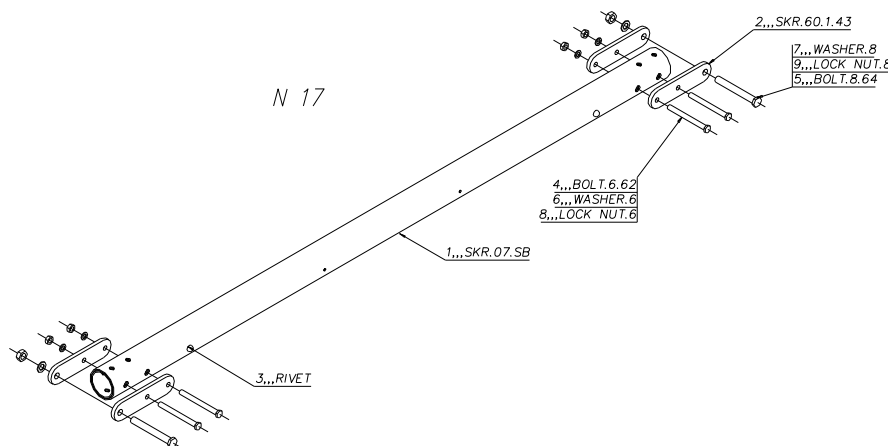


Figure 23 upper rear cabin cross-piece.

- b) Assemble the upper cabin triangle tubes **tu10** with aluminium linking-plates to the upper rear cabin cross-piece **tu7**.

*The drawing shows the lower cabin triangle tubes **tu12**, however the fittings are the same on the upper cabin triangle tubes **tu10**. Note that the tubes themselves are not the same.*

*The cut-outs at the front of the upper cabin triangle tubes **tu10** should face outwards.*

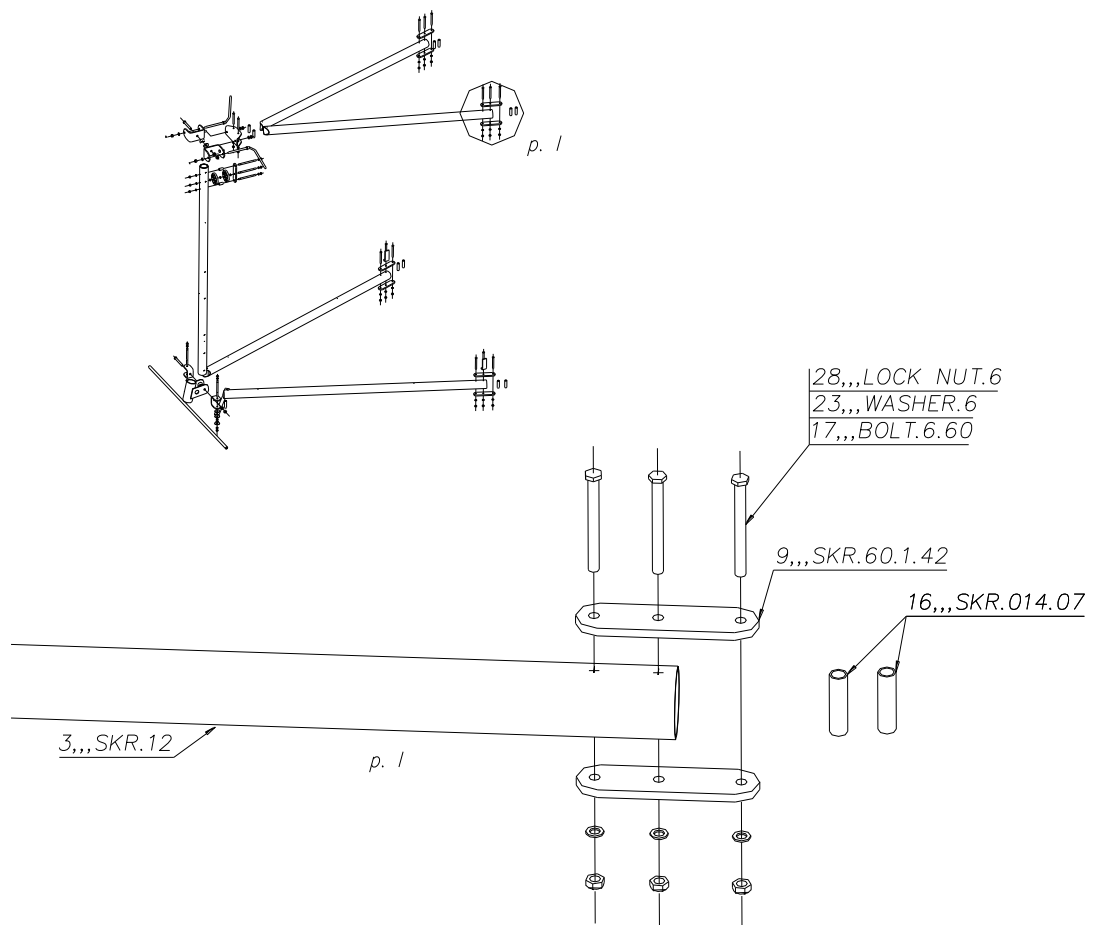


Figure 24 rear of upper cabin triangle tube tu10.

#### 2.4.2 Assembling the top of the front vertical tube.

- Fix the U-bracket **SKR75** and the pair of U-brackets **SKR78** for the leading-edges on the front vertical tube **SKR14**.
- Mount the aileron cable pulleys.
- Assemble the two upper cabin triangle tubes **SKR10**, linking them to the double U-bracket **SKR75**.



Figure 25 forward end of upper cabin triangle.

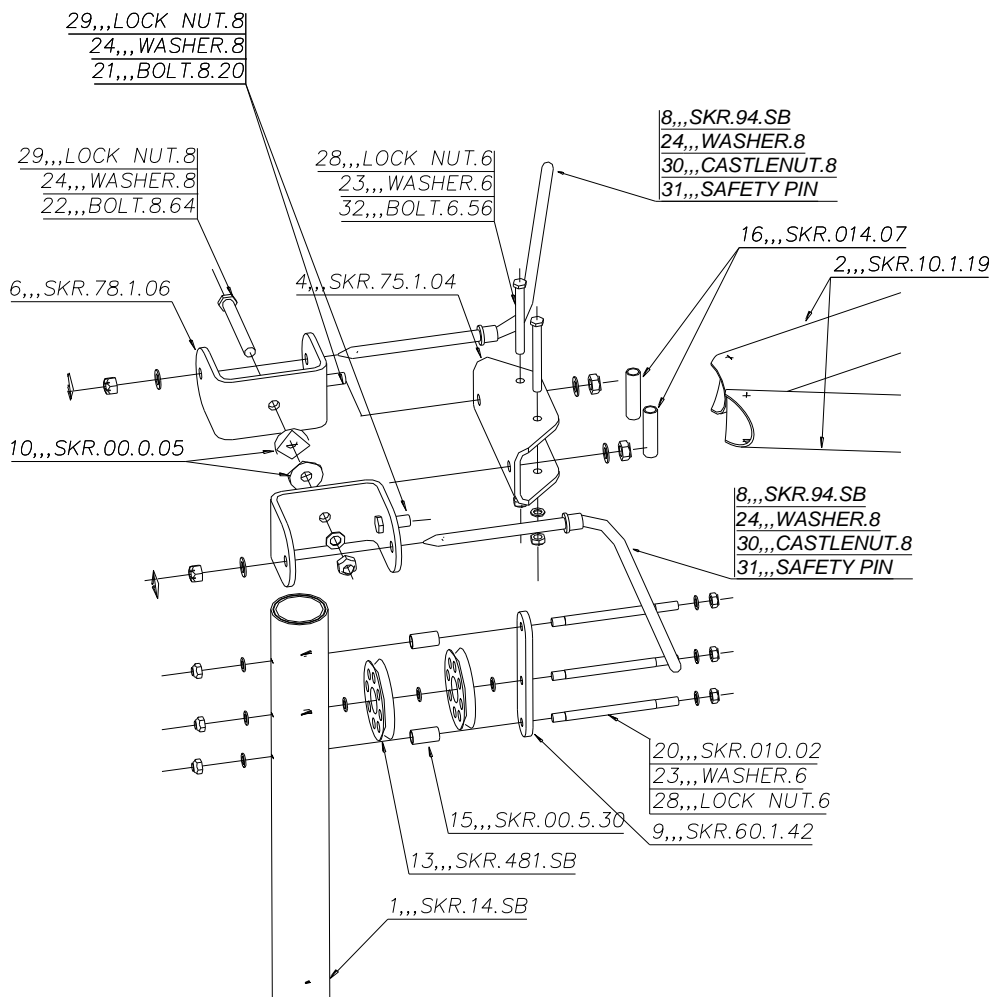


Figure 26 forward end of upper cabin triangle.



## 2.5 Rear Cabin Frame

### 2.5.1 Preparing the rear cabin uprights.

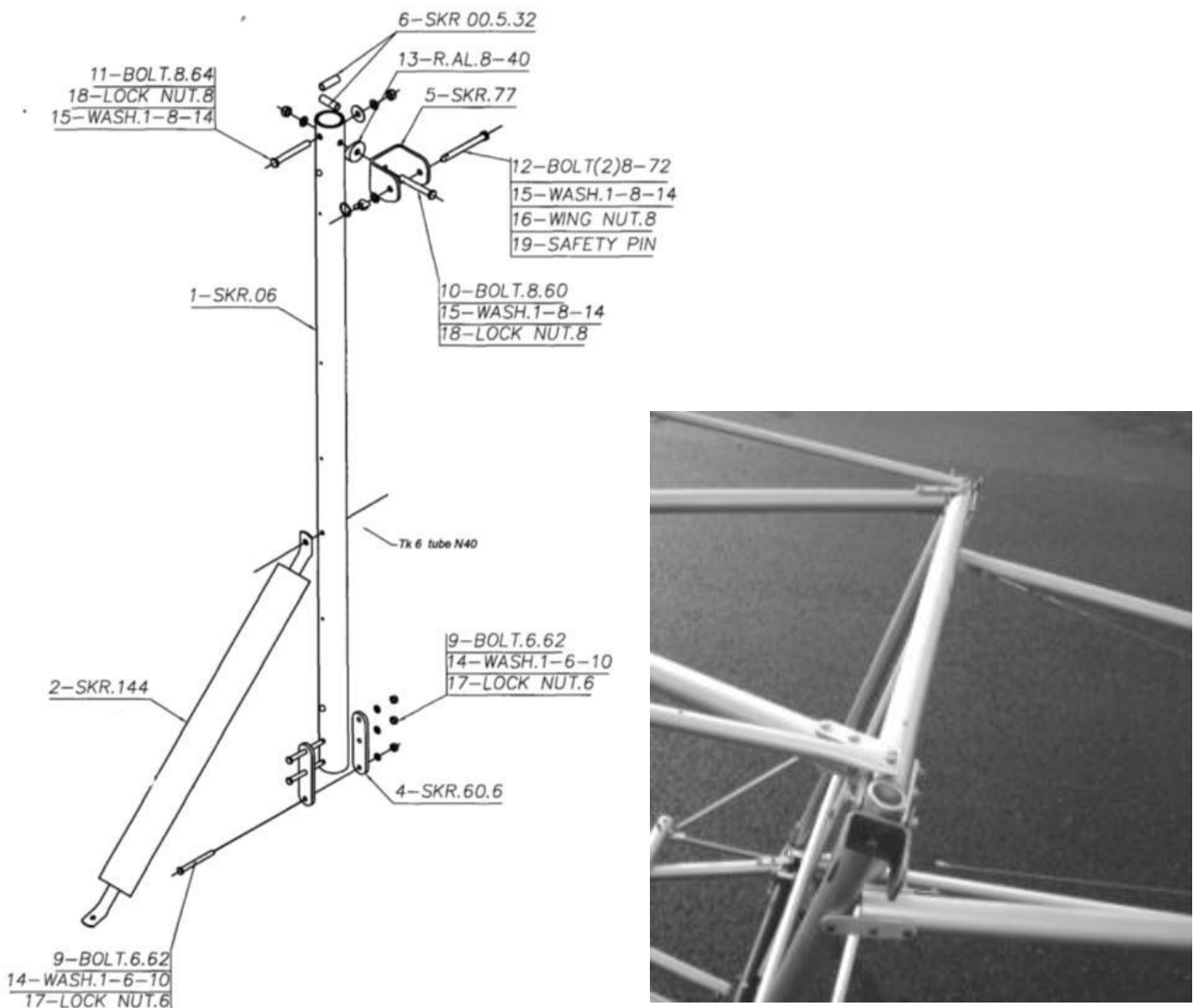


Figure 27 rear cabin uprights and correct handing for attachment of SKR2 fuselage longerons

- a) Fix the steel U-brackets for the trailing-edges with the taper downwards, using an aluminium saddle washer under each, against the rear cabin uprights **SKR6**.

*The rear cabin uprights **SKR6** have inner sleeves at their upper end, and are handed in that the holes that connect the upper rear fuselage longerons TU2 should be angled for the tailcone taper.*

*The nuts may foul the upper rear cabin cross-piece **SKR7**, in this case file away a little from the TU7 to provide clearance.*

*A spacer should be used on the bolt inside the tube.*

- b) Apply threadlock and tighten the bolts holding the trailing edge U-brackets, as they are not easily accessible later, but not so tight as to prevent easy rotation of the fittings by hand pressure.

## 2.5.2 Fitting the rear cabin uprights.

Refer to figure 27

- a) Assemble the rear cabin uprights **SKR6** to the main undercarriage cross-beam **SKR9**, using the second set of holes from the end.

*Remember the bolt spacers on the two bolts at the bottom of **SKR6**.*

*The bolts should all point rearwards through the main undercarriage cross-beam **SKR6**.*

- b) Lift the upper triangle into position on the rear cabin uprights **SKR6** and temporarily secure with an 8mm diameter bolt.

- c) Secure the bolts through the rear cabin uprights **SKR6** and the upper cabin triangle tubes **SKR10** including the proper spacers etc..

*This is easier now the upper cabin triangle is in place, although it is still worth leaving all the accessible bolts loose until more of the fuselage is assembled.*

*The 8mm bolts securing the rear cabin uprights **SKR6** are fitted with spacers and the nut must not be done up yet as there are more pieces to fit to it.*

## 2.6 Rear cabin frame bracing.

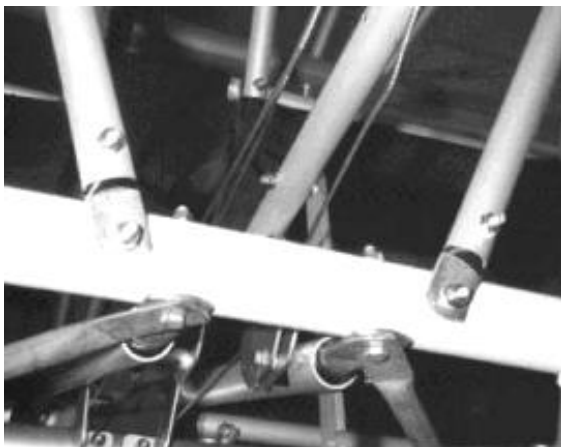


Figure 28 lower and upper ends of rear cabin frame diagonals.

- a) Bolts and fittings for the SKR9 tube are packaged separately – in a bag marked '9', Find these now.
- b) Assemble the steel end pieces into the rear cabin frame diagonals **SKR27**.

*The one with the 8mm hole goes at the upper end and the one with the 6mm hole goes at the lower end.*

- c) Install the bolt and spacer to support the seat a short distance above the lower ends of the rear cabin frame diagonals **SKR27**, Figure 29

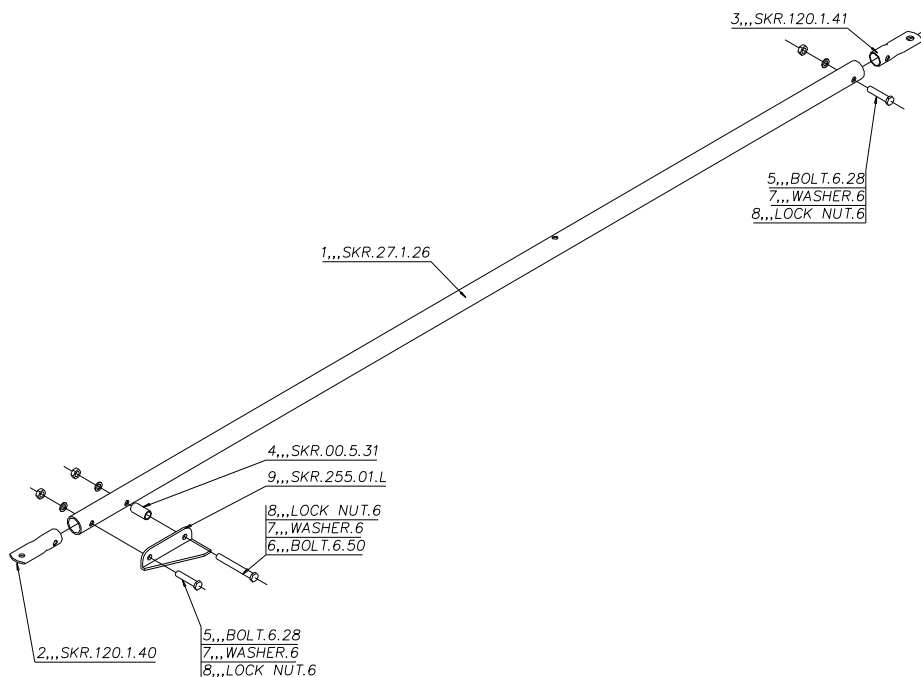
*These should be oriented with the supporting part towards the middle of the aircraft. Note that the spacer tube is also shown on Figure 30 as well as the small bracket piece. The Nynja should be supplied with round peg support as per picture below.*



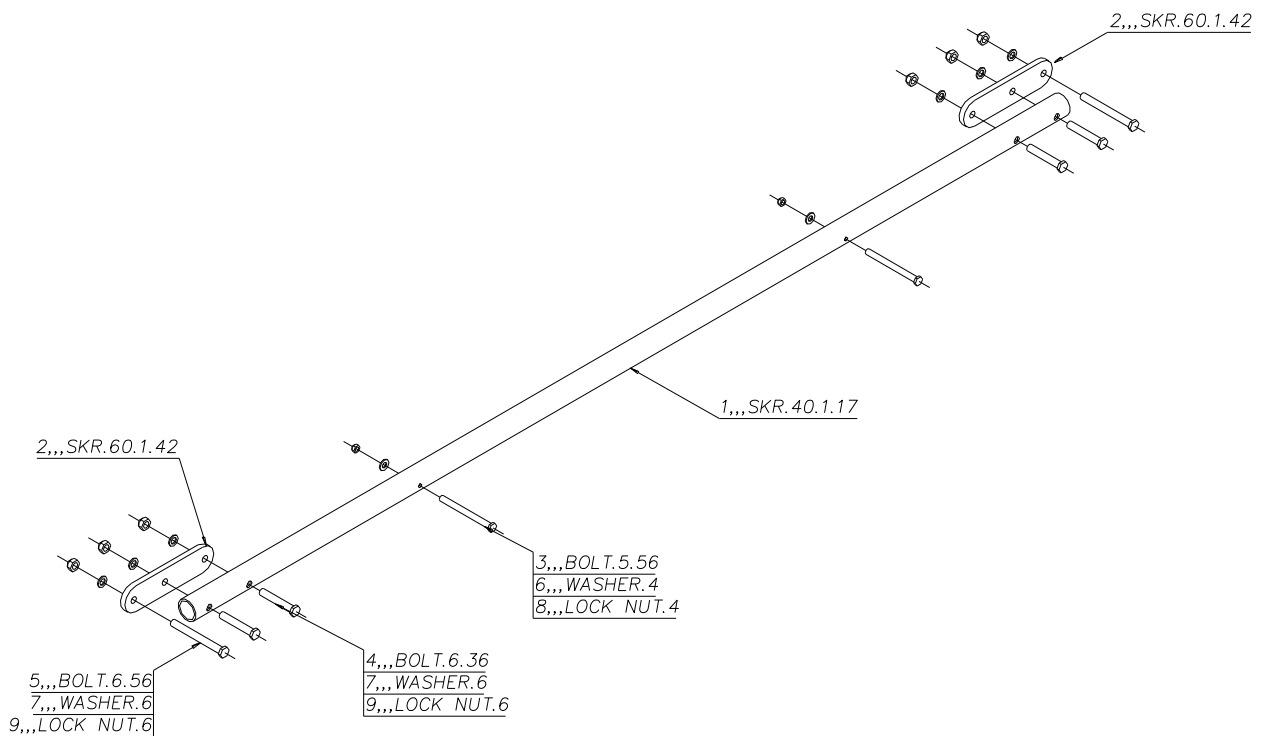
**Figure 29 seat support peg.**

- d) Stiffen the cabin back with the two rear cabin frame diagonals **SKR27**.

*These are positioned behind the rear cabin uprights **SKR6**, with the seat supports pointing inwards and upwards, and their supporting part towards the front.*



**Figure 30 rear cabin frame diagonal, port side viewed from rear.**



**Figure 31, tu40, rear cabin frame cross-piece, looking from the front.**

- e) Fit the upper ends to the end of the 8mm bolts at the top of the rear cabin uprights **SKR6**.

*The upper end of the round tube part of **SKR27** will touch the rear cabin uprights **SKR6**. If interference appears great, it is permissible to flatten or file the upper ends of the **SKR27** to ease this. A steel washer may be placed under the steel end piece on the rear cabin frame diagonals **SKR27**, to further help, but don't be concerned at some interference.*

Attach the lower ends to the rear of the main undercarriage cross-beam **SKR9**.

*The final attachment be quite tight to get on and an additional person or a ratchet strap may be necessary to provide tension to the frame to help.*

Assemble the rear cabin frame cross-tube **SKR40** and attach to the rear of the rear cabin uprights **SKR6**, but in front of the rear cabin frame diagonals **SKR27**.

*The bolts should point rearwards, and pass through the upper ends of the stainless braces **SKR144** before the rear cabin uprights **SKR6** and finally the attachment plate on the rear cabin frame cross-tube **SKR40**.*

*Include a thin plastic washer between the brace and the aluminium rear cabin uprights.*

## 2.6.1 Fuel tank upper mounting pieces.

Refer to Figure 32

- a) Where the rear cabin frame cross-tube **SKR40** crosses the rear cabin frame diagonals **SKR27** they should be connected with a bolt, pointing backwards.

*UK MOD – the holes will need drilling out to 6mm. Suitable 6mm bolts are included with the wooden spreader bar pieces.*

- b) Paint the wooden tank spreader pieces with fuel-proof paint.

*Fuel proof paint is available from model aircraft shops, an enjoyable but potentially expensive visit!*

- c) Assemble the wooden fuel tank load spreading pieces on the rear end of these bolts and tighten, but do not crush the wood excessively.

*Ensure that the end of the bolt is below the level of the rear surface of the wooden pieces. Long side faces outwards*

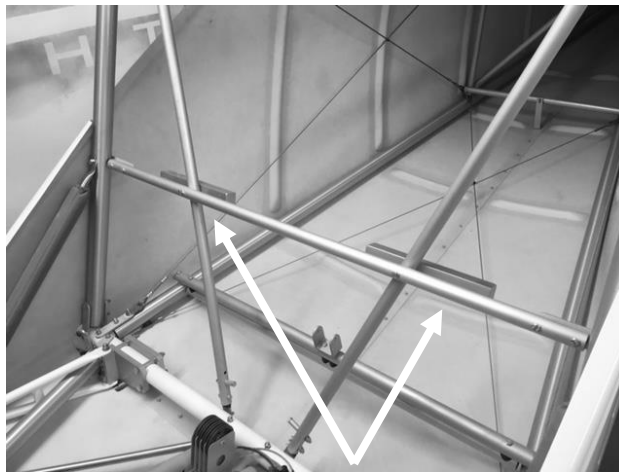


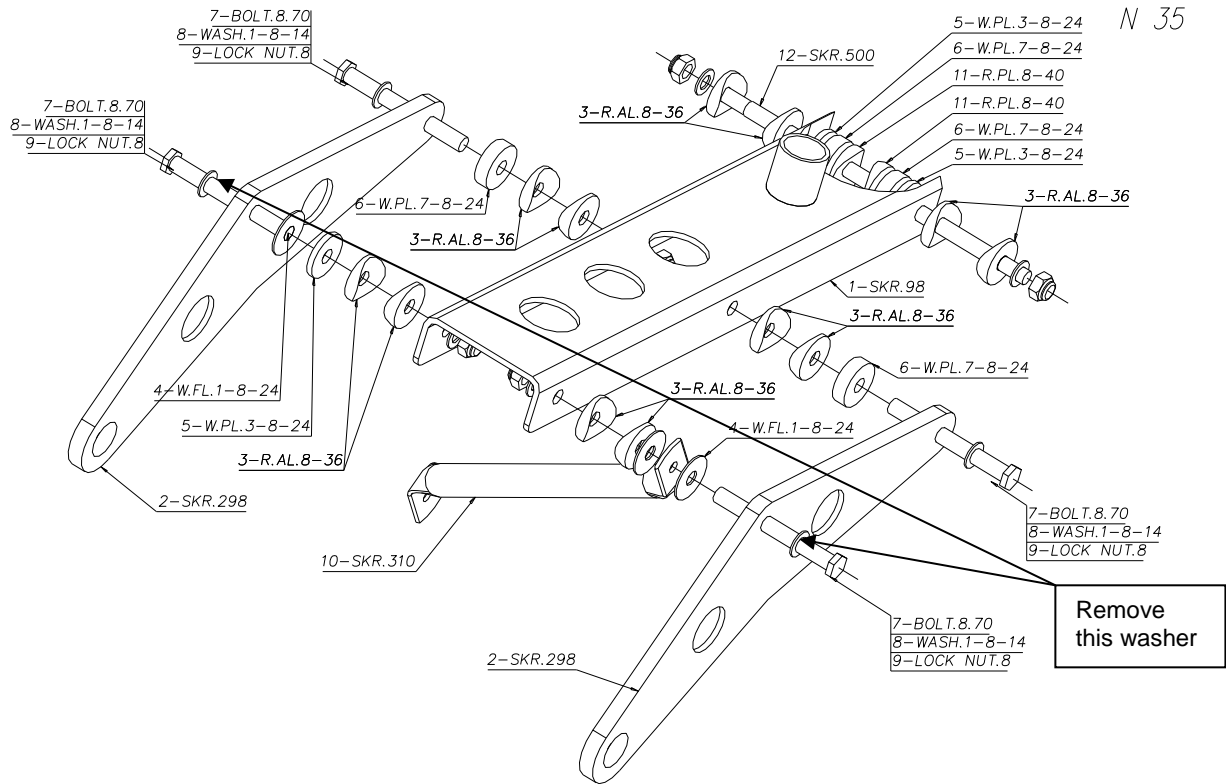
Figure 32 fuel tank wooden tank spreader pieces.

## 2.7 Engine Supports

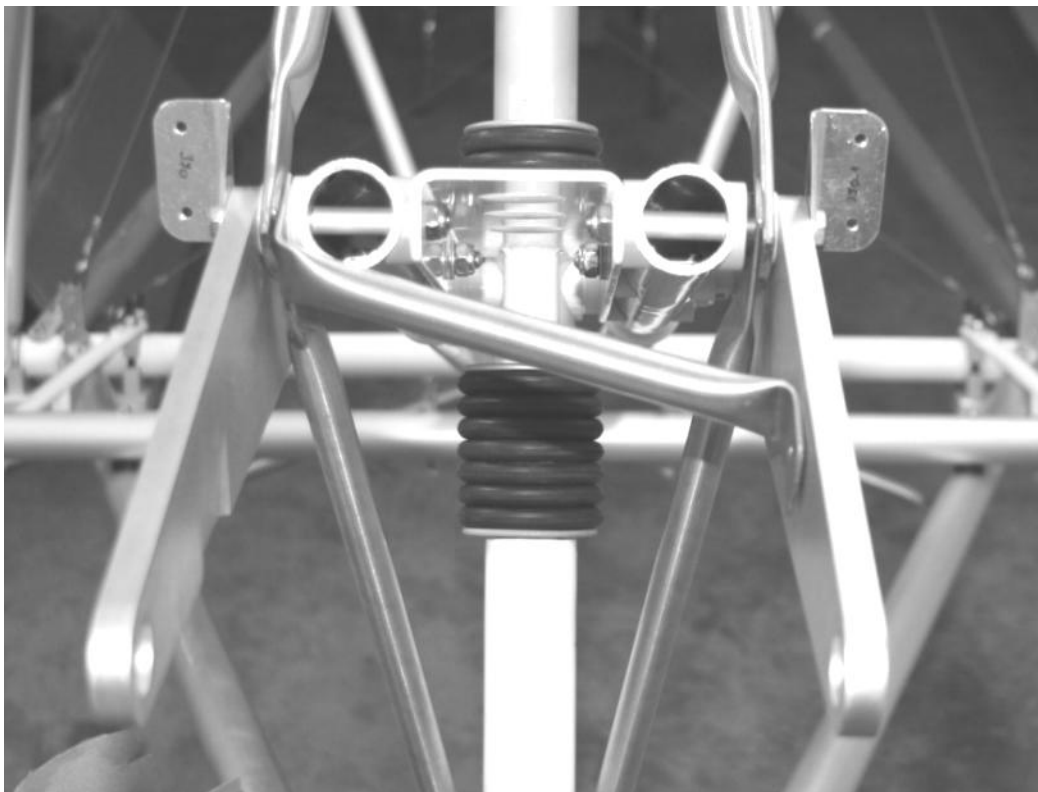
### 2.7.1 Rotax 912.



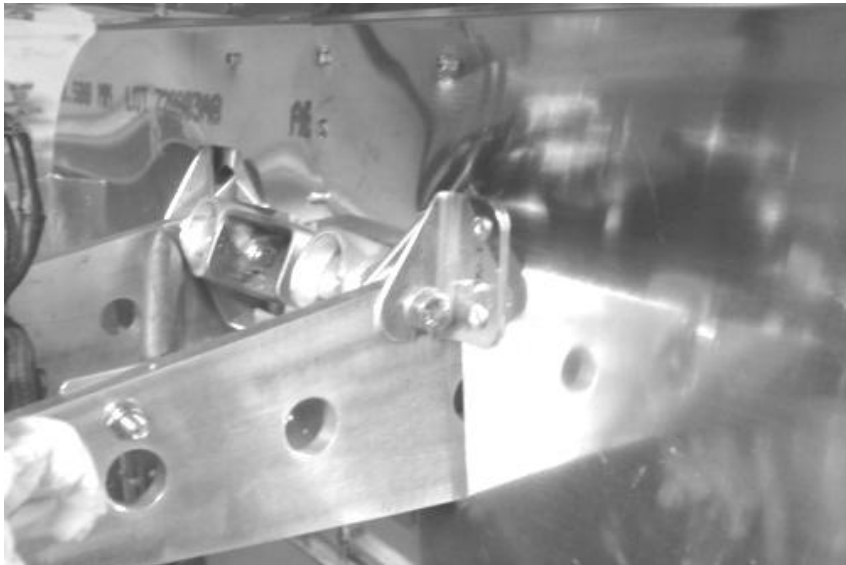
Figure 33 Rotax 912 engine mounts



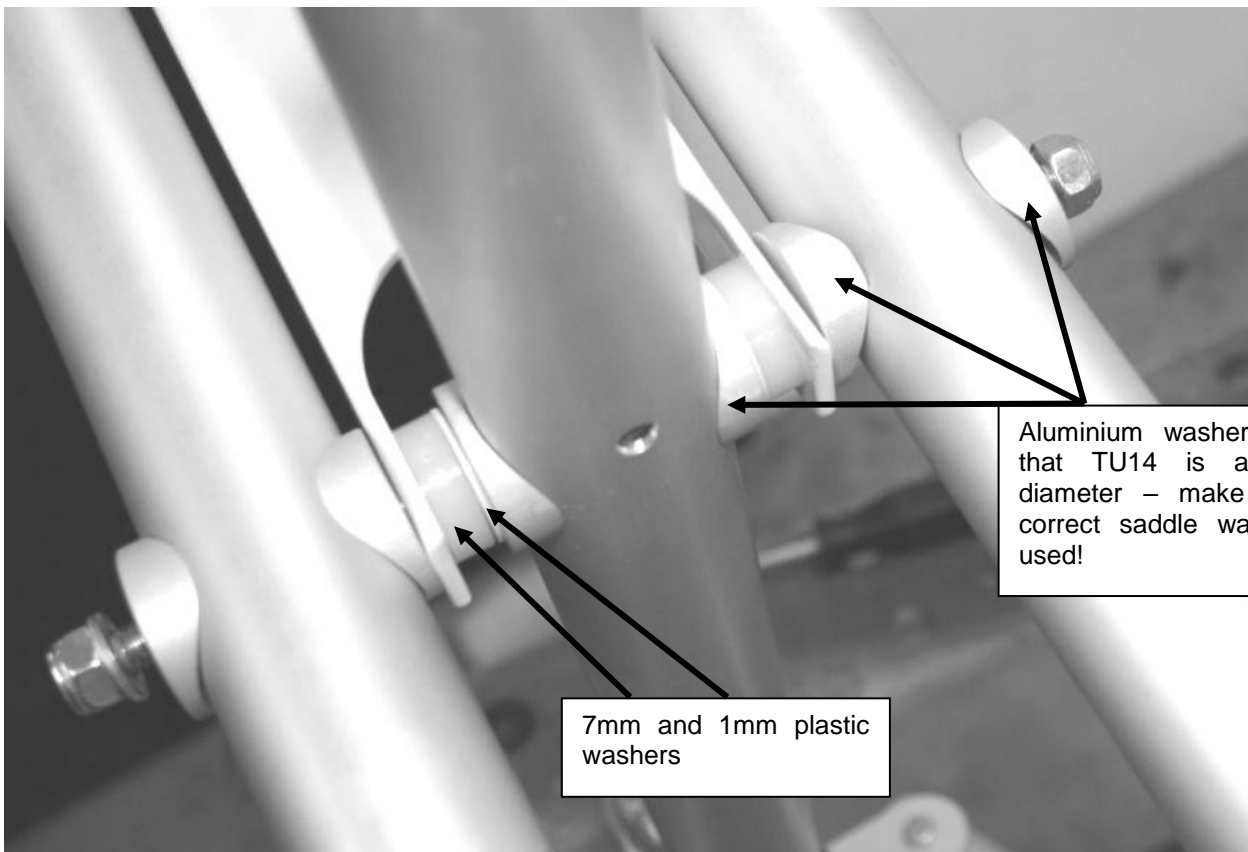
**Figure34 Rotax 912 mounting bracket – note position of TU310 is reversed for Nynja – as shown correctly below**



**Fig 35 Nynja engine mount assembly**

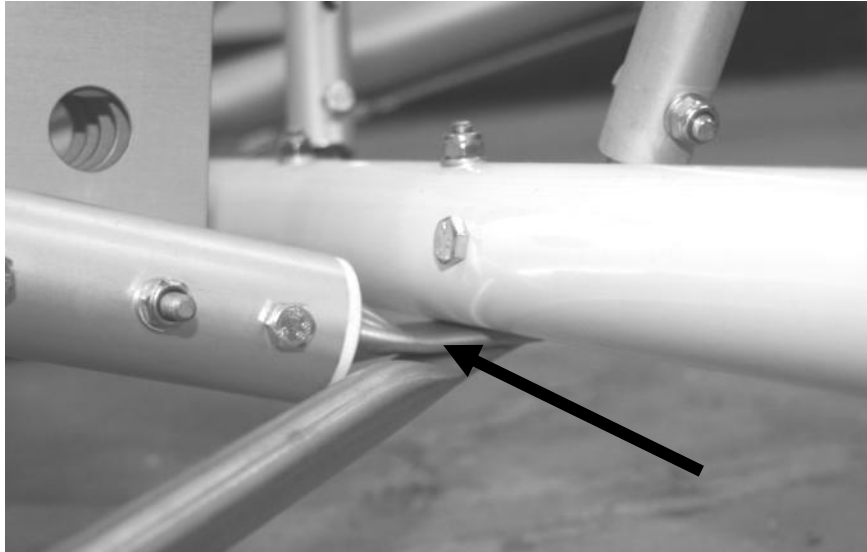


**Fig 36 Nynja firewall support brackets, should be fitted on the engine mount bolts at the front of the SKR19's at this stage as shown (normally found packaged with the instrument panel angles)**



**Fig37 liaison of TU19's, TU14 and SKR8**

- a) Locate the two central cabin tubes **SKR19** onto the front vertical **SKR14** including the steel engine mounting bracket **98** between them. Loosely bolt in place using the washers and saddle washers.



**Fig 38 Rear of SKR19 – ends must be bent to align like his**

- b) It is worth trial fitting the central cabin tubes to the underside of the main undercarriage cross-beam to allow the stainless steel brackets to be bent in a vice to align properly, Fig 38

*Before fitting the SKR98 steel engine mount it saves time later if you drill a 6mm hole near the front to fit an earth connection, picture in wiring section of manual Figure 236*

*The two plastic rings which form the aileron stops may be slid over the tubes at this stage (see the section on the ailerons in the Wing chapter), although they may require removal later by cutting them off if adjustment of the aileron movement is required.*

- c) Attach the two central cabin tubes **SKR19** onto the main undercarriage cross-beam **SKR9**.

*Remove the pulley set from the assembly and put to one side for now. This makes fitting the TU19's to the undercarriage cross beam much easier. But leave the long bolt (stud) in position through the two tubes, - which will help ensure alignment and prevent possible difficulty fitting later.*

*Note the bolts through **SKR9** should point upwards, and should pass through the stainless-steel under-seat diagonal tubes **SKR42** before passing through the central cabin tubes **SKR19** and the main undercarriage cross-beam **SKR9**.*

*The steel end pieces on the central cabin tubes **SKR19** may require bending slightly to allow them to sit flat against the underside of the main undercarriage cross-beam **SKR9**.*

- d) Loosely fix the two stainless-steel upper triangulation tubes **SKR24** to the top of the front vertical **SKR14**, including saddle washers.



- e) Loosely attach the upper and lower stainless-steel triangulation tubes **SKR23** to the central cabin tubes and the engine mounting brackets, including the alloy side pieces **298**, Figure 35 and Figure 39.

*It will be necessary to tweak the ends of the steel triangulation tubes to position them flat against the engine mount and the front vertical tube **SKR14**.*

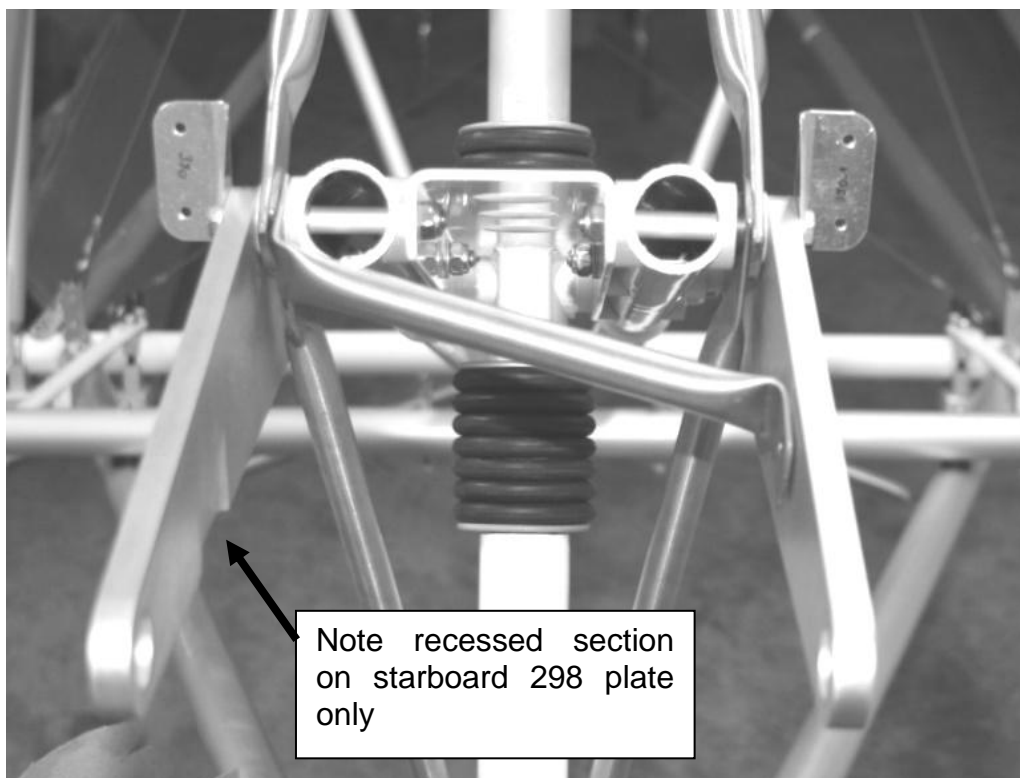
*UKMOD: the front pair of mounting bolts should have a spacer tube fitted as they pass through the two central cabin tubes **SKR19**. This allows them to be done up reasonably tight, without ovaling the tubes. This should result in thread protruding from the Nylocs.*

*If no thread is showing, the washers shown under the nuts may be omitted (washers under bolt heads should have been removed earlier)*

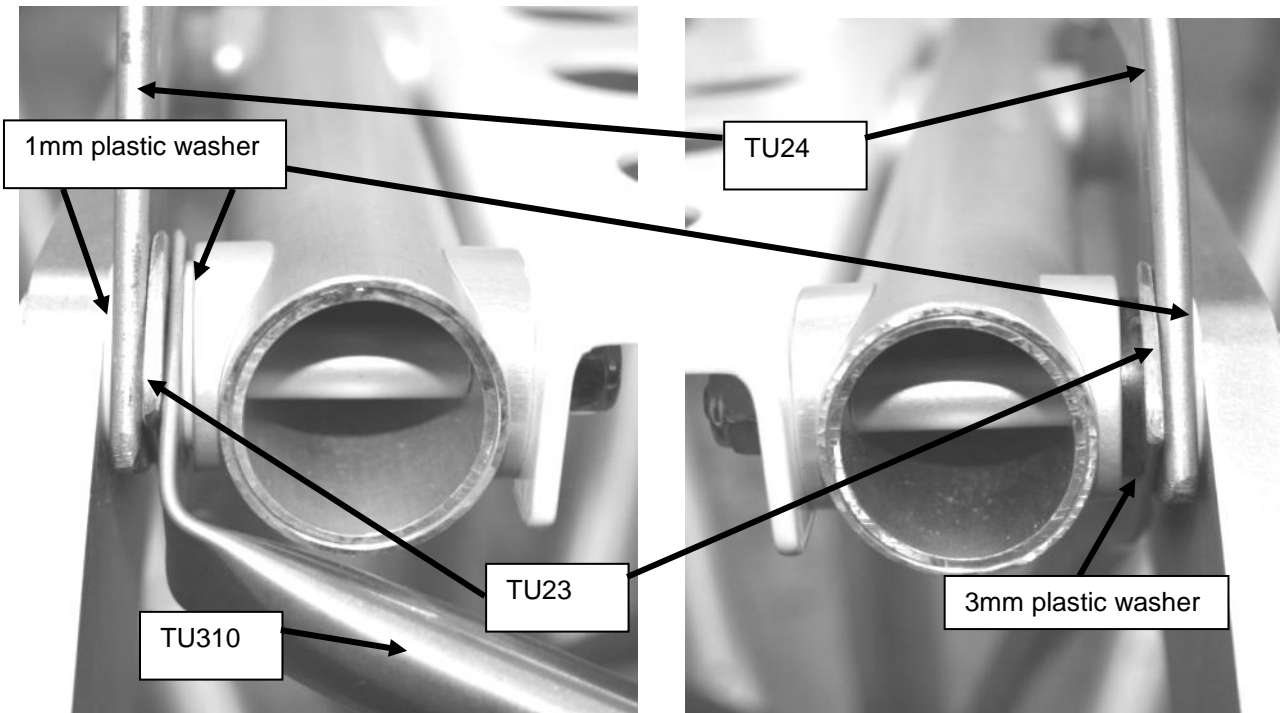
*Check the alignment of the stainless-steel parts, and tweak as necessary to get them to all lie flat against each other. This will reduce the space they occupy along the bolts.*

*Note the presence of the steel diagonal brace **SKR310** on the starboard side, and a corresponding additional thick plastic washer on the port side to assure symmetry between sides.*

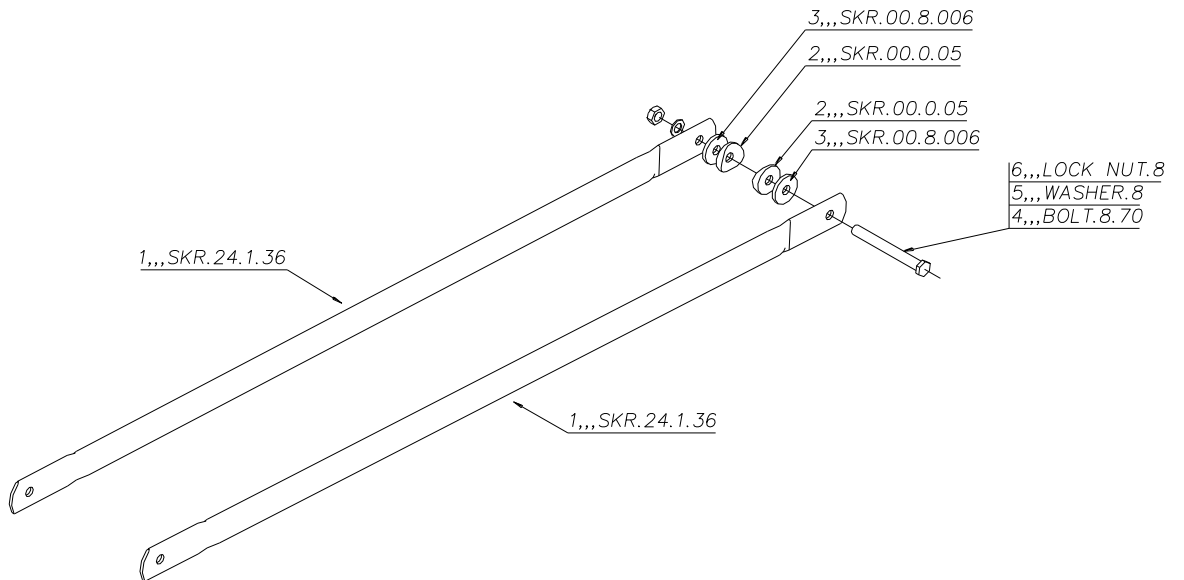
*Note that the 298 plates are handed and the starboard one has a recess machined in, as shown below.*



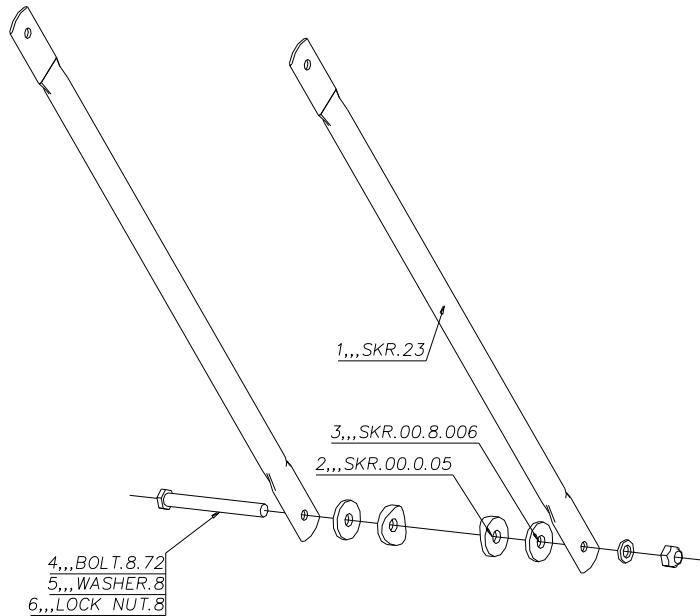
**Fig 39 handing the 298 plates**



**Fig 40 Forward end of SKR19 and Liaison of engine mount plates 298BK, SKR310, upper triangulation tubes SKR24's and lower triangulation tubes SKR23. Note arrangement of plastic washers – only fit them where shown.**



**Figure 41 upper engine mount triangulation tubes.**



**Figure 42 lower engine mount triangulation tubes.**

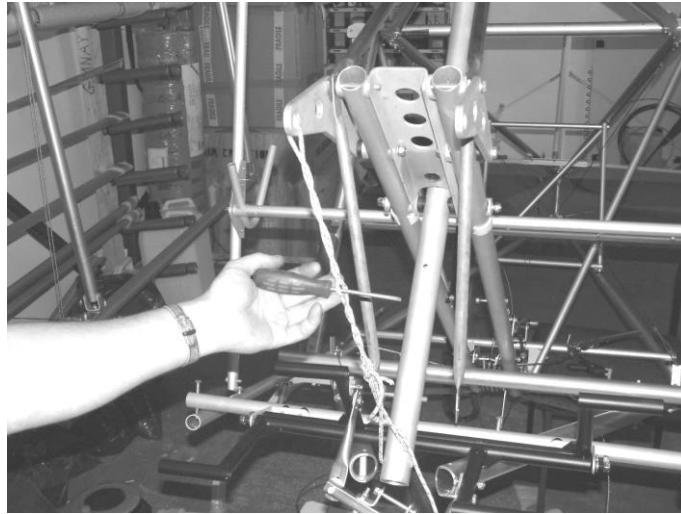
- f) Leave the bolt holding **SKR310** slack enough to rotate it out of the way when fitting the engine.



**Figure 43 lower triangulation tubes TU23 and lower engine mounts**

- g) Loosely fix the two stainless-steel lower triangulation tubes **SKR23** to the front vertical tube **SKR14**, including saddle washers, Figure 42 and 43.

*It may be necessary to apply some weight to the engine mount to fit the bolt holding the lower triangulation tubes **SKR23** to the front vertical tube, or to use a twisted rope as shown in figure 44.*



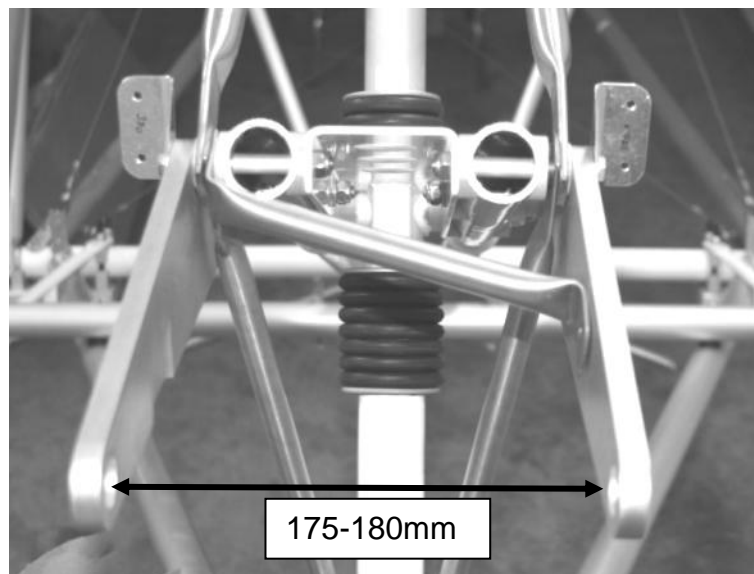
**Figure 44 twisted rope used to pull down on engine mount.**

- h) The bolts around the engine mount may now be tightened, starting with those on the mount itself before tightening the bolts holding the top and bottom ends of the triangulation tubes.

*Leave the bolt holding **SKR310** loose enough to turn it.*

- i) Check engine mount plates spacing:

*the distance between the plates should be 175-180mm, measured at the front set of holes where the rubber engine mounts fit. It may be necessary to adjust the spacer size under the rear bolts that hold the plates in position adding or subtracting 1or3mm plastic washers, to get this measurement.*

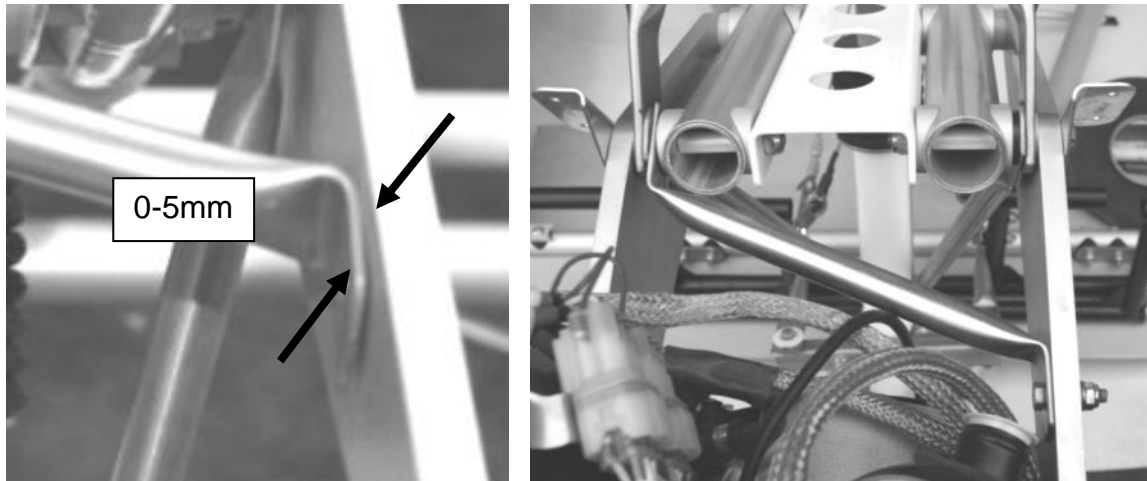


**Figure 45 Rotax 912 engine mounts, front view.**

- j) With this measurement verified, the diagonal brace SKR310 can be bent to fit in position and sit flat against the port engine plate. The plate can then be drilled and the SKR310 fixed into position with a 6mm bolt.

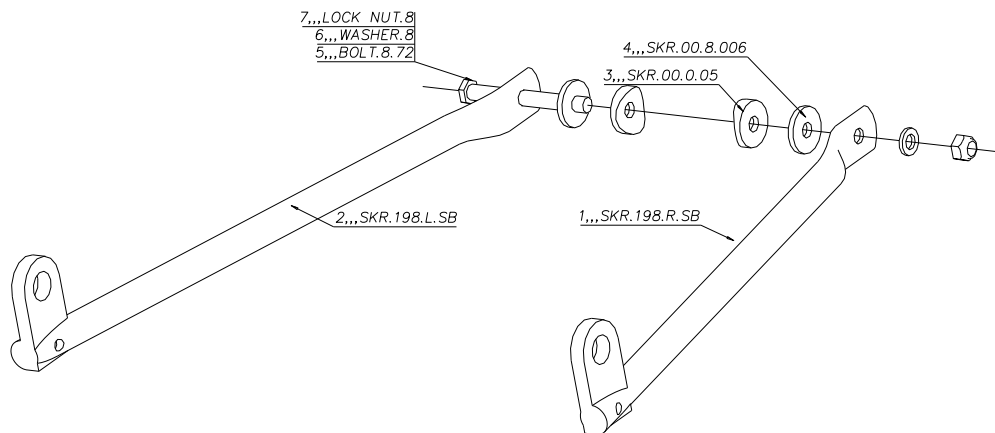
*The SKR310 upper edge should be approximately 0-5mm from the upper edge of the engine mounting plate.*

*Check that the distance between the plates has not changed during this process.*



**Figure 46 fixing position for TU310**

- k) The lower engine mounts, Figure 43 and 47, should be attached to the front vertical **SKR14**.



**Figure 47 Rotax 912 lower engine mounts.**

## 2.8 Floor

- a) The floor is supplied pre made out of composite. The grey side is the upper side. It may be surfaced with vinyl or carpet, or left as is.

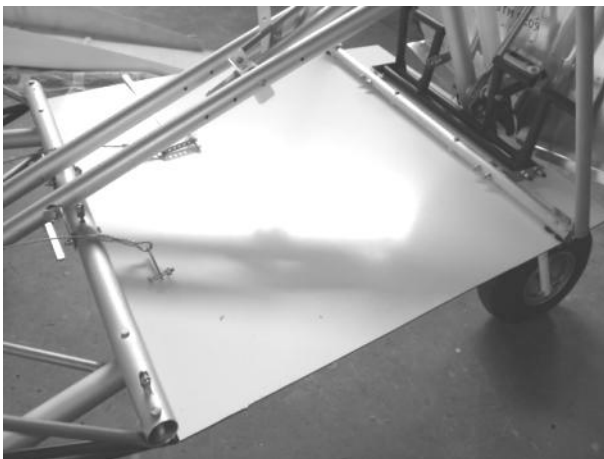
Cut a hole in the floor for the battery box:



*The hole is located on the centreline, approximately 1cm back from the rudder pedal mounting bar **SKR18**. The hole is 15cm long by 9cm wide.*



**Figure 48** battery location.



**Figure 49** view of installed floor.

b) Slide the floor in before fitting the SKR15 but first:

*Apply some of the supplied thin 2x10mm self-adhesive foam in strips along the tops of the tubes which the floor rests on, to prevent it rattling.*

c) Fit the seat front support tube **SKR15**, above the lower cabin triangle tubes **SKR12** with a pair of saddle washers per bolt between the two tubes.

*Note the tapered ends of the tube taper towards the front.*

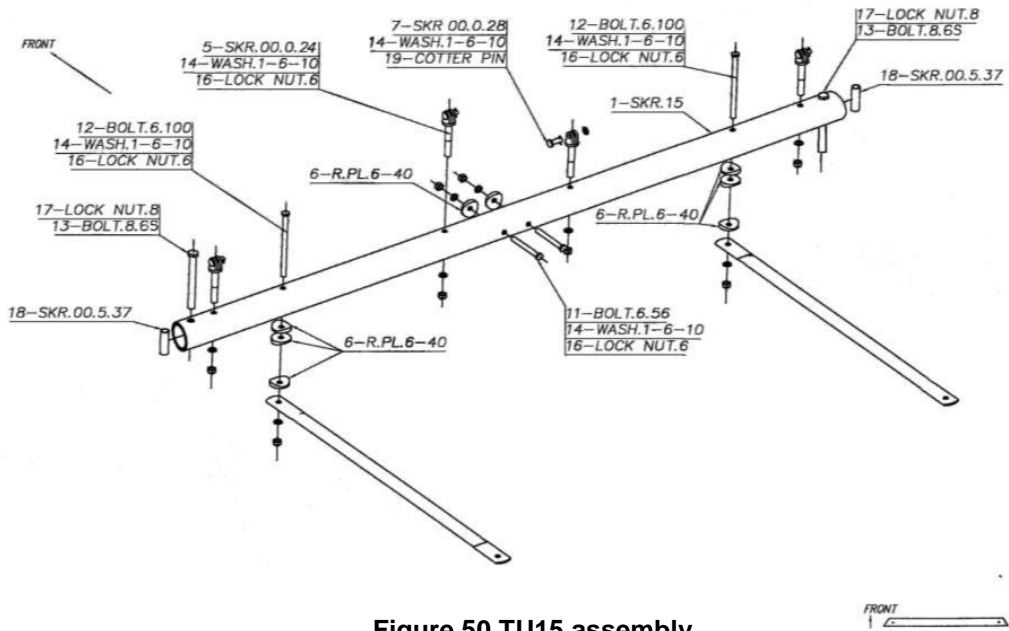


Figure 50 TU15 assembly

d) The forward ends of the steel under-seat diagonal tubes **SKR42**, which were attached to the main undercarriage cross-beam, should be attached to the bottom of the bolts securing the seat front support tube **SKR15** to the lower cabin triangle tubes **SKR12** with a thin plastic washer or saddle washer between the steel tube and the aluminium tube.

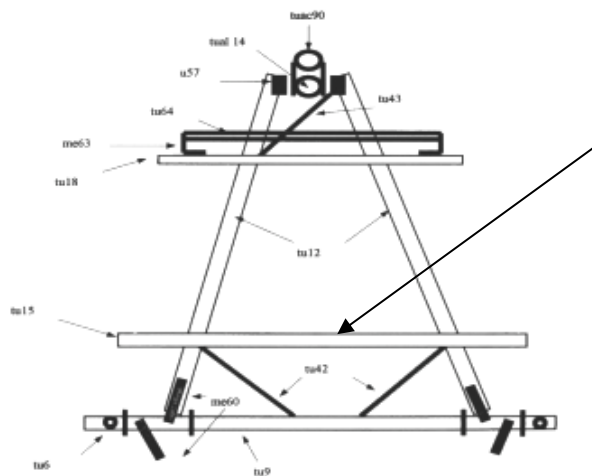


Figure 51 SKR15 seat front support tube.

- e) The floor should be slid back against the front of the seat front support tube **SKR15**.

*It should butt up against the underside curve of the tube, but not actually pass beneath it, thus preventing the floor from lifting upwards along its rear edge in negative-g situations.*

*Mark through from the bottom the positions of the holes for the rudder pedal mounting bar, and drill the floor to suit.*

*The floor passes beneath the rudder pedal mounting bar.*

- f) To further stiffen the floor in the middle of the cockpit, fit the small piece of L-section aluminium to support the floor, see Figure 56.

*This is attached by the bolts which hold the central bracing pieces, which are fitted later.*

- g) Install the battery box, and secure it with four bolts with penny washers.  
 h) Fit the webbing strap, passing right around the box through the slots in the side of the box, with the buckle at the top.

*Leave fitting the battery until later.*

## 2.9 Rudder Pedals

Refer to figure 52.

- a) Fit the rudder pedals orientated as shown on the drawing, before attaching the second of the two L-brackets if they are not already in place.  
 b) Fit the rudder pedal mounting bar **SKR18** to the top of the lower cabin triangle tubes **SKR12**, over the top of the floor.  
 c) Make sure that there are saddle washers between the pedal bar and the floor but NOT between the floor and the lower cabin tubes – this may mean removing a set from the assembly

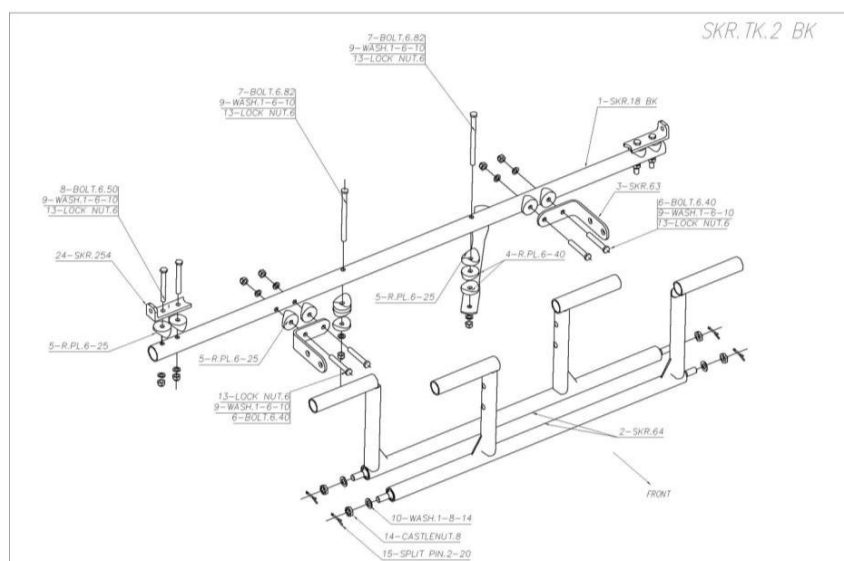


Figure 52 rudder pedals.



- d) Attach the rear end of the steel diagonal-brace **SKR43** to the bottom of one of the bolts, including a plastic washer between the steel brace and the aluminium tube.
- e) If no floor is fitted, put pieces of prop-tape on the lower cabin triangle tubes **SKR12** beneath the rudder pedals to protect the tubes from abrasion from the pedals when under load.
- f) Cut off any protruding ends of the rudder pedal mounting bar bolts beneath the aircraft, to prevent them rubbing on the coverings. Nut caps may also be fitted.

## 2.10 Control Stick Assembly

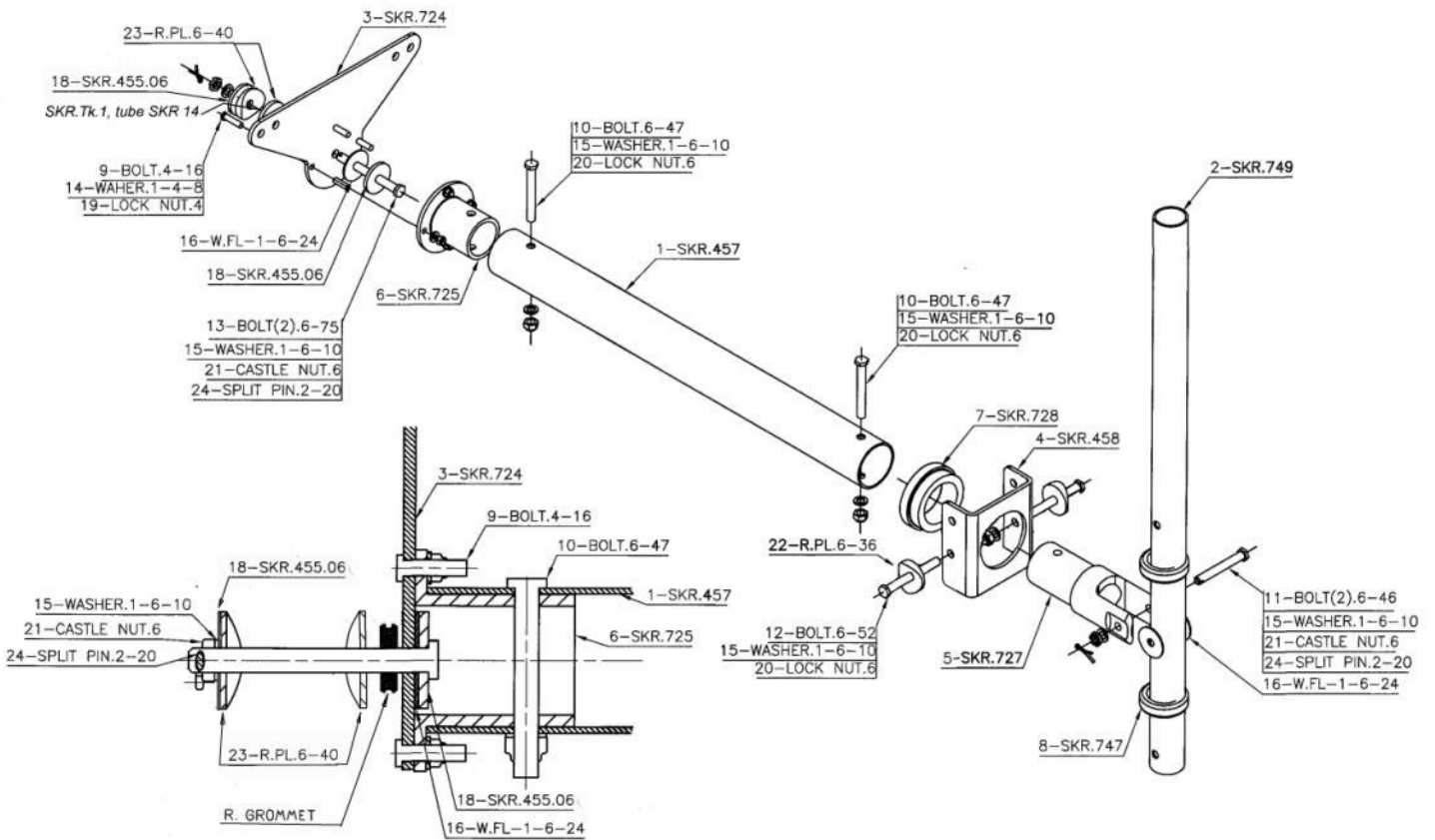


Figure 53 control stick and torque-tube parts

- a) If not already done, attach the aileron horn to the machined 'top hat' with 4mm bolts.

*Rivets must not be used here, as the fitting carries all the tension loads from the elevator controls. Use the bolts supplied, do not use any unknown strength bolts. Attach the top hat to the front vertical **SKR14** by the pivot bolt through the aileron horn, inserted from the rear.*

**The pivot bolt must be assembled in the following order:**

*Bolt head  
Large metal washer  
Plastic washer  
Aileron horn  
Rubber grommet  
Plastic saddle washer  
Front vertical SKR14  
Plastic saddle washer  
Large metal washer  
Small metal washer if necessary for spacing)  
Castle nut and split pin*

- b) When all is in final position, this should be done up tight enough to remove excess play but without discernible friction.
- c) Fit the stick to the stick pivot fork with thin nylon washers either side of the stick in the stick pivot fork.
- d) The pivot bolt should be done up just tight enough to remove any play but allow movement of the stick without discernible friction.
- e) Rubber rings are supplied to act as elevator stops. They should be positioned on the stick so as to engage on the edge of the fork jaws,
- They may be secured by glue and/or cable ties above and below them.*
- f) Fit the plastic torque-tube bearing into the rear pivot support.

*The bearing is inserted from the front. Then if the forward pivot bolt were to fail, the stick would still be held in place by this bearing.*



**Figure 54 torque-tube bearing.**

- g) The stick pivot fork end should be fitted through the plastic torque-tube bearing and into the torque-tube.

*Note that the plastic bearing fits over the fork end and is trapped in position by the torque-tube. This should be an easy fit with 0.5mm free play along the axis of the torque-tube. If this is tight it may be necessary to file the end of the torque-tube a little to prevent binding.*

*If the bearing is tight on the stick pivot piece when positioned correctly, the bearing should be abraded lightly until a smooth action is achieved.*

- h) The torque-tube can now be fitted onto the front pivot (attached to the aileron horn), and the rear pivot can be bolted to the central cabin tubes **SKR19**.

*Note that the rudder stop cables will be fitted between the rear pivot support and the central cabin tubes, do not tighten these bolts up without the stops in place.*

*It may be necessary to slot the holes horizontally in the rear pivot where it attaches to the central cabin tubes **SKR19** to allow it to take up the exact alignment of the torque-tube, but note the rudder stop cables will have some effect on this alignment.*

- i) Insert and secure the bolts holding the fittings into the ends of the torque-tube.

## 2.11 Finishing the Forward Fuselage

### 2.11.1 Tightening bolts

At this stage it is permissible to tighten most of the bolts, as the cabin frame now forms a well braced structure. The exceptions are the bolts securing the lower ends of the rear verticals to the main undercarriage cross-beam, as these will be undone when fitting the undercarriage.

Check the basic alignment of the structure as you tighten the bolts, trying not to work in such a fashion as to introduce any unnecessary distortions into the structure (e.g. don't do all the bolts up along one side and then along the other).

Remember to apply threadlock, and do not over tighten the bolts. The tubes should not be visibly distorted. Remember the bolts are not relying on their tightness to stay done-up, they only need to be tight enough to avoid the parts rattling against each other. The Nyloc and the Loctite are responsible for keeping the bolts done-up.

### 2.11.2 Central brace

- a) Fit the aluminium angles **2** and **3** linking the central cabin tubes **SKR19** to the seat front support tube **SKR15**.

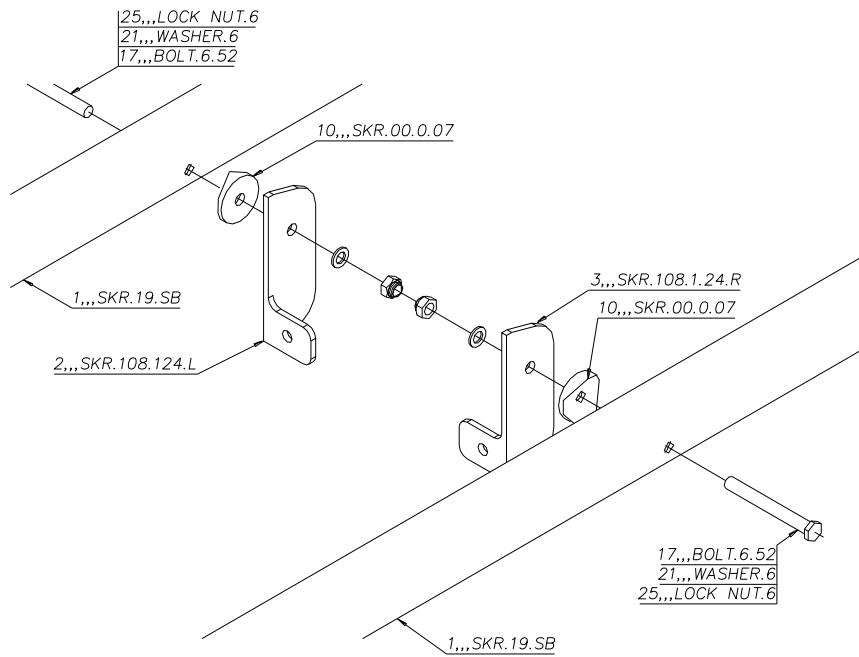
*These are not pre-drilled, as the exact hole positions are affected by the general alignment of the rest of the fuselage.*

- b) Bolt the angles to the seat front support tube **SKR15** first, then drill them to match the holes in the central cabin tubes **SKR19**.

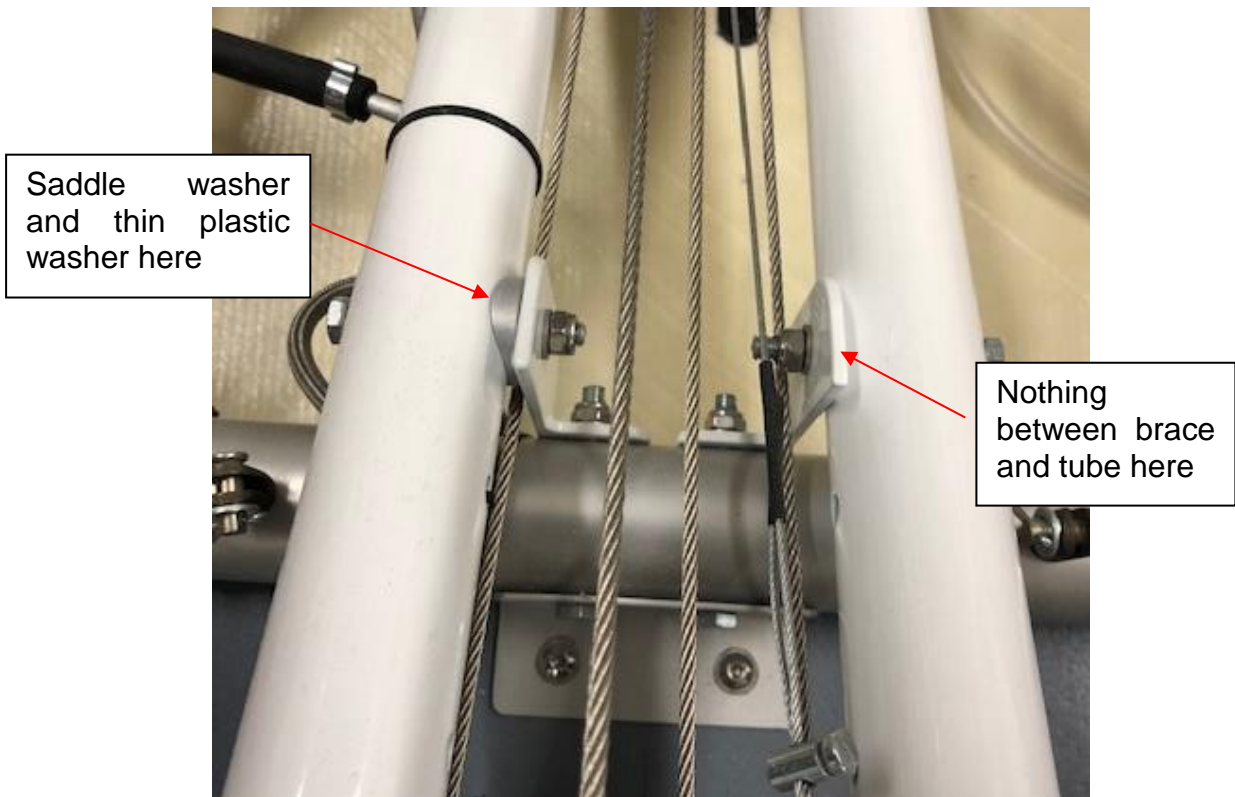
*To aid clearance for the rudder and elevator cables, it is recommended that (if supplied) both the lower saddle washers on the seat front support tube **SKR15** are omitted. This leaves only the side ones against the central cabin tubes **SKR19**.*

*To increase clearance for the rudder cables an additional thin plastic washer should be fitted between the central brace and the starboard central cabin tube, and the saddle washer should be omitted from the port side*

*The bolts should pass from the middle towards the outside, to clear the elevator cables.*



**Figure 55 central bracing pieces.**



**Figure 56 central bracing pieces.**

### 3 Rear Fuselage

The rear fuselage is composed of four longitudinal tubes, connected by the vertical fin at the tail end and braced by a single frame half way down. Steel cables are used diagonally to stiffen the structure, with tension applied by turnbuckles fitted to two of the cables.

**Once again, do not tighten the nuts until the assembly has been completed.**

#### 3.1 Tail End

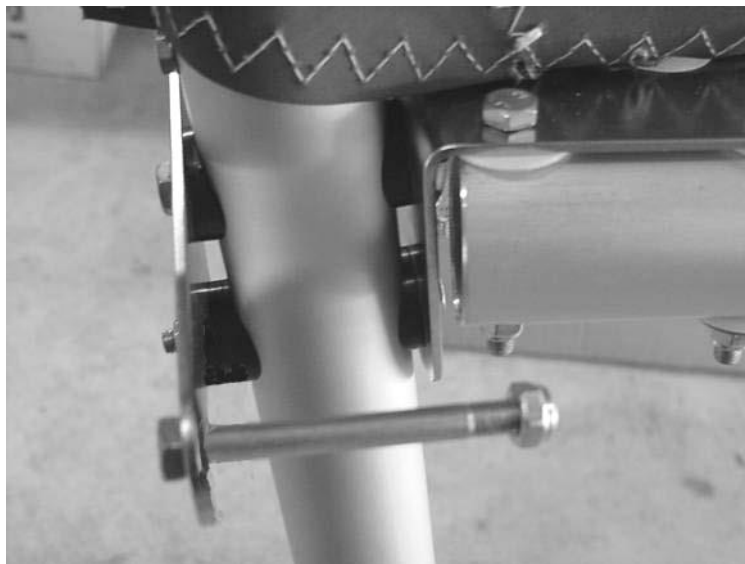
- a) Fit the rudder post (the trailing edge of the vertical fin) between the two pairs of saddle washers shown in Figure 57,58, 59.

*Do not forget the steel T-piece to which the horizontal stabiliser halves attach, and the extra flat washer on the lower bolt,*

*Some difficulty may be encountered with access to the various nuts in this area. A useful trick to hold a nut to the end of a spanner is a piece of sticky tape placed over the end of the spanner.*

*Tighten these particular nuts now using Loctite, as they are very difficult to reach later.*

- b) Fit the stainless-steel bracket in front of the rudder post, and attach the upper pair of longitudinal tubes **SKR2**.



**Figure 57 vertical fin and horizontal stabiliser rear mountings.**

- c) Attach the bottom end of the vertical fin to the bracket and longitudinal tubes **SKR4** in a similar manner Figure 58.

*If you do not have suitable supports or a helper to hold the front ends of the tubes at this stage it can be helpful to mount the bracing frame (as detailed below) to the lower pair of longitudinal tubes, followed by*

resting the upper pair of tubes on it whilst they are attached to the bracing frame and the rudder post is attached to the lower pair of tubes.

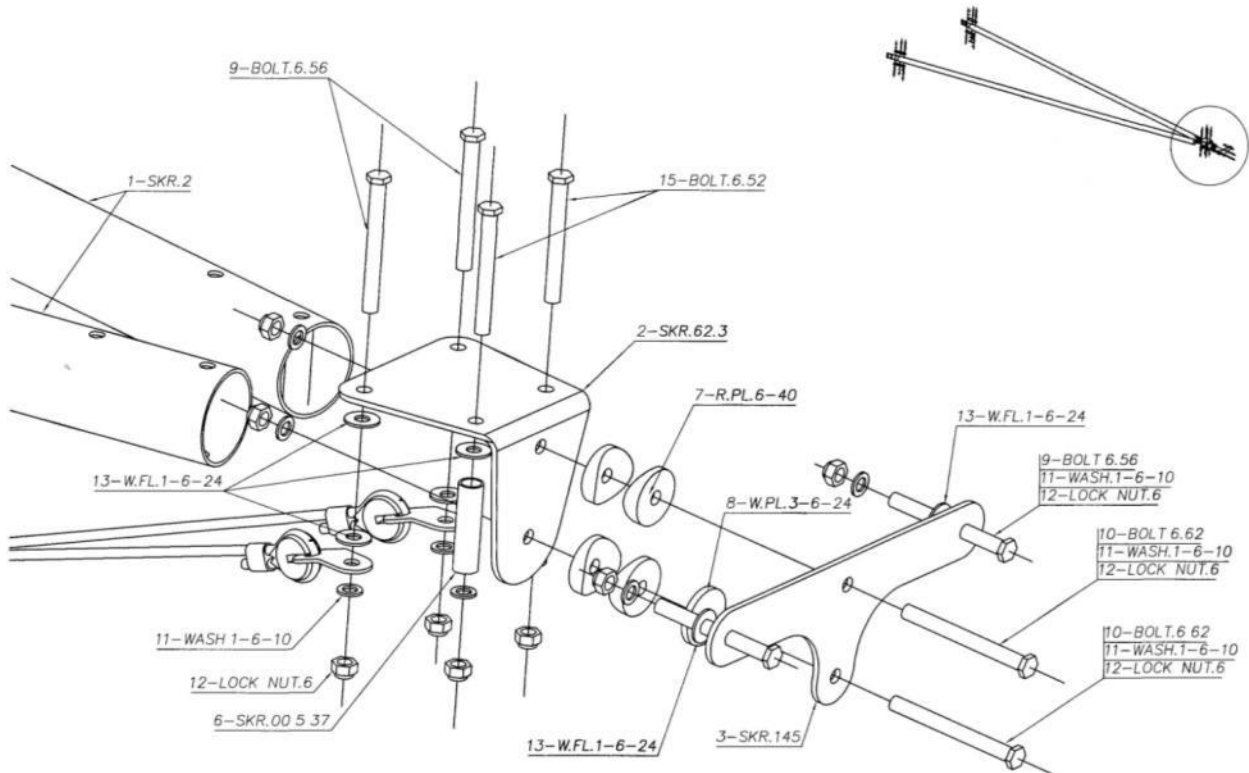


Figure 58 rear end of upper rear fuselage tubes.

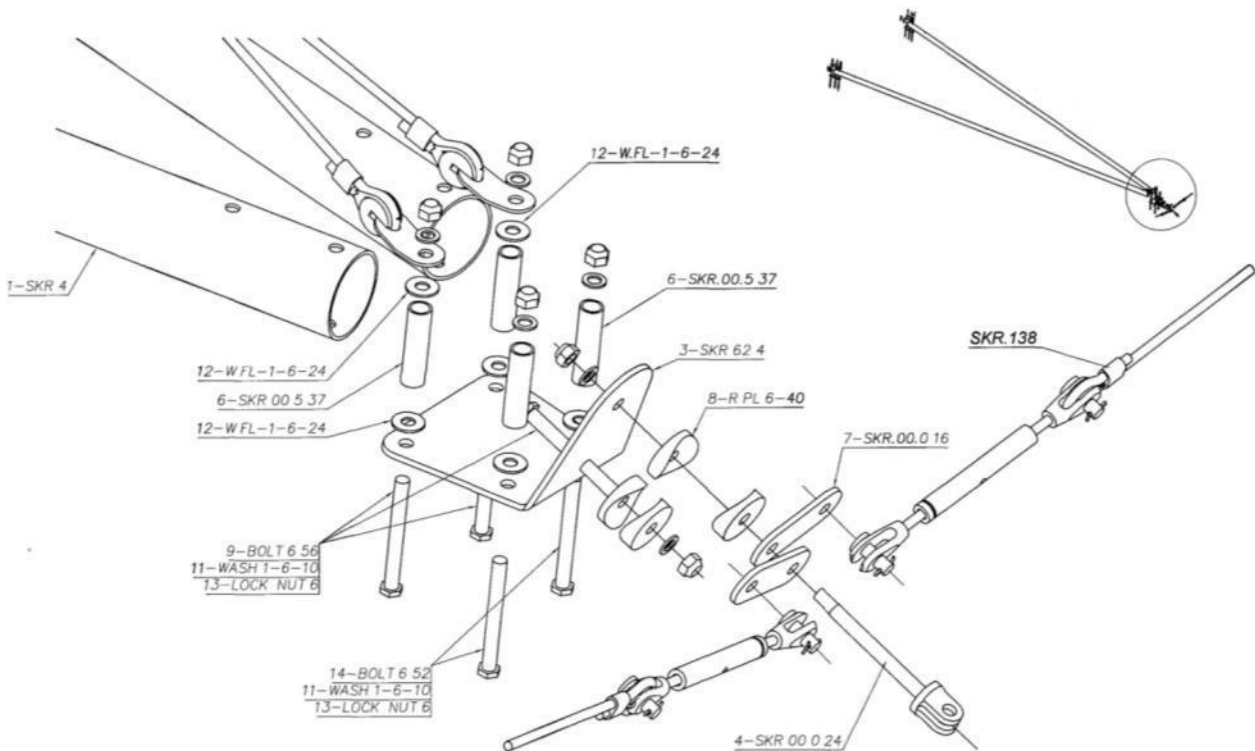


Figure 59 rear end of lower rear fuselage tubes.

### 3.2 Bracing Frame

- Fit the rear fuselage bracing frame **SKR39** to the upper and lower rear fuselage tubes using the holes approximately mid-way down the tubes.
- Check the orientation of this frame against the drawing below, as examples have been delivered assembled the wrong way around.

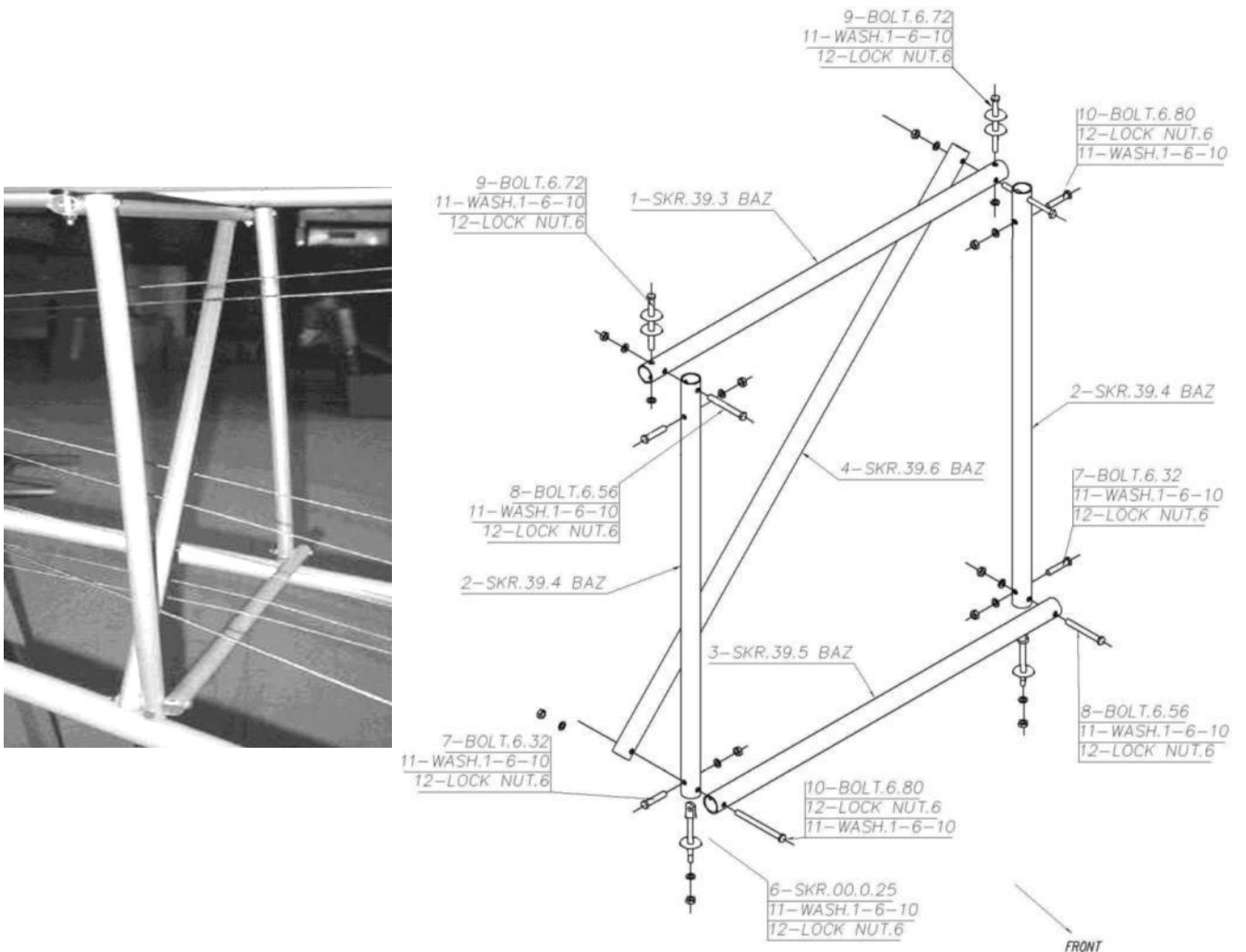


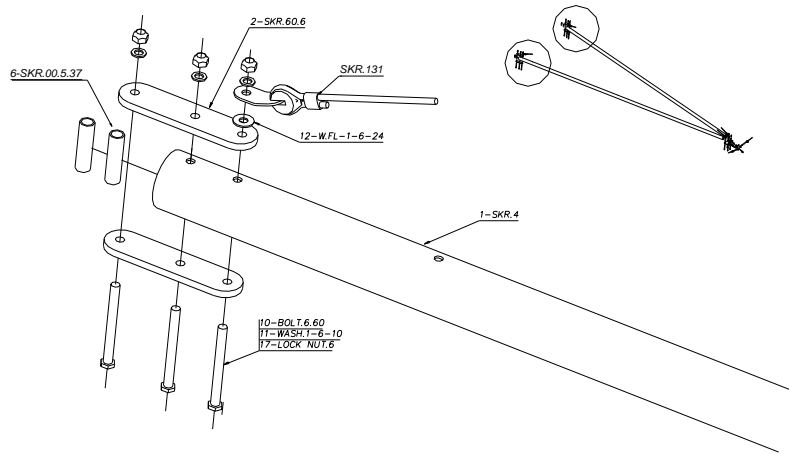
Figure 60 rear fuselage bracing frame. Note orientation arrow.

- Attach the Upper and lower bracing cables A and B to the central frame at this point. – see section 3.4 for details



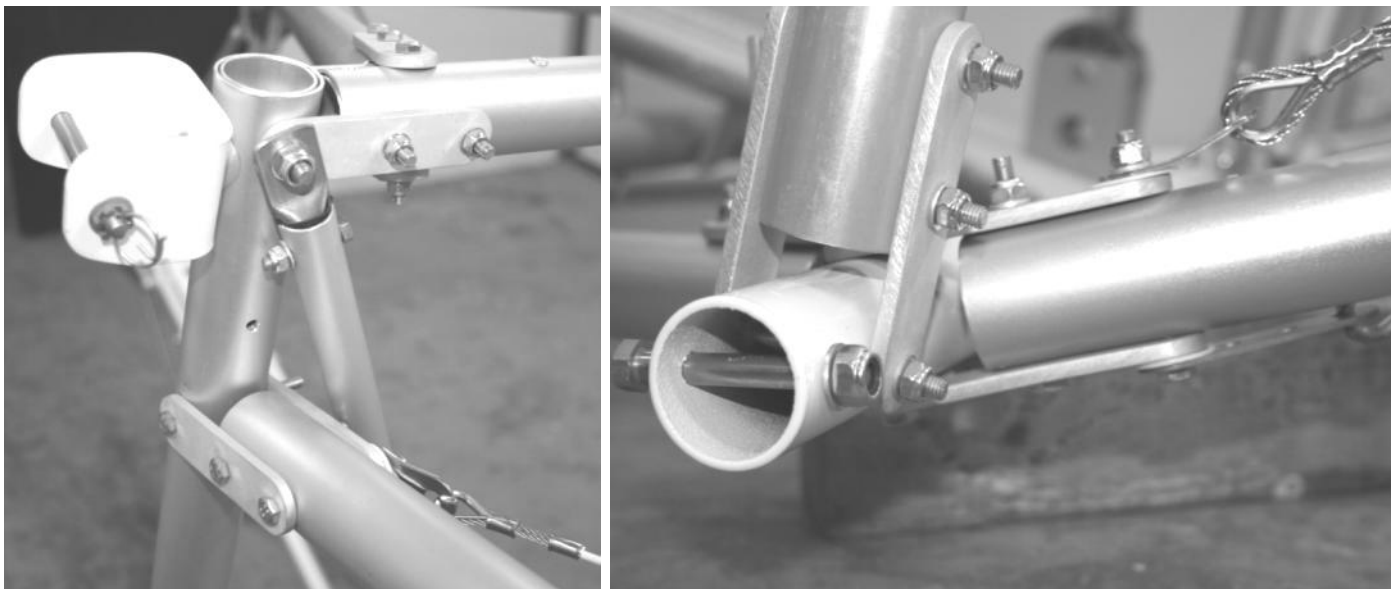
### 3.3 Front End

- a) Prepare the front ends of the lower tubes.
- b) Prepare the front ends of the upper tubes.



**Figure 61 forward end of lower rear fuselage tubes Note upper tubes have brackets orientated at 90 degrees from that shown and cables are arranged differently on Nynja. See Figure(s) 62**

- c) Mount the front ends of the upper tubes onto the SKR6 tubes as shown below.



**Figure 62 forward ends of upper and lower tubes**

- d) Attach the lower tubes to the main undercarriage cross-beam.

### 3.4 Fuselage bracing cables

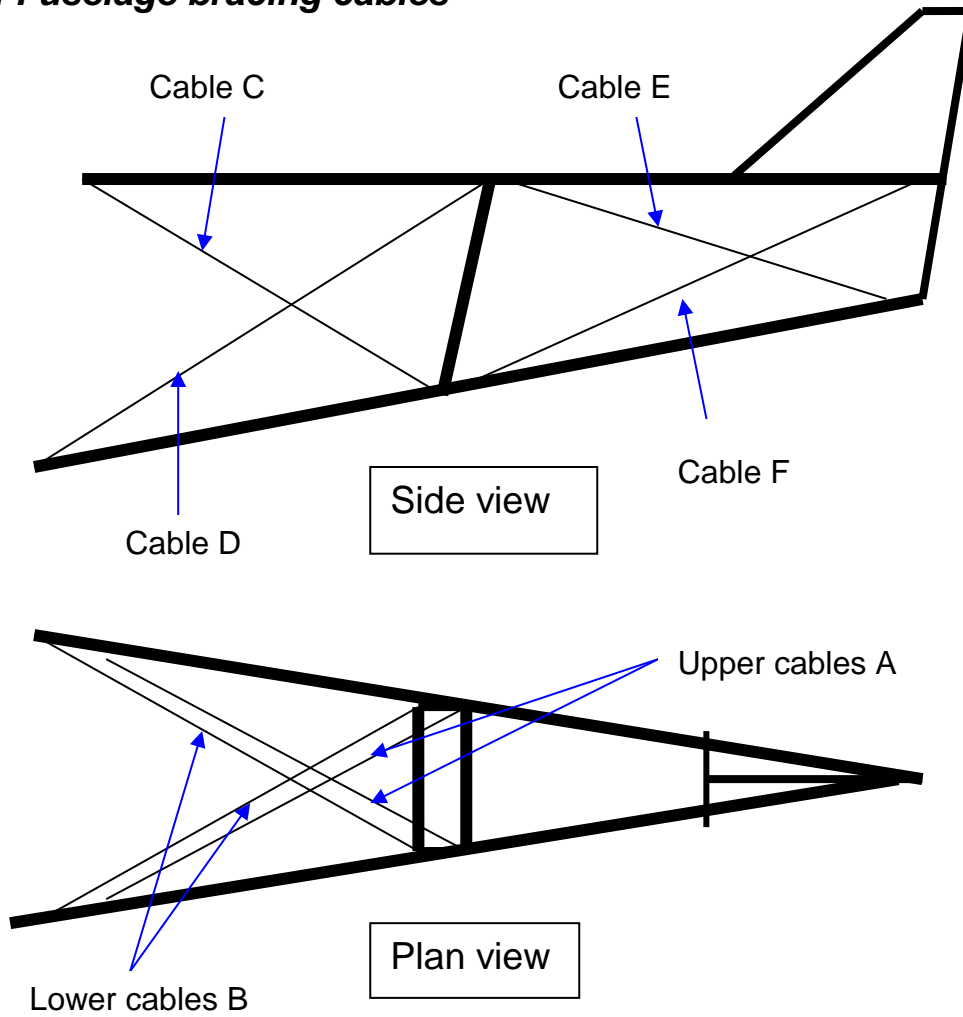


Figure 63 fuselage cable arrangement overview

a) If necessary Identify the cables from the following table:

Cable Number and thickness	length	Tangs
Cable A 2mm	1407	Forward bent, rear straight
Cable B 2mm	1578	Both straight
Cable C 3.6mm	1262	Both straight
Cable D 3.6mm	1647	Forward bent, rear straight
Cable E 3.6mm	1472	Both bent
Cable F 3.6mm	1645	Both bent

*Lengths taken from tang hole centers. Cable C is made up with a turnbuckle at the forward end and a tang. Length taken is total length from tang end hole centers with turnbuckle fully closed*

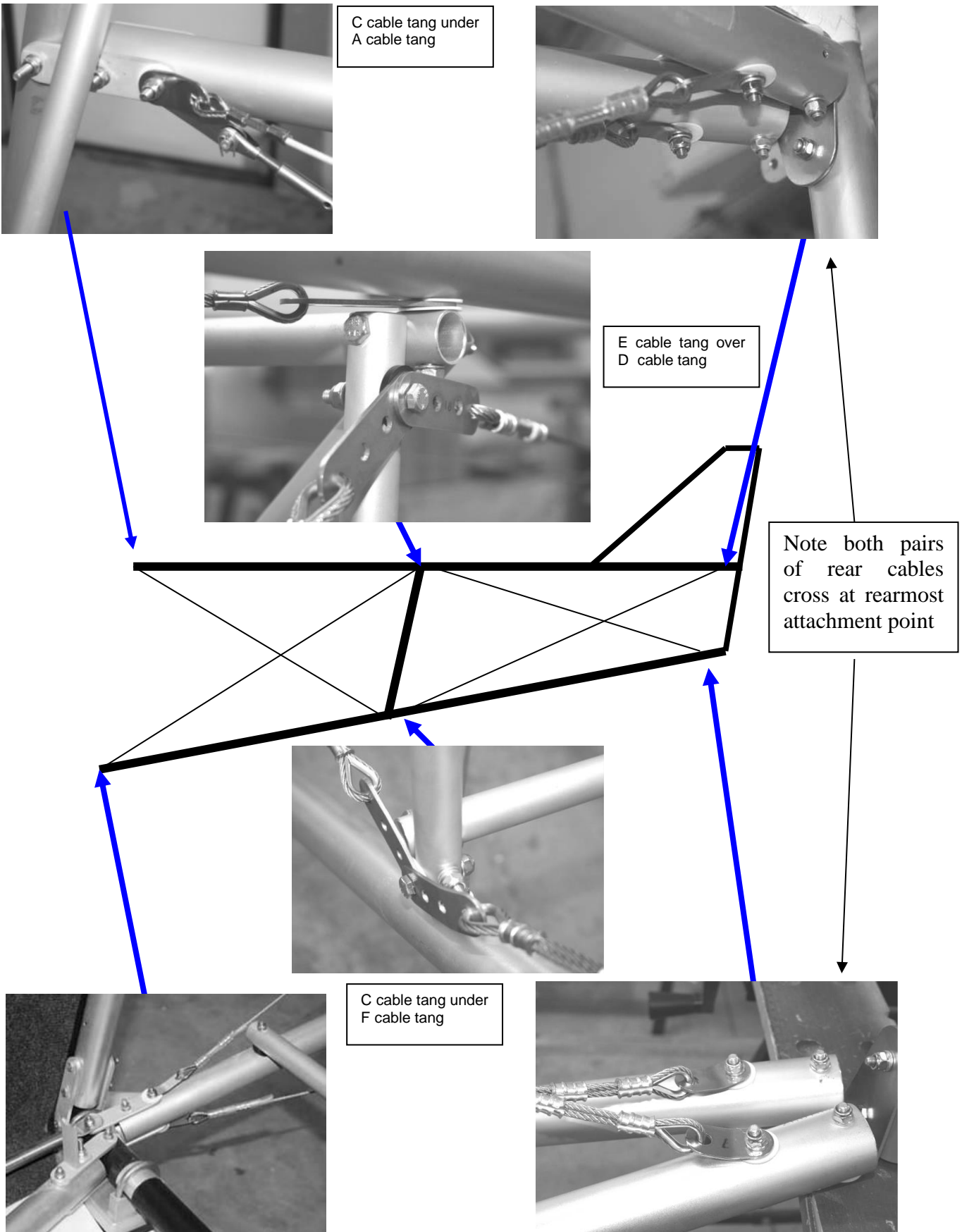
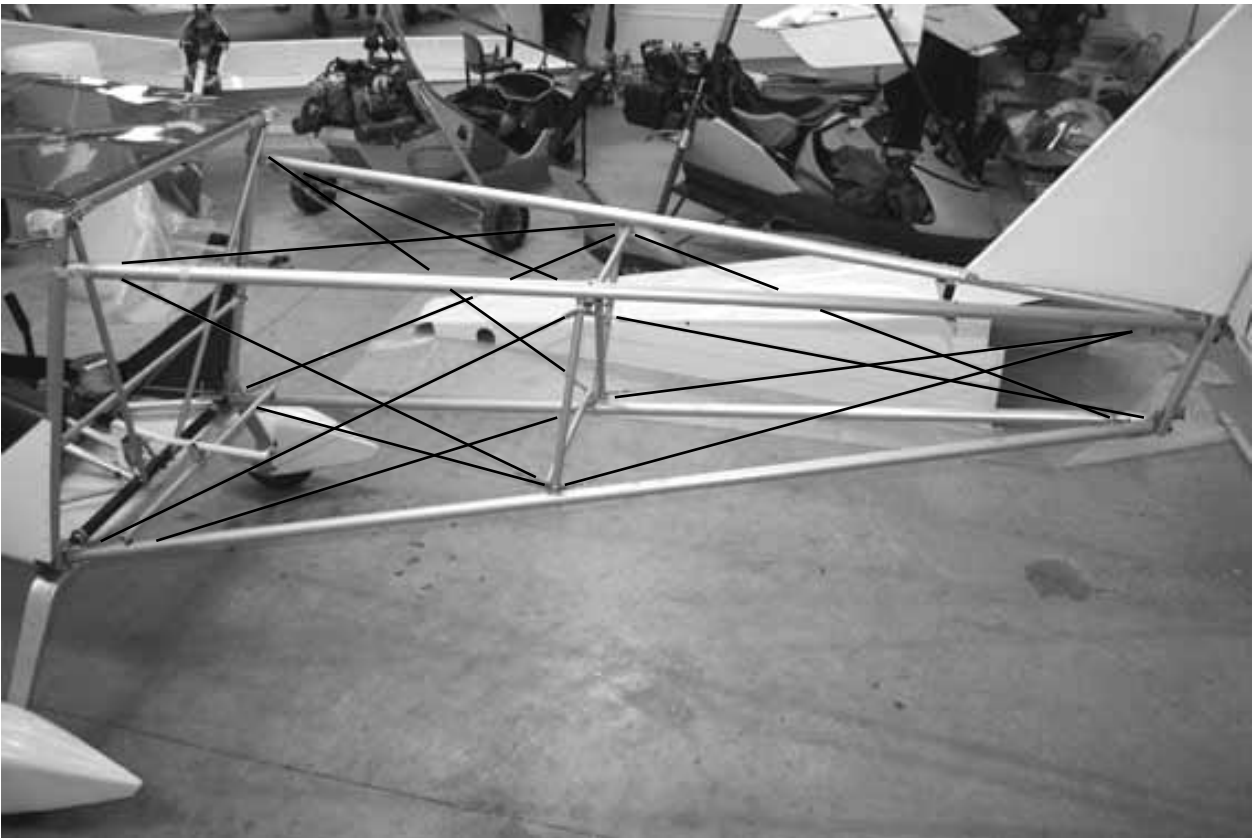


Figure 64 fuselage cable ends detail



**Figures 65 cable arrangement further overview**

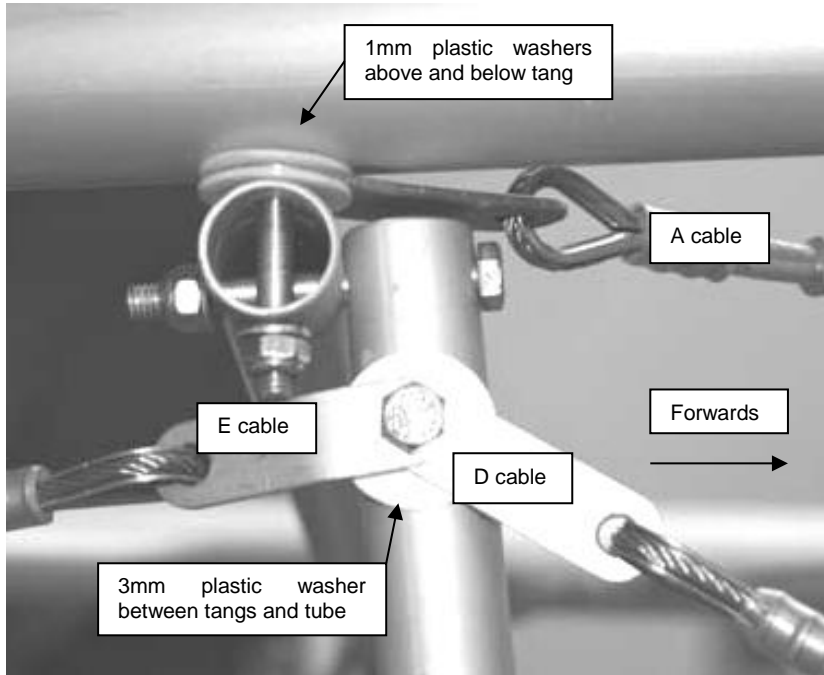


Figure 66 cable arrangement Upper starboard side of central frame

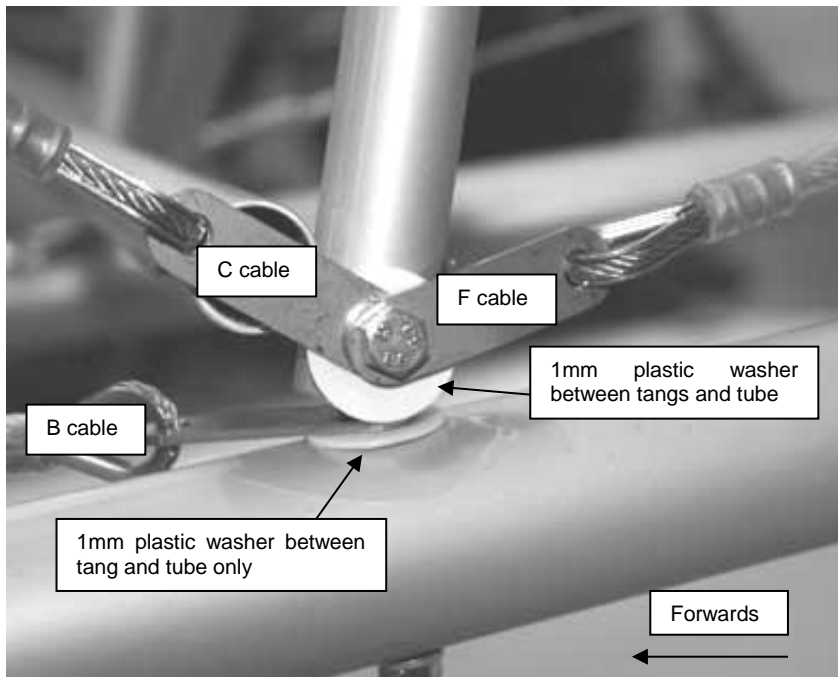


Figure 67 cable arrangement lower port side of central frame

b) Loosely fit all cables in the positions shown, and with tangs overlapped as shown above. Note tangs may have multiple holes. Only attach through the very end ones!

c) Forward side bracing C cables.

*These are the only cables with turnbuckles. Tensioning the turnbuckles sets the tension in D cables also, and permits adjustment of Fin angle.*

d) The tension in the rear cables E and F is provided by attachment at rear. Fit first on very end of bolt with nut only just engaged.

*The rear of the fuselage can be lifted which will aid attachment of E cables at front position. Fuselage rear can be pushed down to aid attachment of F cables at front position. Twisting the cable in the direction of the cable layup can be used to shorten the cables if necessary. The aim is to eliminate all slack at this stage as much as possible and it still be possible to attach them. Final tensioning of these E and F cables is achieved by tightening the rear attachment nuts.*

e) Upper bracing cables A. Should first be fixed at the rear.

*The wires should be twisted as necessary to eliminate slack to make the cable a tight fit on the start of the forwards fixing bolt. Final tensioning is achieved as the forwards fixing nuts are tightened.*

f) Lower bracing cables B should be fixed at the rear first.

*They should be twisted to provide tension and fixed at the front Inserting the bolts at an angle initially and levering straight to tension the cable as they are fully inserted. Take care not to lose the spacer in the tube – use another bolt or thin screwdriver inserted at the top to hold spacer in position and bolt is withdrawn and reinserted.*

g) Apply light tension to the cables but do not tighten at this time.

### 3.5 Tailplane Front Mounting

- a) Attach the aluminium corner section **SKR22**, figure 68, to the upper rear fuselage tubes **SKR2**.
- b) Test fit the tailplane halves between this front mount and the rear mounts.

*There should be a thin plastic washer or saddle washer at the rear, and a small saddle washer at the front. If the bolt head at the front of the tailplane contacts the front mount, an additional plastic washer may be used.*

*The SKR22 may be supplied with slotted mounting holes. This is so it can be adjusted slightly fore and aft for the tailplane fit.*

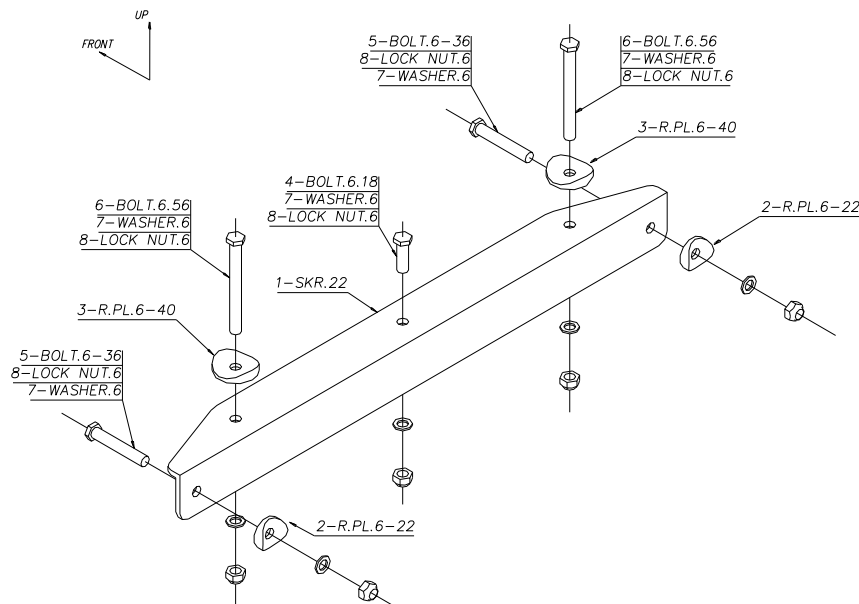
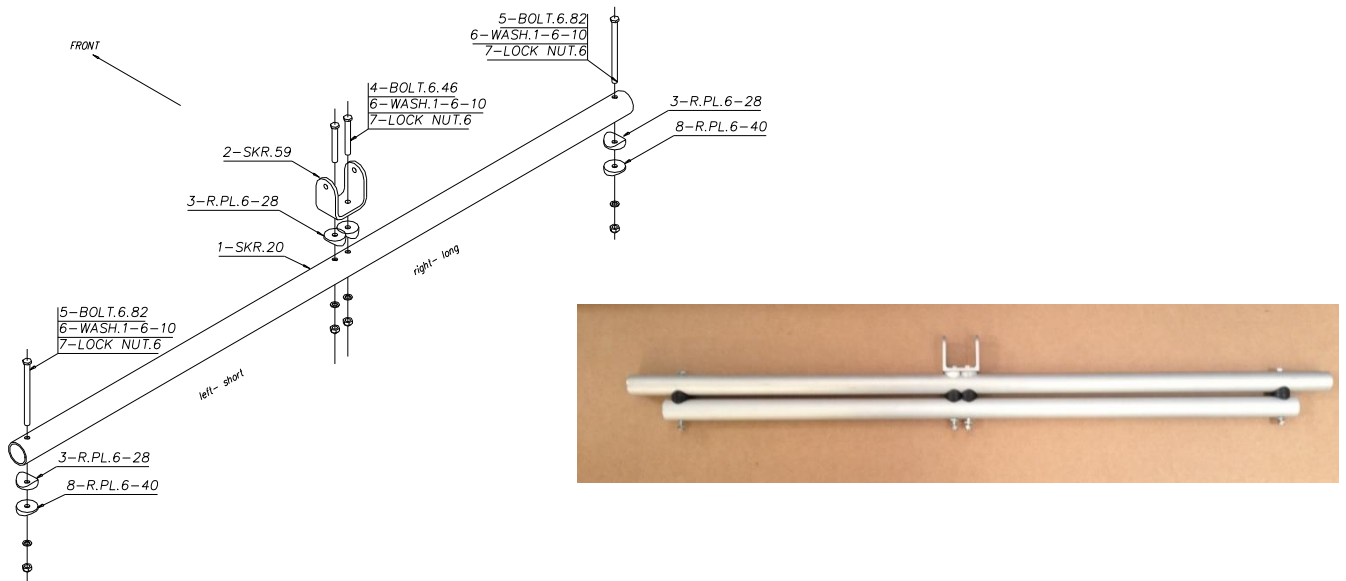


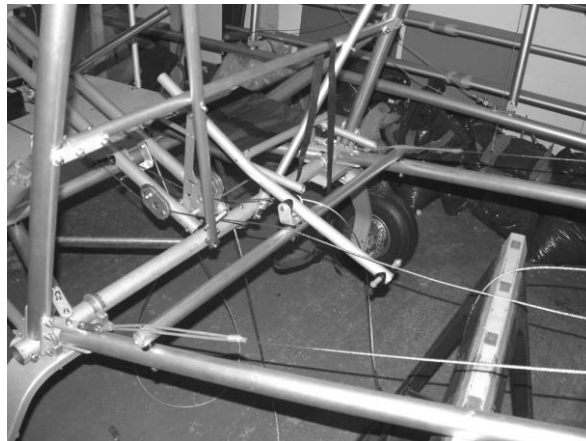
Figure 68 vertical and horizontal stabiliser front mounting.

### 3.6 Fuel Tank Support and Flap Handle



**Figure 69 fuel tank support / flap handle mount – M version left – LS version on right.**

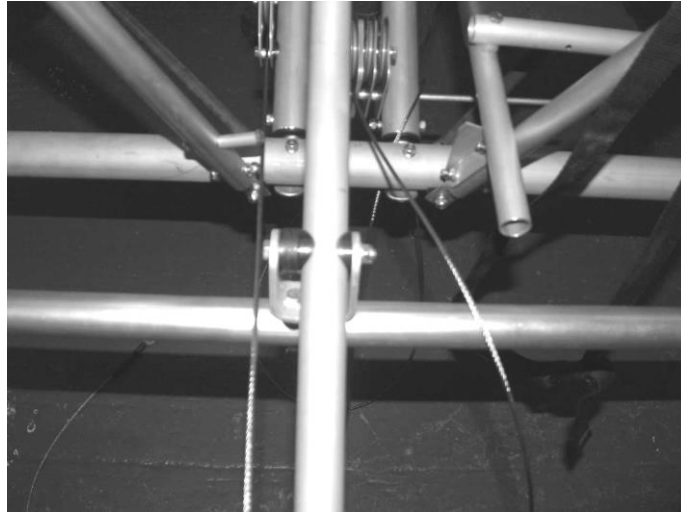
- a) Fit the fuel tank support **SKR20** to the lower rear fuselage tubes **SKR4**, with the U-bracket located towards the port side of the fuselage and facing upwards, Figure 69 and 70.



**Figure 70 flap handle and fuel tank support bar.**

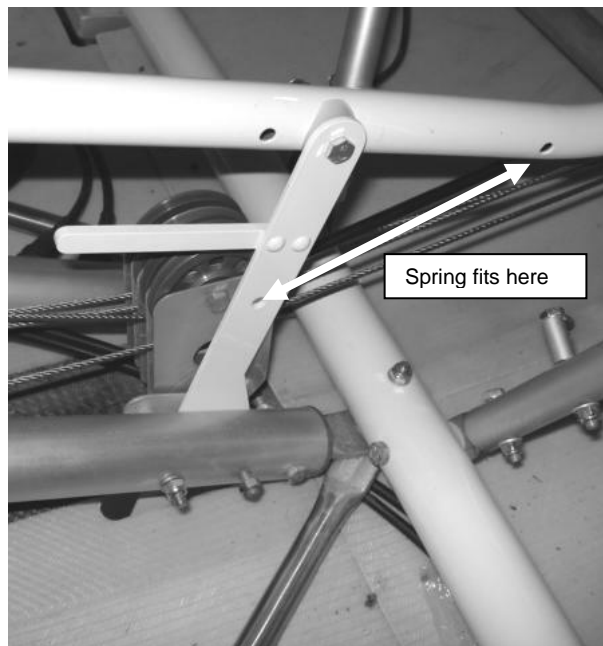
- b) Fit the flap handle to the U-bracket, biasing the flap handle tube as far to the starboard side of the bracket as possible, leaving only one saddle washer between the handle and the starboard side of the bracket, figure 71.





**Figure 71 flap handle pivot.**

*Do not space the detent lever away from the handle, use only one thin plastic washer or a single saddle washer between them. It is permissible to bend the lever slightly into a Z-shape to make it align with the flap handle and the latching slot. Take care to make only smooth bends and not near and holes – or it can fracture!*



**Figure 72 flap lever detail**

- c) Fit the S70 spring from the flap handle to the detent lever, in position shown in figure 72. The eye end may need opening up slightly to fit in the rear hole

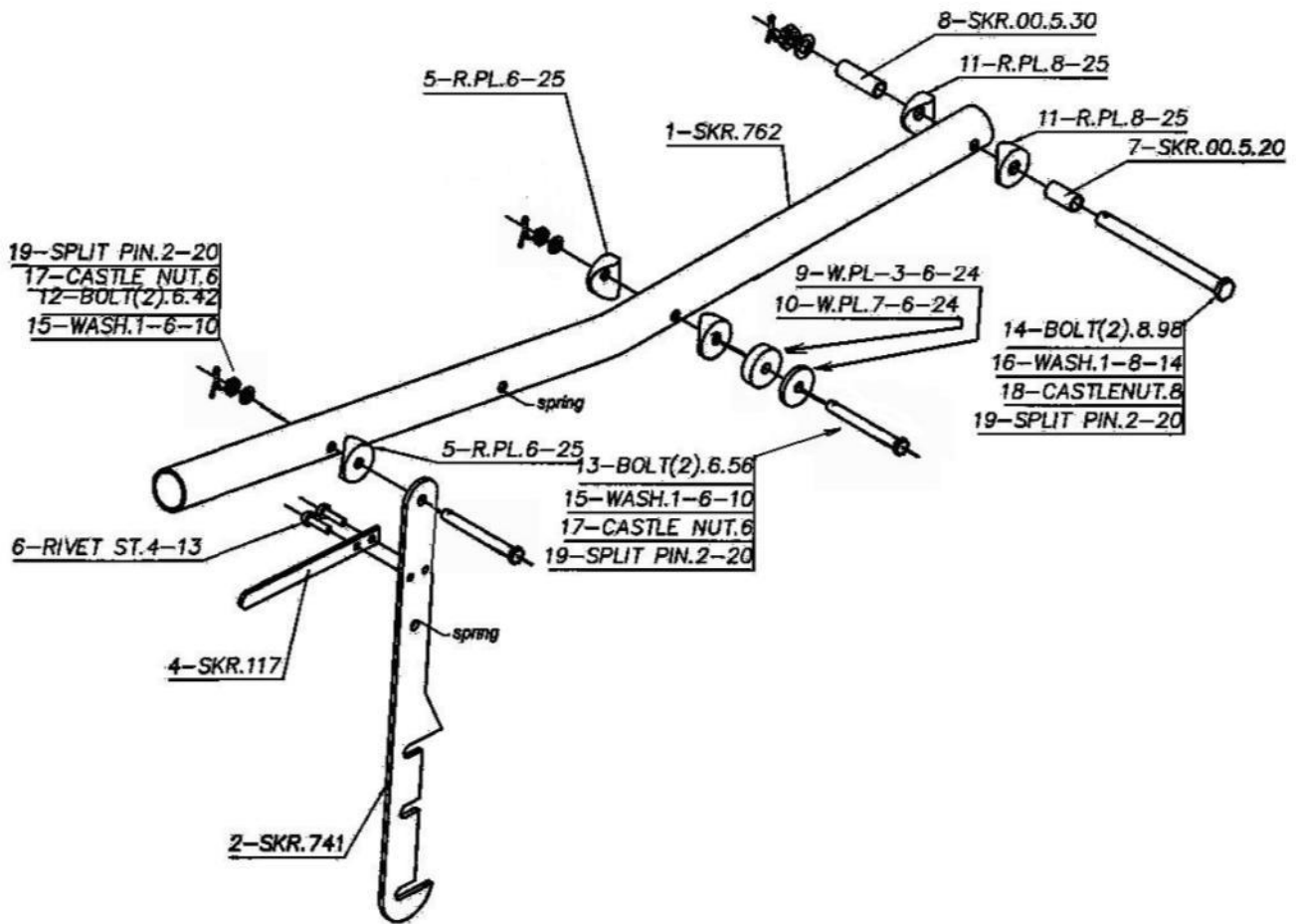


Figure 73 Flap handle

***Not Tightening the Bolts and cables!***

Do not finally tighten the bolts or cables around the rear fuselage at this stage – this will be detailed later after the landing gear is attached.

## 4 Undercarriage

### 4.1 Wheels

All three wheels and tyres are identical, only the hubs differ between the nose wheel and the main wheels, which are fitted with brake discs.



Figure 74 wheel parts.

- a) Place an inner tube inside a tyre, Figure 75.
- b) Loosely place the tyre onto a wheel half with valve hole, locating the valve through the hole in the wheel half.



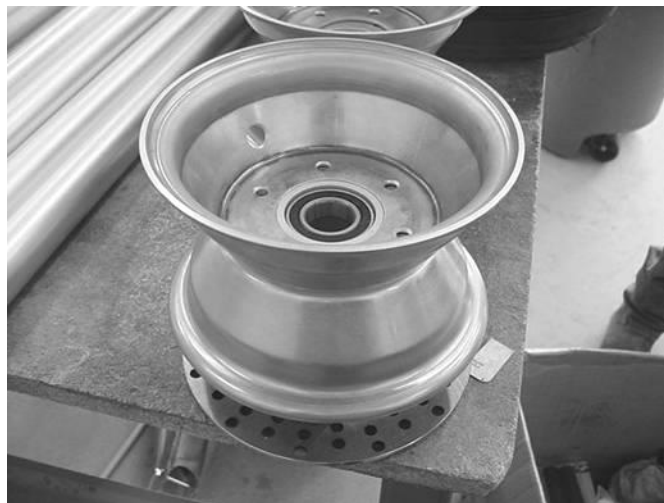
Figure 75 tyre and inner tube.

- c) Place the other wheel half onto the first wheel half, so that the tyre and inner tube are positioned between the two wheel halves.
- d) Take a hub, put a drop of thread lock into each of the six threaded holes, and position it against the wheel half opposite the valve side, Figure 76. Note that the hub has a machined face with square inside corners one side and a radiused face the other. The machined face should sit against the wheel halves. **Do not assemble with hub between wheel halves!**

- e) Check that the inner tube is not trapped between the wheel halves, and pass all six bolts from the valve side through their washers, both wheel halves, and into the threaded holes on the hub.
- f) Tighten the bolts and inflate the tyre to 26psi. If the tyre does not slip easily into position a little squirt of neat washing up liquid around the rim can be used to make it slip more easily.



**Figure 76 placing a hub against the wheel halves.**



**Figure 77 a wheel minus the tyre.**

## 4.2 Main Undercarriage

### 4.2.1 Brake calliper attachments

- a) Check that the callipers are bolted together by the correct bolt to leave the other two holes free to mount the calliper offset slightly to the rear of the undercarriage legs. See Figure 88 for the manner in which the callipers are intended to be mounted.

*It will probably be necessary to swap the bolt holding the one of the callipers together to the other hole. This will result in a handed pair of callipers.*

- b) If not already done, drill an 8mm diameter hole in each undercarriage leg 18mm above the upper rear stub axle mounting holes, as shown in Figure 78.

**Mark carefully, and recheck before drilling.** Use a small pilot drill first, and recheck its position. Then drill out to the proper size.

*Try to drill squarely. It is permissible to allow a little slop in the hole size, to allow the callipers to find their own alignment.*

**Take care to make a handed pair.** The callipers and holes for them are to the rear of the undercarriage legs, and at the narrow end of the legs.

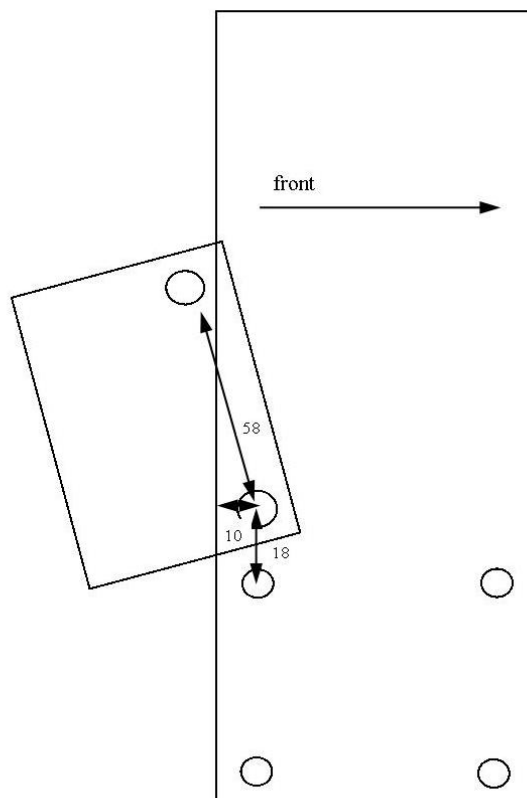


Figure 78 hole for brake calliper mounting.

## 4.2.2 Undercarriage legs

- a) If spats are to be fitted, fit the mounting brackets on the lower pair of stub axle mounting bolts on the wheel side of the stub-axle flange, figure 80.

*Use the longer bolts supplied in the spat kit. Excess bolt threads can be trimmed off. The bracket may need relieving with a file if there is interference with the stub axle weld*

- b) Fit the brake mounting piece to the forward upper stub axle bolt, and tighten the stub axle bolts.

*Note if spats are fitted the stub axles should be attached with the outer fixing bolt vertical – not horizontal as shown below.*

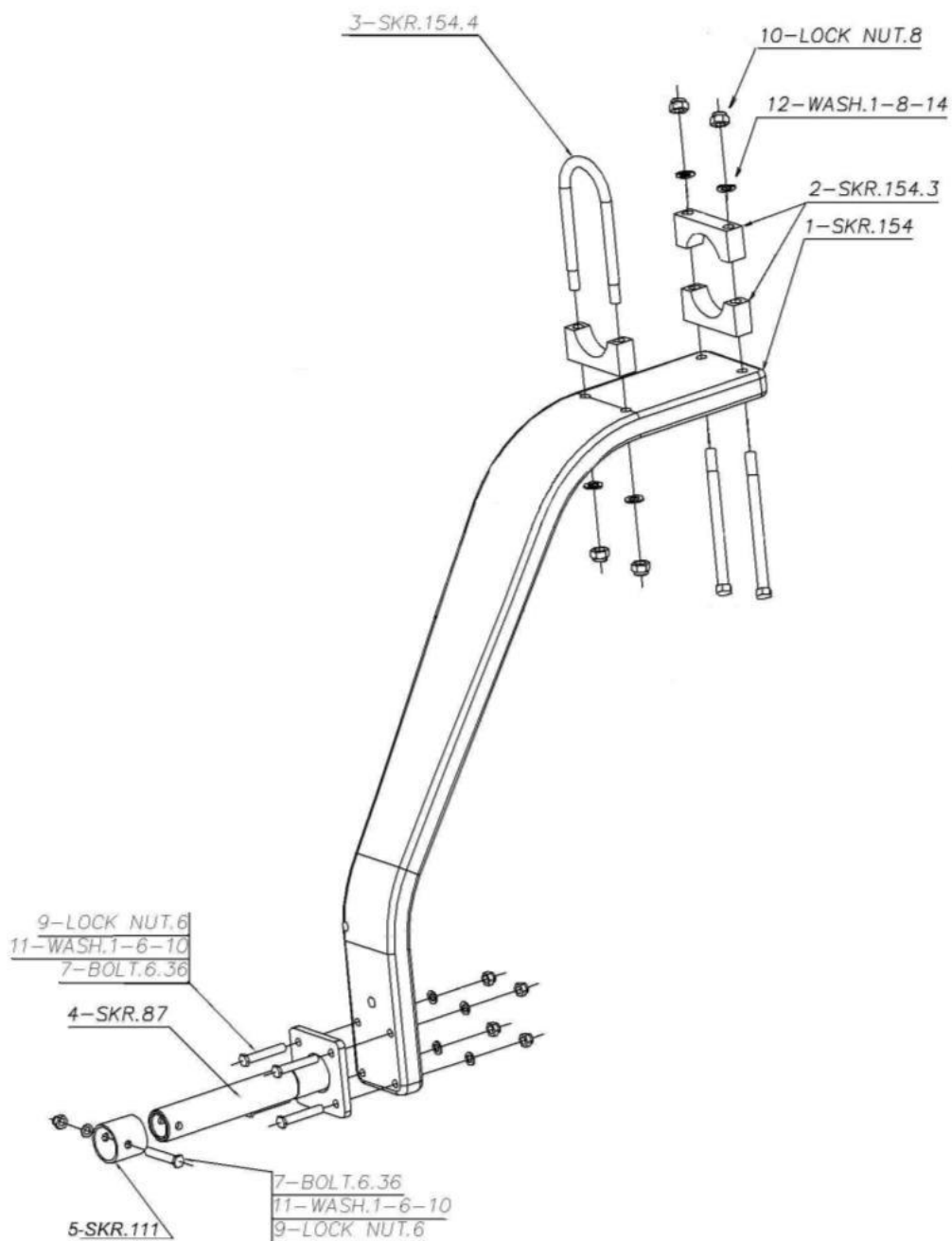
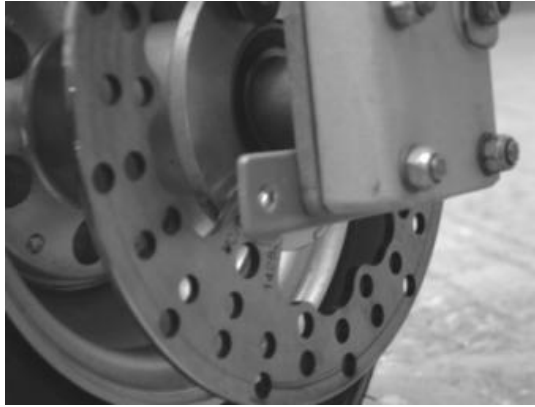


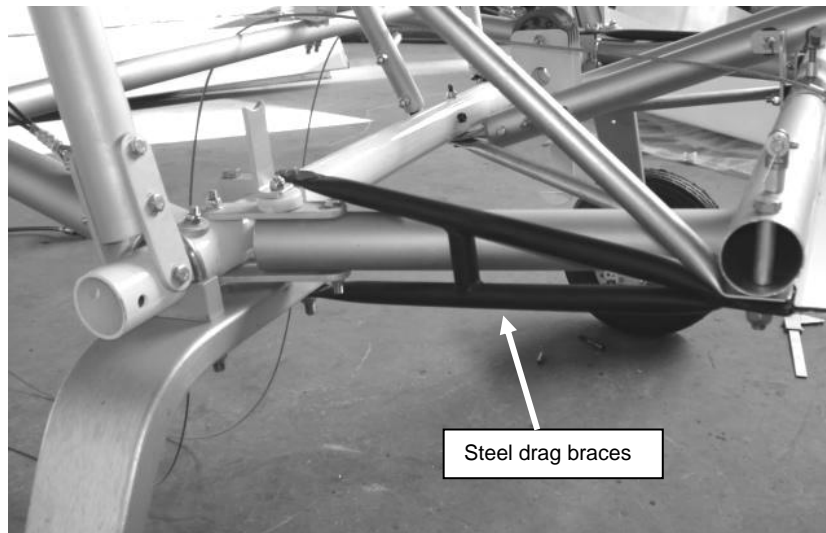
Figure 79 Nynja undercarrige leg



**Figure 80 main gear inner spat mount.**

- c) Fit the undercarriage legs to the main undercarriage cross-beam **SKR9**

*Make sure that the legs are on the correct sides to place the brake callipers towards the rear!*



**Figure 81 main gear leg mounting.**

- d) The outer clamp should be positioned as far outboard as possible, against or close to the plates holding the base of the rear cabin uprights **SKR6**. Don't fully tighten yet.

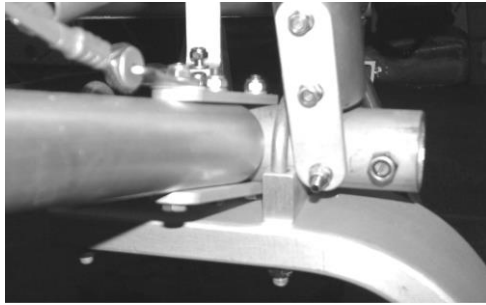


Figure 82 outer U-clamp position.

- e) Fit the steel drag braces (Fig 80), and then tighten all attachment bolts.

*The forward end attaches under the SKR144 triangulation side tube (which should be fitted at this time assemble as per Figure 80). Ensure the attachment bolt does up tight without becoming thread-bound, It may be necessary to add another washer under the nut to achieve this balance. Bolts should be fitted head down as shown. Note the bolt that attached the SKR144 is longer than the rear bolt – check they are correctly orientated so.*

*The lower rear end goes under the gear leg and the upper rear end goes over the top of the upper clamping block. Ensure the front attachment bolt does up tight without becoming thread-bound, but also has no thread bearing on the drag brace. It may be necessary to adjust with washers under the nut to achieve this balance.*

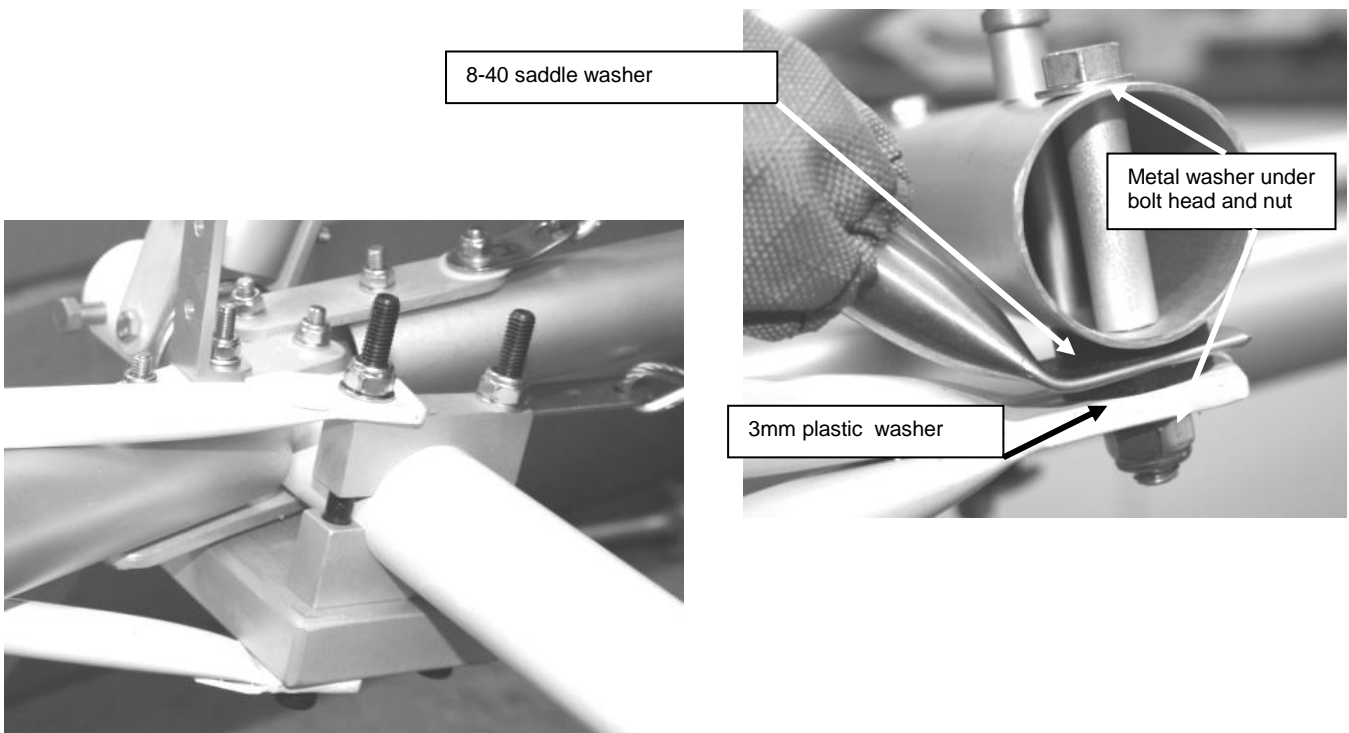
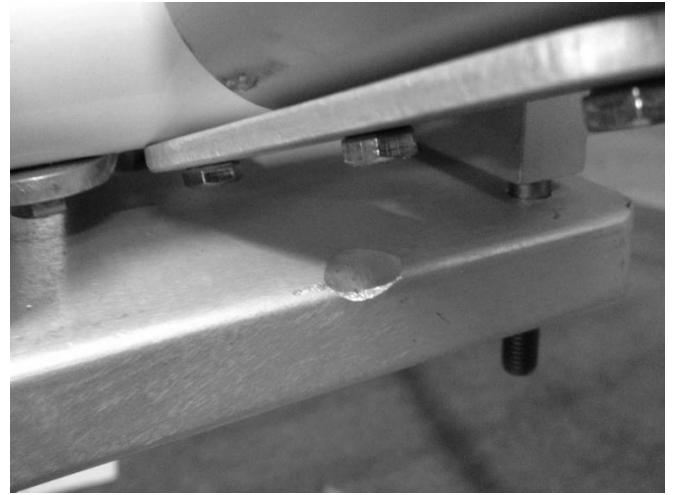
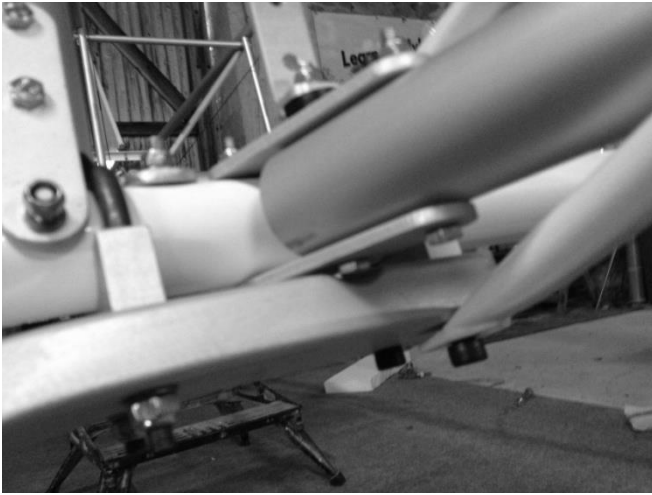


Figure 83 rear and forward ends of starboard drag brace





**Figure 84 interference cure**

You may experience interference between the undercarriage leg and the bolt head as shown. If so file a rebate in the undercarriage leg as required. Make sure edges are smooth and protect the bare metal with some paint or laquer.

### **4.3 Nose Gear**

Refer to Figure 85.

- a) If no spats are to be fitted apply grease to the inside of the nose wheel lower and upper guides. If spats are to be fitted, then leave this until the nose leg is removed to fit the spat.

*This is to minimise the risk of contaminating the rubber washers with grease. It is best to leave fitting the spats until the end of the build, otherwise they are likely to suffer damage during the rest of the build (yes you will drop that hammer on it!).*

- b) Slide the nose leg up through the lower guide.
- c) Put a large steel washer, then 7 rubber washers, then another large steel washer, onto the nose leg before sliding it up through the upper mount.

*Washers and axle parts may be packed separately marked '88'.*

*Check the number of rubber washers supplied, you may receive an extra one or two. Use only the specified number.*

*It is important that the nose leg should be free to swivel in its guides with little or no perceptible friction.*

*If the nose leg is stiff to turn due to a slight misalignment between the upper and lower brackets try turning it around 180°.*

*If the nose leg still does not easily align with the upper bracket in a side-to-side manner, slide it clear of the upper bracket and gently apply a tweak to the lower mount using the nose leg itself as a lever. The aim is to achieve good alignment to remove any friction in the rudder controls. If a small tweak does not suffice, the holes securing the lower guide may be elongated slightly, parallel with the nose leg. Do not*

elongate them in any other direction, as this will introduce slop into the position of the lower guide.

If the nose leg is still stiff to turn, smooth any protruding weld inside the upper and lower mounts with abrasives. A small file or a flap wheel can be useful.

Do not get oil or grease onto the rubber or metal washers, as this may cause them to slip over each other in a very heavy landing. This can result in the rudder control circuit feeling stiff or binding, due to misalignment of the nose wheel steering bar.

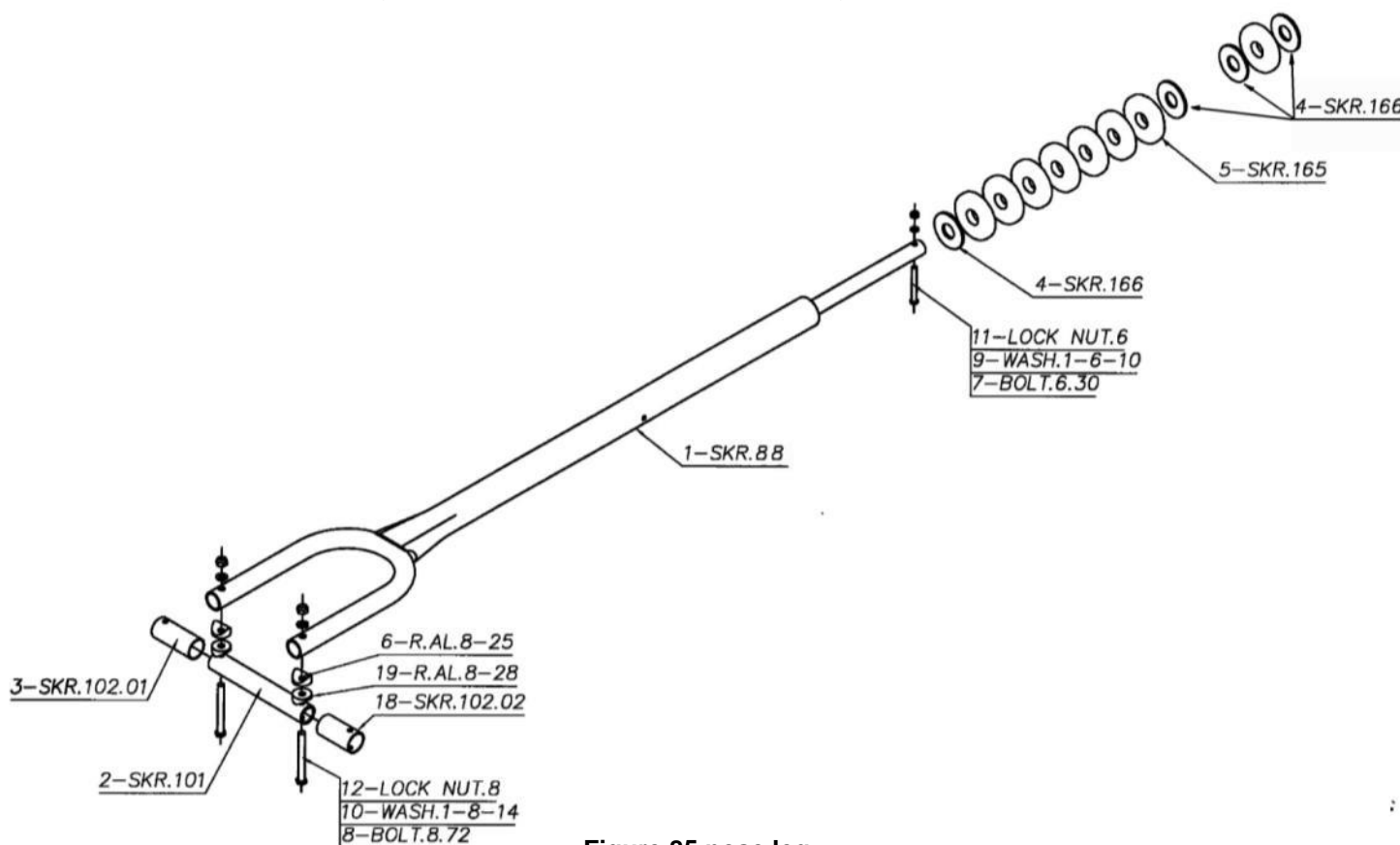


Figure 85 nose leg

- d) Above the upper mount there should be another two large steel washers with one, two, or three rubber washers between them as required, secured by a bolt through the nose-leg.

*If a nice fit without excessive vertical play cannot be achieved, make a sleeve to go over the top of the nose-leg, and drill it for the securing bolt at the required position to hold the nose-leg firmly in place. Ensure that the fitting is not squeezing the rubbers, as this will increase friction. A little vertical play is no problem and better than an overly tight fit.*

- e) Ensure that the lower engine mount triangulation tubes passing either side of the nose leg do not touch it.

*Use additional washers to space out the lower ends of the triangulation tubes if necessary.*

### 4.3.1 Nose wheel

- a) Assemble the wheel on its axle **SKR101** with a spacer tube **SKR102** on each side figure 85.

*The spacer tubes are cut to different lengths to centre the wheel on the axle, as the wheel is not symmetrical about the hub.*

- b) The axle should be attached behind and below the forks.

*Check that the tyre does not rub against the side of the forks. The fit can be adjusted by filing the holes in the spacer tubes so that the wheel can be moved sideways. Once in a perfect central fit, tightening the attachment bolts will lock it into place.*

### 4.3.2 Nose wheel steering

- a) The nose leg fits to the steering bar between the two 90 degree brackets.

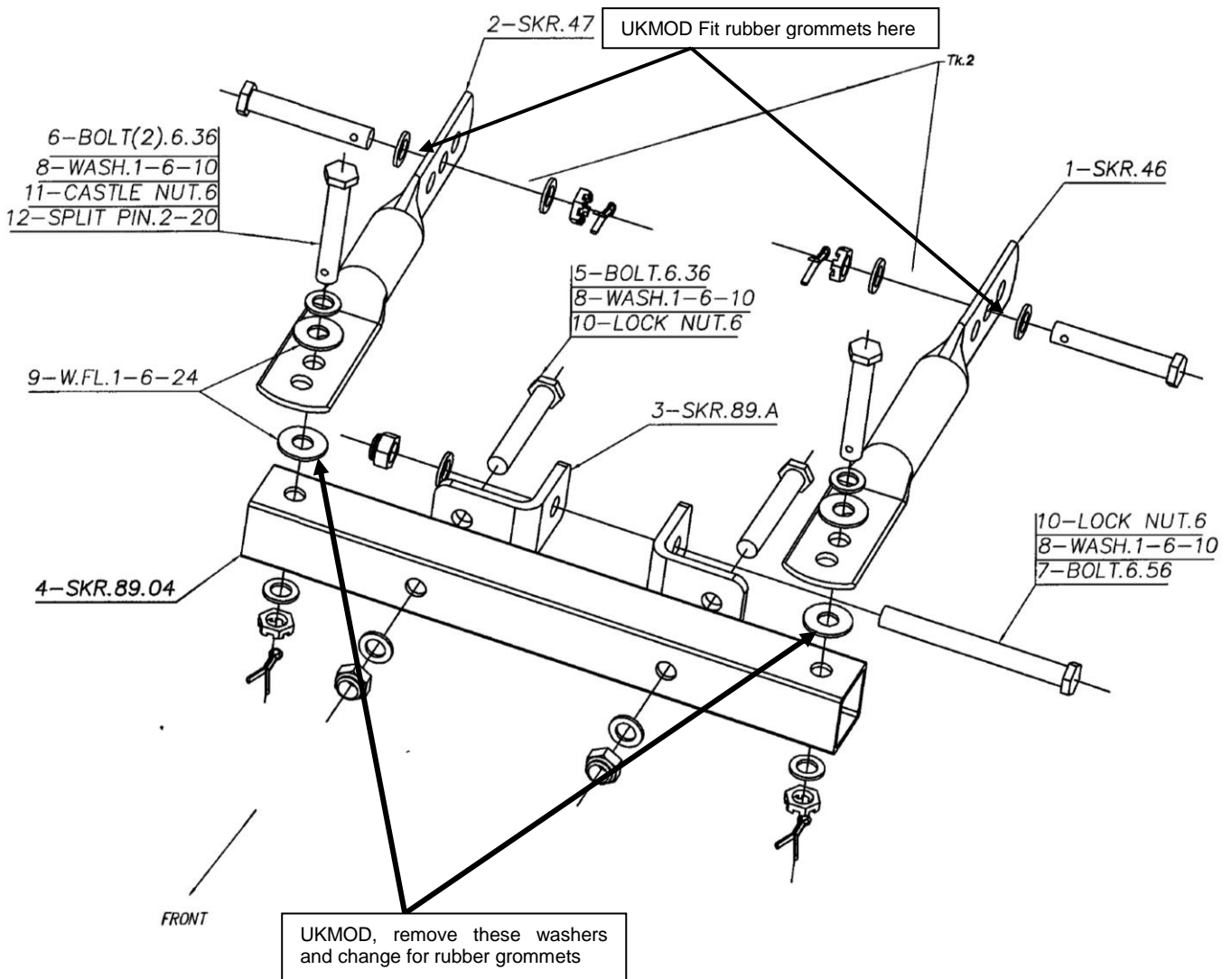


Figure 86 Nose wheel steering.

- b) Temporarily fit the two small steel pushrods **SKR44** and **SKR45** linking the steering bar to the rudder pedals. Use the middle holes at this stage.

*One pushrod is longer than the other to account for the offset of the rudder pedal pivot bars.*

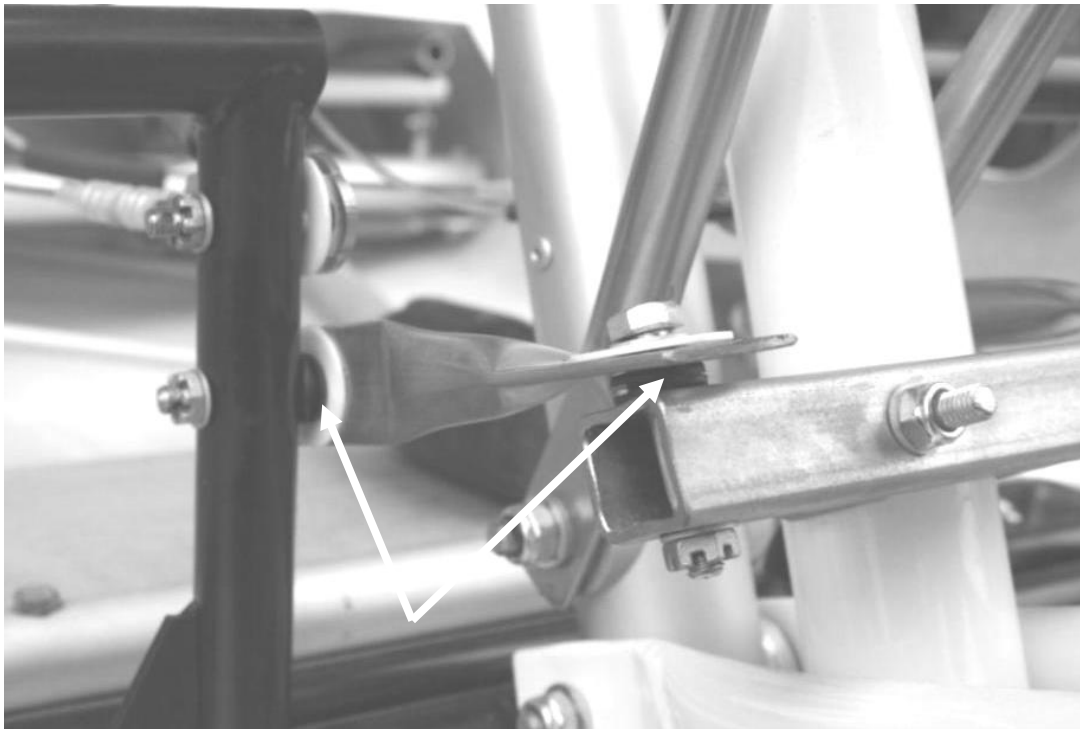
- c) UKMOD: Rubber grommets must be fitted between the box section and steering pushrods and between the pushrods and the pedals to facilitate angle change at steering extremes.

*Ensure that you have fitted these, as otherwise the steering will not operate properly.*

*Make sure all the other metal and plastic washers are removed. Fit one of the plastic washers supplied in the bag with the grommets under each bolt head*

*Do not tighten the bolts so much that you completely squash the rubber grommets!*

- d) Temporarily fit the pushrods to the rudder pedals, using the middle holes on the pushrods and the second hole from the top of the pedals.
- e) Pedals may be adjusted rearwards by using one or both of the outer holes in the pushrod. However using the inner holes to move pedals forwards is not recommended as it can cause fouling with the rudder stop cables which are fitted later.
- f) Note the bolts used at both ends of the pushrods should be fitted with split-pins once adjustments are finalised.



**Figure 87 nose wheel steering bar, with rubber grommets between pushrods and box section and pushrods and rudder pedals, note the white plastic washers shown near the arrows should not be fitted.**

## 4.4 Brakes

### 4.4.1 Brake brackets

- a) Slide the main wheels into place on the stub-axles. Use a smear of grease.

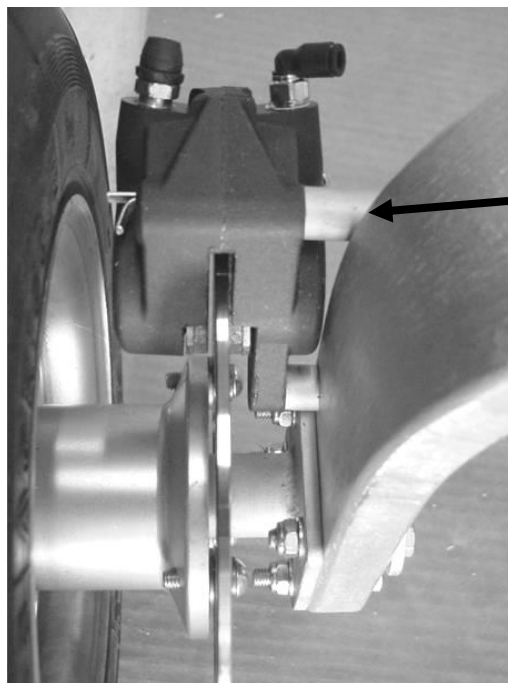
*Sometimes the wheels are a tight fit on the stub axles. If the wheel cannot be slid on and off easily use some fine glass-paper and smooth the exterior of the stub axle, then assemble with a little grease.*

- b) Slide the callipers over the brake discs, Figure 89

*The callipers must be handed to sit behind the undercarriage legs by swapping the bolt which holds the calliper halves together to the other hole on one of the callipers.*



**Figure 88 brake calliper mounting.** Note bolts are usually the other way round, heads towards the wheel which keeps the threads away from the axle flange.



Make sure spacer / bolt sits against gear leg like this.

**Figure 89 spacers on brake mounts.**

- c) Bolt the callipers to the undercarriage legs, using spacers as required to centre the callipers on the discs, Figure 89

*The parts to mount the callipers are in the UK Mods kits, but the stainless straps may be in the A9 bag.*

*Note there is movement of the wheel available, but the position used should be with the wheel as close to the undercarriage leg as possible.*

*If the hole through the undercarriage leg is not square, the calliper will not sit correctly. Open out the hole diameter a little to allow the calliper to find its own alignment.*

*Adjust / shim the spacers as required to ensure calliper is centred on and in alignment with the disc*

- d) Fix the wheels in place with lengths of aluminium tube **SKR111** slipped over the axle and drilled to allow a bolt to secure them to the axle.

*If spats are to be fitted, fit the 80mm extension tube from the spat kit. See spat fitting section for fitting details*

#### 4.4.2 Hydraulics

- a) Mount the brake lever on the front of the control stick.
- b) If the brake lever fouls the instrument panel, when this is fitted, it will be necessary to put a small stop in front of the lever to limit its forward movement.

*This may be a small bolt, chopped off and screwed into place, or some other chocking device. An alternative is to saw off the end of the brake lever to remove the 'bobble'.*

- c) Use Teflon tape or an appropriate thread sealant on the threads of the end fittings at the callipers and the brake lever, to help seal the fittings to the callipers and lever.

*The threads on the bleed nipples themselves are best fitted with loctite and will need to be done up fairly tight to seal.*

- d) Assemble the hydraulic tubes from each brake to the brake handle.

*Systems may be supplied with a 'Y' splitter on the brake handle outlet, or a separate T piece that may be positioned behind the SKR15 or in front of the SKR9*

*Cut the ends of the hydraulic pipe squarely and cleanly.*

*The connectors are a firm push-fit on the tubes. Give the tubes a tug to check they are seated properly.*

*Leave a little slack to allow for movement of the control stick.*

*Check that there are no high points between the brakes and the lever, as this could trap air bubbles and give a spongy feel to the brakes.*

- e) Bleed the brake system until the brakes become effective at preventing the plane being pushed. The lever does not have to be very hard to achieve this.

***Ensure that no brake fluid is spilt on anything. If any is spilt, wash off with copious amounts of water. Use containers / oven trays etc. to catch any fluid dripping off the reservoir or running down the stick. Beware of spurts of fluid out of the reservoir filler or the bleed nipples.***

*Fill the system from the bottom up through the calliper bleed nipples, using the syringe supplied or a pressurised bottle available from Halfords or similar. This seems the most reliable method and should be used. To get firm brakes it will be necessary to push enough fluid upwards in one go to fill the calliper and the brake lines and flood fluid out of the master cylinder (use plenty of rags and a catch tray to prevent fluid spilling on the airframe). A 'stop start' approach will result in bubbles of air being trapped.*



**Figure 90 brake bleeding**

- f) If the brakes leak fluid they will require more sealant tape on the threads.

*It may appear that the brake callipers are leaking from the seal between the two halves. This is unlikely to be the case: typically some fluid from a leak on the bleed nipple gets between the calliper halves, and can then be seen as a line when the brakes are squeezed and the callipers flex slightly.*

*The hydraulic fittings on the brake callipers may need to be tightened up quite a lot to prevent weeping of fluid.*

Run-in the brakes on the ground before flight testing commences.

## 5. Tail Surfaces

### 5.1 Tensioning the Rear Fuselage

- a) Ensure that the front of the vertical fin is not yet fixed to its mount.
- b) Check that the rear fuselage is sitting approximately squarely, then tighten the bolts around the rear fuselage, remembering to use threadlock.

*If there is some “set” in the rear fuselage, get a helper to twist it straight whilst you do the bolts up. This will help when the cables are used to correct the “set” as detailed below.*

- c) Ensure the fuselage sets at the right vertical alignment.

*This is done by tensioning the turnbuckles on the C cables individually. Sighting between SKR14 forward cabin tube and fin whilst standing ahead of aircraft will confirm vertical alignment. If turnbuckle tension required is significantly asymmetric then shortening the length of the D cable on the opposite side to the turnbuckle that requires the greatest tension will help. To do this slacken the turnbuckles and undo one end of the D cable to make the twists, replace and re-tension turnbuckles.*

- d) Final tension of C cables should be around 5Kg for a 10mm displacement when cable is pulled at right angles downwards and mid cable length point, using a travel scale or similar

*A and B cables should not be loose but don't need great tension.*

- e) E and F cables should have light to firm tension. Their tension has an influence over curve in the vertical plane of the fuselage longeron tube – TU2 and 4's. Asymmetric tension may pull the fin out of vertical. If required adjust tension so all is straight by winding or unwinding the cable, and reattaching. A helper is useful to apply pressure to the frame to help reattaching.
- f) When tensioning it is possible that you may remove and refit the lower wire attachment bolt on the central frame. **Make sure that the bolt passes through the eyebolt fitting and does not pass alongside leaving the structure insecure.**
- g) Finally secure all cables where they cross with a small length of split thin wall tubing (the pitot tubing can be used) over one cable, and a cable tie.



Figure 91 securing crossing cables, and check for incorrect fixing of lower central frame.



## 5.2 Elevator Trim Tab

The action is transmitted from the trim lever via a Bowden cable to the trim tab, reacted by a pair of springs. The mechanism will be fitted later

### 5.2.1 Elevator trim tab

- a) If desired paint the elevator trim tab hinge

*The hinge is steel and being downwind of the exhaust outlet can be subject to corrosion. Painting or keeping it greased will ensure longevity.*

- b) Tap the elevator trim tab hinge pin out about 10mm, and cut this off. Tap the pin back into place.
- c) Drill a tiny hole, lockwire size, at each end of the hinge, either side of the hinge pin but not through the hinge pin.
- d) Wirelock these holes, to prevent any chance of the hinge pin falling out as it wears over time.
- e) If not already done, rivet the elevator trim tab hinge to the trim tab.
- f) Rivet the trim tab to the lower side of the trailing edge of the starboard elevator half, Figure 92.

*Elevator halves are handed, choose the correct one to place the slots for the eyebolt nuts to the underside.*

*Align the tapered part of the trim tab with the tapered part of the elevator.*

*Use between five and ten 3.2mm diameter steel rivets, rather than anything larger due to the small diameter of the trailing edge tube. Drill the underside of the elevator trailing edge.*

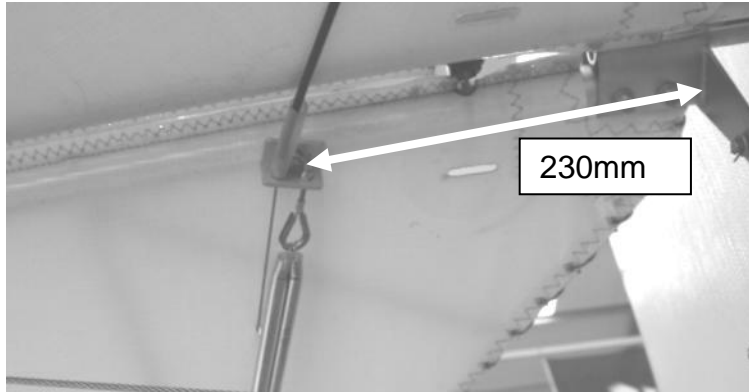
*If desired, leave the actual riveting on of the tab until the elevator halves are mounted on the aircraft, to keep the tab out of the way. However, it is worth drilling all the holes at this stage.*



Figure 92 trim tab and horns position.

- g) Attach the rear cable bracket to the lower forward edge of the elevator leading edge spar.

*Drill the 5mm diameter hole, vertical in relation to the elevator, 230mm from the inboard end of the elevator leading edge*



**Figure 93 trimmer rear cable bracket.**

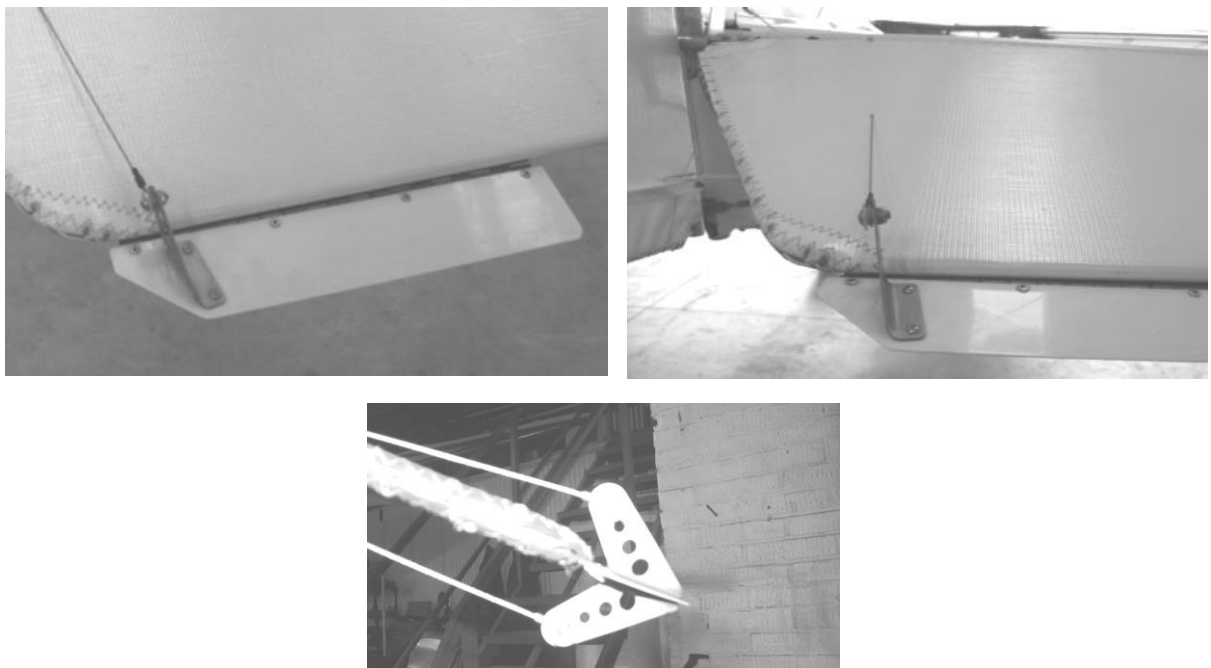
- h) Attach the control horns to the trim tab.

*The horns should be towards the inboard end of the tab, with the flanges for bolting to the tab towards the outboard end.*

*They should be positioned in the vicinity of the inboard end of the straight section of the tab trailing edge as per the photographs.*

*Align the horns to point at the rear cable bracket, and to place the cable attachment holes at the ends of the horn in line with, and erring towards slightly in front of, the trim tab hinge.*

*Use two short 4mm diameter bolts, cut down to length if necessary.*



**Figure 94 Trim tab horns aligned with cable bracket and hinge pin**

## 5.3 Tailplane

The tailplane and elevators are assembled and trial fitted at this stage, and then removed to fit the fuselage fairings.

### 5.3.1 Horizontal stabiliser

- a) Select the four short cables, which brace the tail surfaces.



Figure 95 tail surfaces and bracing cables.

- b) Attach the upper cables to the back of the vertical stabiliser.

*These are the cables without turnbuckles. Mount the horizontal stabilisers to the forward and rear mounts on the rear fuselage,*

- c) Fig 97

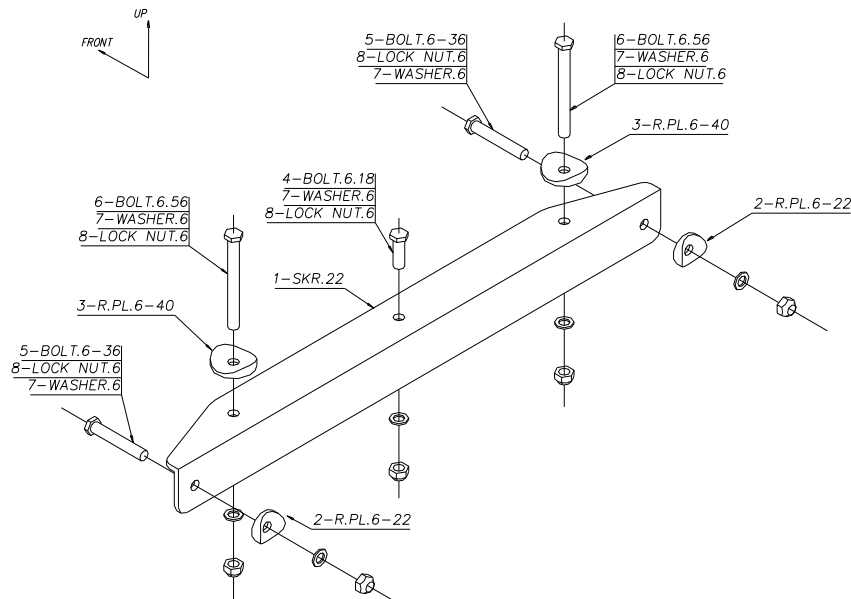
*The nut securing the front of the tailplane halves may be tight against the structure of the tailplane. If so, hold it flat against the structure and turn the bolt to tighten it up.*

*If it is still too close for this to work, try loosening the lacing holding the fabric as this may allow the tubes to spring out of the way.*

*The forward mounting should be left fairly loose to allow the halves to pivot, and will have to be undone later when the fuselage fairings are fitted, so do not threadlock it at this stage.*



Figure 96 horizontal stabiliser rear mountings.



**Figure 97 vertical and horizontal stabiliser front mounting.**

- d) Attach the lower and upper cables to the back edge of the horizontal stabilisers at the outer eyebolt.

*The upper cables should go on first, against the tailplane trailing edge tube - do not fit saddle or flat washers under them.*

*The turnbuckles should be at the inboard, lower ends of the lower cables, where they can be attached to the tangs already fitted to the lower rudder eyebolt. Tighten evenly by hand. All four eyebolts along the trailing edge of the tailplane halves should all line up when sighted through.*

*Generally to achieve alignment the inner eyebolts on the horizontal stabilizer have a saddle washer and one 3mm plastic spacer behind them, to match the spacing of the outer eyebolts where the bracing cable tangs attach. There are no saddle washers used on the outer eyebolts.*

*The trick of using either sticky tape or blue-tack to hold washers and nuts to spanners is worth remembering here. Alternatively Maplins sell forceps which can be very useful for this.*

### 5.3.2 Elevators

- a) Put the port elevator into place and secure with a pivot-pin through each eyebolt.

*As the elevator is likely to be removed for transportation etc., the pivot-pins should not be split-pinned at this stage.*

- b) Slide the joiner into place onto the port elevator and then fit the starboard elevator.  
 c) Make sure that the joiner is fully pressed back onto the elevator tubes and fits snugly.

- d) Align the elevators with the tailplane, using two wing under-surface battens or similar straight edge and some bungee cord to hold them level, Figure 98.



Figure 98 elevator joiner and alignment (note: Skyranger joiner shown – Nynja version has integral elevator horn).

**e) Make a final check of alignment!**

- f) Ensure that the holes in the elevator joiner are perpendicular (90 degrees) to the elevator halves so that the joiner is properly centred, then using the joiner as a jig drill through the tube in the following sequence.
- g) Drill the top side first then underside.
- h) Do one hole first in one elevator half, and pop in a bolt.
- i) Recheck the alignment!**
- j) Next drill a hole on the other elevator half, and again pop in a bolt.
- k) Do another, very final check of alignment and then drill the remaining two holes, one in each elevator half.
- l) Tighten the bolts



Figure 99 drilling the elevator halves.



Ensure joiner sits so holes are drilled perpendicular to elevator centerline !

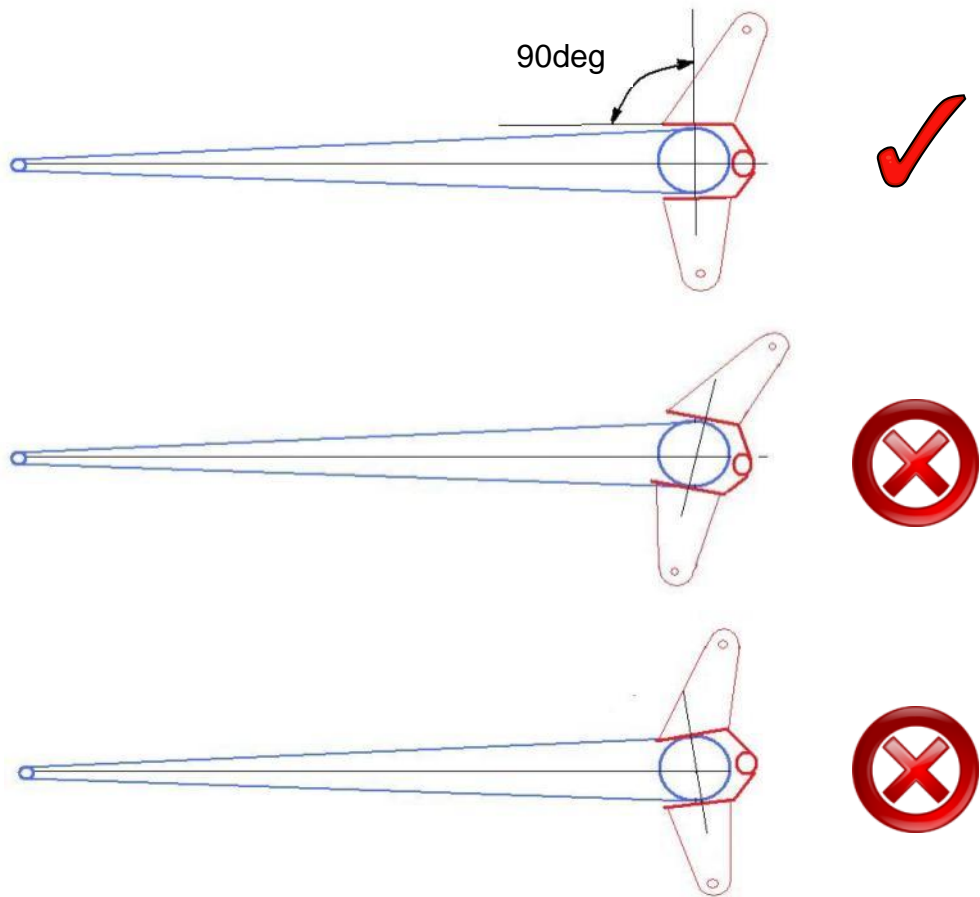


Figure 100 Nynja elevator joiner with integral control horn

## 5.4 Rudder

### 5.4.1 Rudder horn assembly

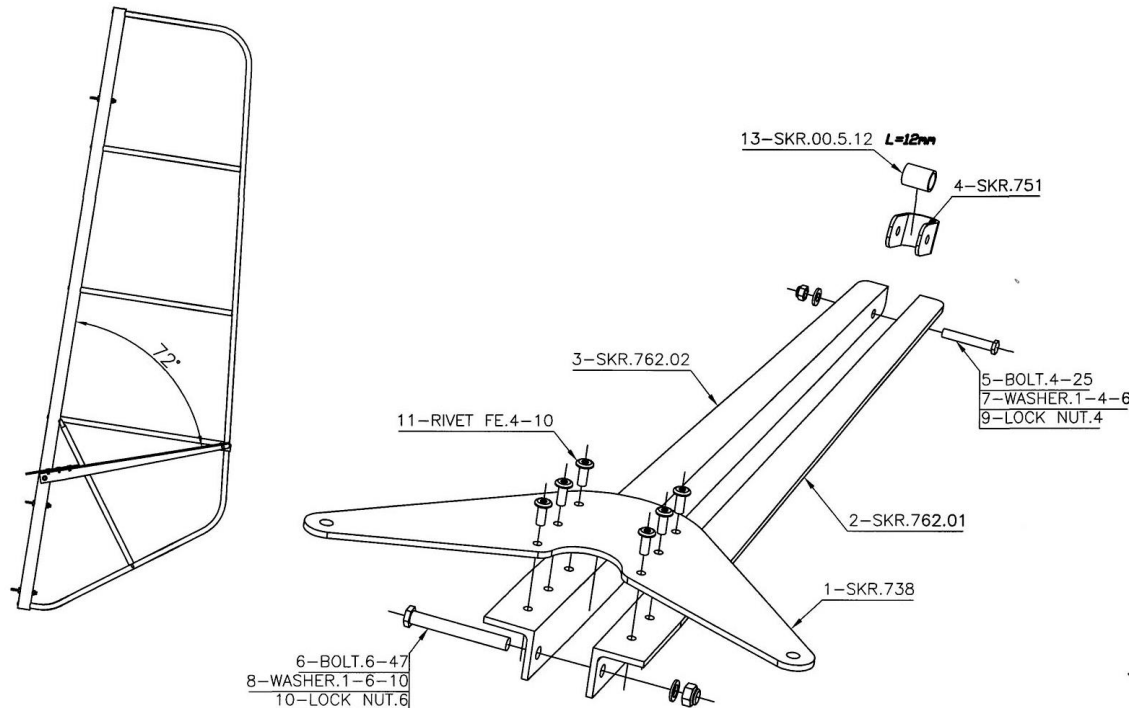


Figure 101 rudder horn assembly (note: Skyranger rudder frame shown. Nynja Rudder is slightly different shape).

- Remove the fabric over the 6mm holes in the rudder leading edge spar with a soldering iron.

*These holes can be felt through the covering,*

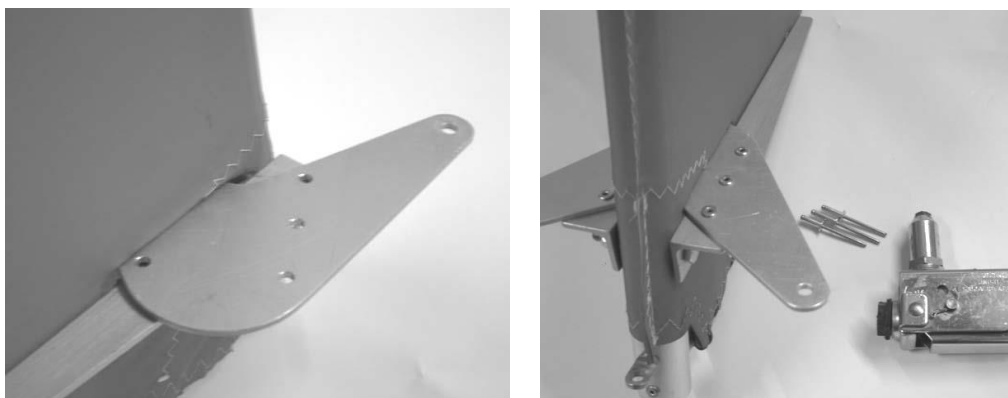
*Put in place the bracing angles and secure them lightly with a 6mm diameter, 35mm plain shank length bolt through the hole.*

- Position the angles so that the rear 4mm hole is just in front of the rear tube, and just below the horizontal bracing tube.

*This will be on the trailing edge of the rudder.*

- Burn a hole both sides of the fabric to accept the 4mm securing bolt.
- Bolt this end together complete with the sheet U-brace between the aluminium braces and the rudder covering.
- Temporarily tighten the 4mm rear bolt and the 6mm front bolt.
- Take the soldering iron and burn a slot in the fabric above the braces to accept the rudder horn.

*These slots should extend back approximately 80mm measured from the centre of the tube. Use the edge of the braces as a guide and keep the slots tight to their edges, Figure 102.*



**Figure 102 rudder horn fixing.**

- g) Next insert the horn into position and check the alignment of the rivet holes.
- h) Ease the holes with a 4mm drill or reamer if necessary to ensure all rivets fit.

*Check for excessive tightness or looseness of the securing bolts if alignment is not easy.*

*If the holes are well out, it may be necessary to file away some material from the central part of the horn, where it presses against the rudder leading edge tube, to allow it to be positioned slightly further forwards.*

- i) Rivet the horn in position with 4mm diameter **steel** rivets.

*Take care to ensure that the head of the rivet gun is flat in relation to the horn. If your gun is too wide the fabric will prevent this and the rivets will not seat correctly – get a narrower gun if this is the case.*

- j) Finally tighten the bolts, remembering to use a small dab of threadlock. Don't get it on the covering!



**Figure 103 Nynja rudder (note: trim tab not required)**



## 5.4.2 Mounting the rudder

- a) Attach the vertical stabiliser front mounting. It will need spacing from the SKR22 angle so that when tensioning the bolt it doesn't pull downwards. There are some plastic bobbins in the A9 bag that can be used for this plus plastic spacer washers as required.
- b) Attach the rudder to the vertical stabilizer using the three eyebolts

*The eyebolts fitted to the rudder itself should have two steel washers under their heads to stand off the rudder a little or may come with aluminium saddle washers. **Plastic saddle washers should not be used in this position.***



**Figure 104 rudder mounting – top middle and lower hinge**

- c) Make sure that the rudder is not touching the stainless-steel elevator joiner tube when it is deflected from side to side ( $\pm 25^\circ$  or so) and the elevators are moved up and down ( $\pm 25^\circ$  or so).

*If it is touching you will need to put an additional steel washer under the eyebolts on the rudder to act as spacers – but ensure that thread still protrudes through the nuts..*

- d) Make sure the fit of the eyebolts is easy and the rudder can be deflected with no discernible friction.

*If the fit is tight and friction is present then the eyebolts need to be aligned. For up and down alignment do this by removing eyebolts from the rudder and filing the holes a little as required to bring them into alignment. For vertical alignment washer may have to be added under the heads of one or two of the eyebolts. When the rudder is finally fitted later assemble with grease which will further provide free movement and protect these steel parts against wear and corrosion.*

## 5.5 Control Cables

### 5.5.1 Cables

Identify the rudder and elevator cable pairs.

*The rudder cables are longer than the elevator cables and are not fitted with turnbuckles, but are fitted with long tangs with a number of mounting holes.*

*The elevator cables are fitted with turnbuckles, one cable has the turnbuckle at the rear end and the other has it in the middle, both forward ends have tangs with a single mounting hole..*

*Note that the cables will have to be disconnected later when the covering is fitted, so do not bend the split-pins over at this stage.*

**WARNING!** – when fitting the cables do not have the battery installed. Otherwise there is a risk that the cables may make a connection across the terminals and melt the cable or set fire to the aircraft!

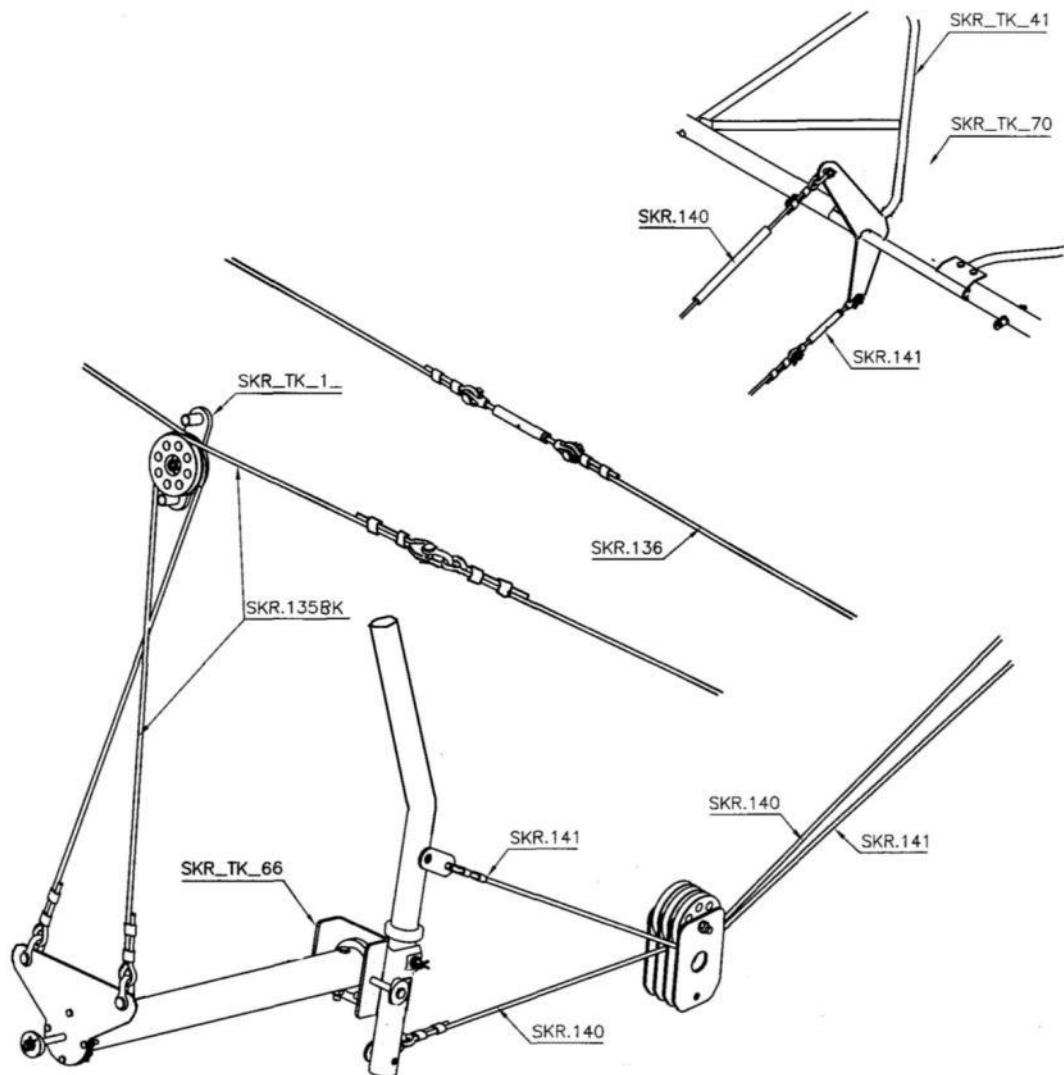


Figure 105 Elevator cable schematic

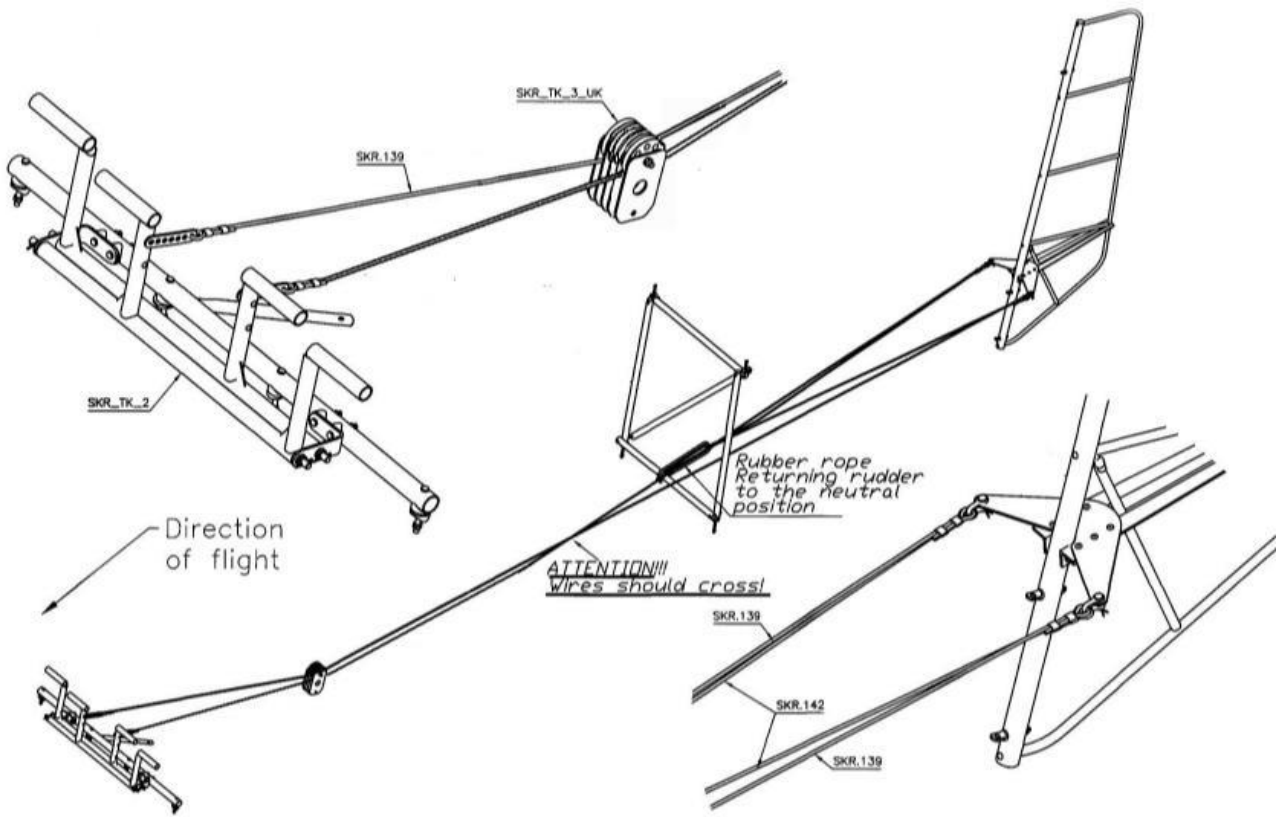


Figure 106 Rudder cable schematic

### 5.5.2 Pulleys

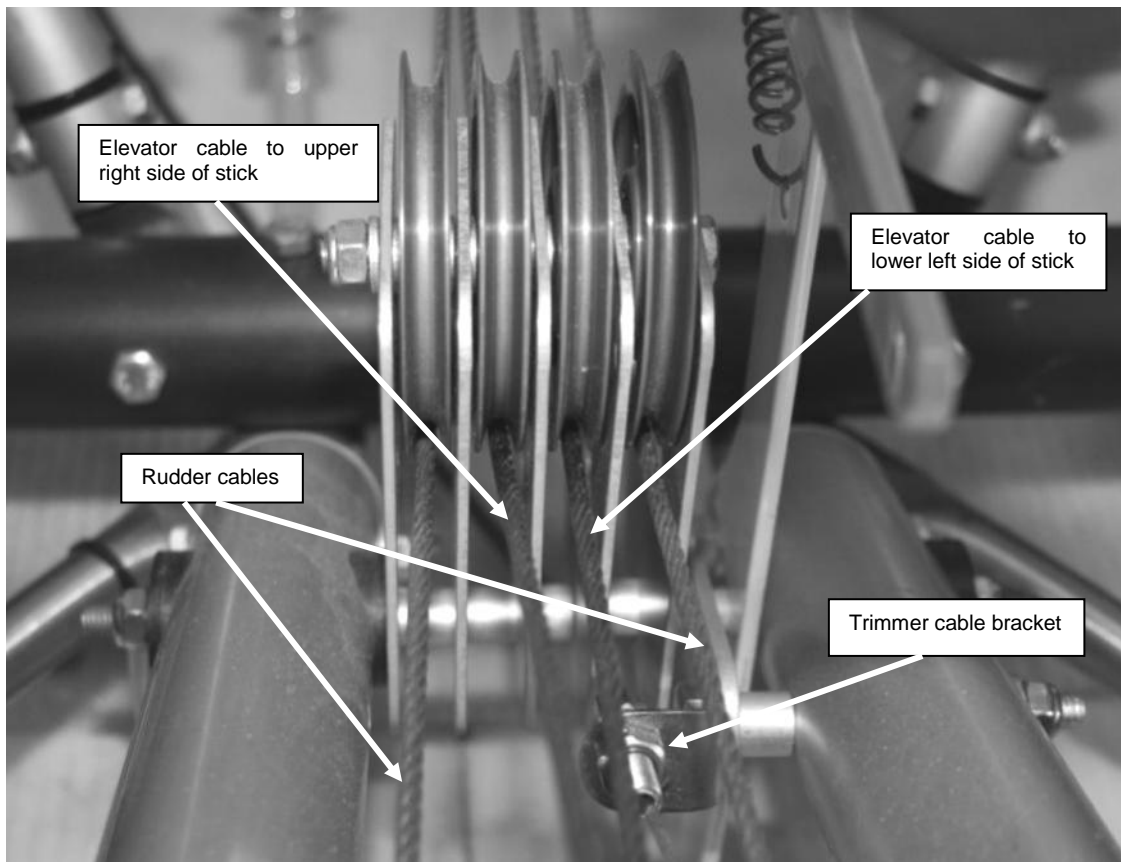


Figure 107 Nynja central pulley block arrangement loking rearwards

- a) Assemble the 4 pulley Block as shown in Figure 107 above. Note that the starboard most plate just has a saddle washer and 3mm spacer washer between it and the TU19. Space as required to eliminate lateral movement with washers on the port side of the port most pulley plate.

Pass through the control cables as shown in Figure 107. Rudder cables are not handed. The tangs with lots of holes connect to the rudder pedals.

*The elevator cable with a turnbuckle at one end should be fitted with the turnbuckle end to the rear and the front end to the upper attachment hole on the control stick. The other elevator cable has a turnbuckle mid length and fits to the upper end of the elevator horn and lower attachment hole on the stick.*

*Check that - A single metal washer should be in position on both sides of each pulley to provide a small amount of clearance from the side plate, not more than 1mm. A spacer tube should be in position on the pivot bolt to keep the side plates parallel.*

*Don't forget the flap detent lever retaining plate and its spacer tubes. The trimmer cable bracket attaches to the forward end of this and can be fitted at this time.*

*The control stick may have more than one set of cable attachment holes. If so the pair closest to the stick pivot should be used.*



**Figure 108 Nynja elevator cable connection on control stick. (Note: hole closest to pivot used, and that a thin plastic washer is fitted between tang and stick)**

- b) Tighten up the bolt passing through the pulley bearings
- c) Looking rearwards. The rudder cables are the lowest, with the elevator cables passing above them.



**Figure 109 cable routing past flap handle.**

*The cables pass close over the top of the tubes. Check the clearance with some tension in the controls, rather than just slack.*

*If the cables rub on the flap actuating rod, check that the lever is fitted as per the instructions, particularly on its position to starboard and the spacing of the detent lever. If this does not cure the problem, space the starboard spacer tube at the rear end of the flap handle out with washers and shorten the port spacer tube.*

- d) Check that the elevator deflects upward when you pull the stick back toward the rear of the aircraft.
- e) Tension the turnbuckles by hand, keeping the elevator central when the stick is at 90° to the cabin central tubes **tu19** (not vertically upwards).
- f) Check the elevator moves smoothly, without binding.

*It is not necessary to have a lot of tension in the cables.*

- g) Check that the rubber stop-rings on the joy stick act against the edges of the stick pivot, forming the control stops.

*When moving the stick forward or backward you should have around 25° of deflection in the elevator each way. If necessary, adjust this by filing the top and bottom edges of the stick pivot piece where the stop-rings bear. These are somewhat flexible, so set the deflection with some pressure on the stick.*

- h) Secure the stop-rings with adhesive such as epoxy or silicone.
- i) Attach the rudder cables to the pedals, using the stainless tangs that have several adjustment holes in them.

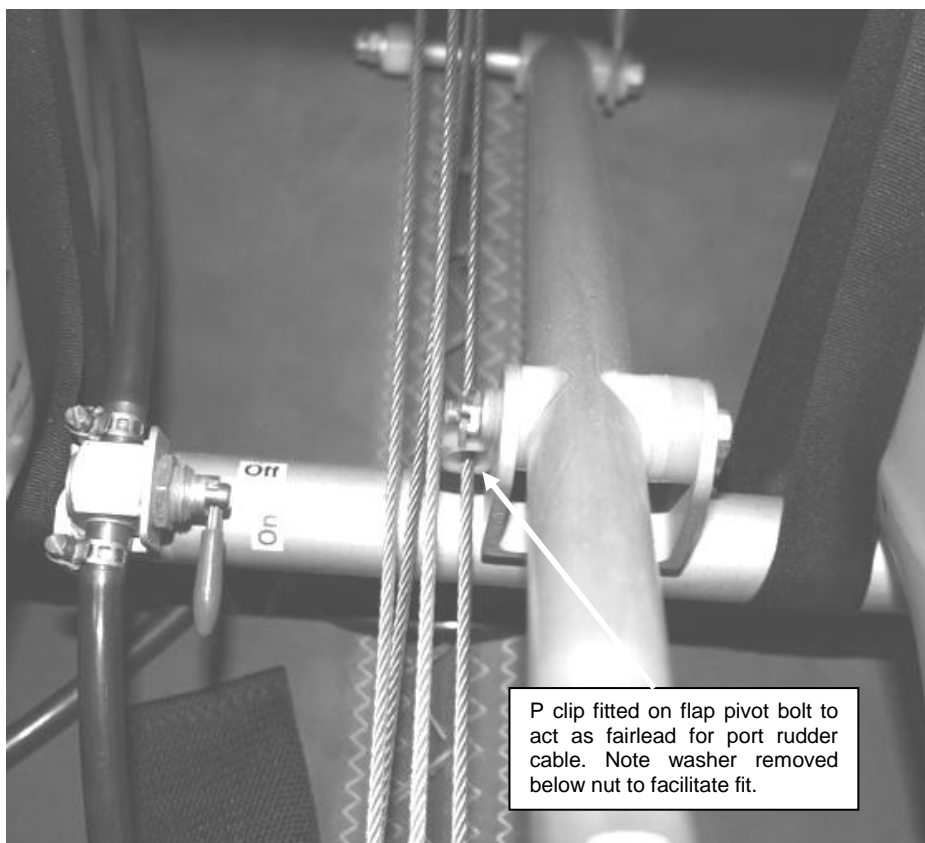
*The cable from the starboard-side pedal is the one which passes through the starboard-most pulley in the group of four. Note the cable routing for the starboard cable shown in Figure 115 which passes to the outside of the central brace angle.*

*Make sure the rudder cables pass over the flap handle mount and over the flap linkage at the rear end of the flap handle..*

*If they pass beneath the linkage the flap handle will push the cables downwards when you deflect the flaps.*

- j) Attach the rudder cables to the rudder horn, crossing them on the way back in the rear fuselage so that the starboard cable at the pedals attaches to the port rudder horn and vice-versa.

*Where the cables cross ensure the cable from the port side at the front is above the starboard cable. The port cable is then lifted up with the addition of a P clip fairlead as shown in Figure 110 below to help with clearance*



**Figure 110 Port rudder cable fairlead**

- k) Connect the rudder centring cables - a pair of steel cables connected together at one end, to the shackles on the rudder horn using the other ends

- l) Check to make sure that the rudder moves to the left when you push on the left pedals, and to the right when the right pedals are pushed.
- m) The tension in the rudder cables is adjusted using the selection of holes in the rudder cable attachment tangs.

*Try a range of combinations until you achieve a centred nose wheel and a centred rudder together, with just enough cable tension to remove any slack in the cables and prevent them lying against any tubes.*

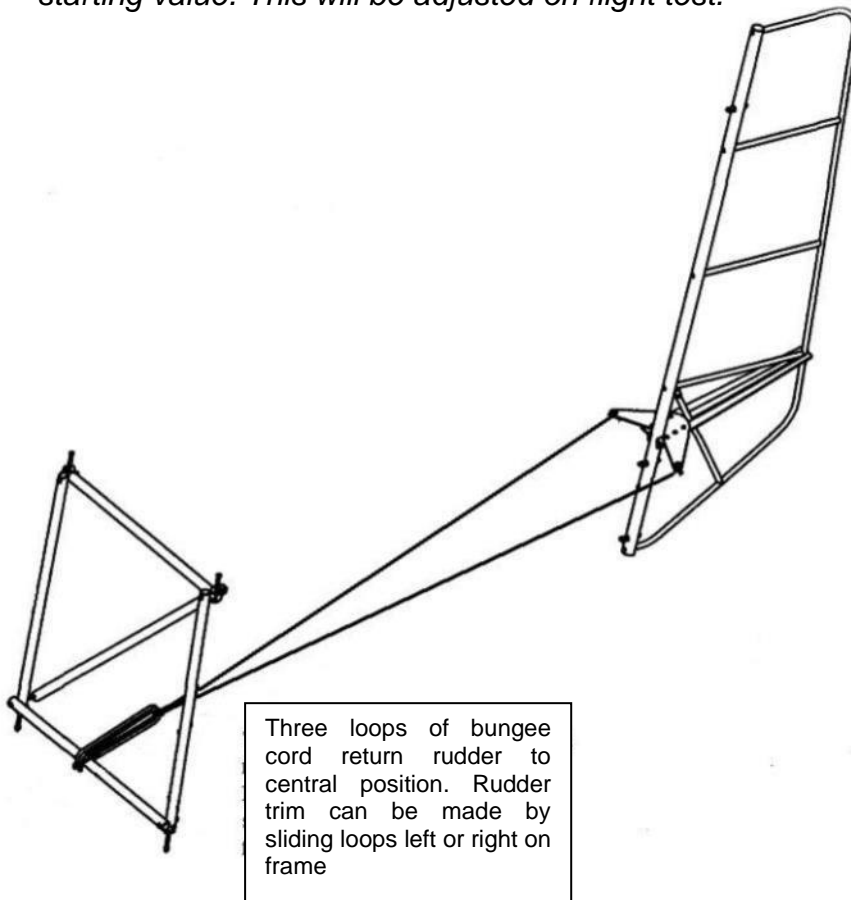
*The resulting positions are likely to be asymmetric due to the offset in the rudder pedal pivots.*

*Fine adjustments can be made by twisting up the cables in the same manner as was used for tensioning the rear fuselage.*

*The positions of the rudder pedals fore-and-aft can be adjusted together at this stage to bias the aircraft for tall or short pilots if desired. The seats can also be adjusted to suit.*

- n) Connect the bungee between the centring cable single end and the middle of the rear fuselage bracing frame.

*Use three loops of bungee around the tube. Offset the bungee by about 5cm to port of the centreline. Apply a gentle amount of tension, as a starting value. This will be adjusted on flight test.*



**Figure 111 rudder centering bungee arrangement**

### 5.5.3 Rudder stops

- a) Fit the rudder stop cables to the rudder pedals.

*The forward ends of the cables have a tang with a bend in it. This picks up on the same bolt as the rudder cable tang, fitted outside the rudder cable tang (closest to the centreline of the aircraft), with the bend angled towards the centre of the cockpit, Figure 112.*

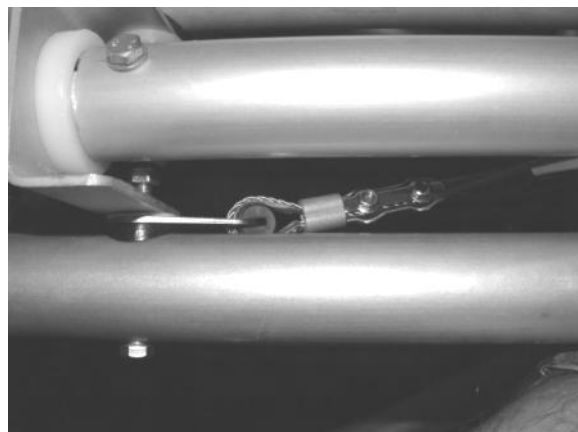


**Figure 112 rudder stop cable tang fitted over rudder cable tang.**

- b) The other end should be fitted to the bolts supporting the rear stick pivot, Figure 113, with the cables crossing: the cable fitted to port side pair of pedals should fit on the starboard side of the rear stick pivot, and vice-versa.

*A thin nylon washer should be placed between the tang and the rear stick pivot support, and a saddle washer between the tang and the central cabin tubes **SKR19**.*

*Note that they fit between the stick pivot support and the SKR19 tubes. They will have to be sprung apart to get them in.*



**Figure 113 rudder stop cables attached to rear stick pivot.**



- c) Ensure that rigging the rudder cables and setting up the correct tension/nose leg alignment etc. has been done before adjusting the rudder stop cables.
- d) Deflect the rudder until the required maximum deflection is achieved (see current HADS), and then adjust the stop cable to match.

*This is done by lightly clamping the cable with the stainless steel wire clamp supplied. Leave it loose enough so that the cable will slide through when the spare end is pulled firmly with pliers/grips. Pull the stop cable until it will go tight to match the rudder deflection. Ensure that the wire grip is slid up tight enough to push the cable ferrule against the cable thimble (the cable 'eye'), Figure 114.*



**Figure 114 rudder stop cable adjustment.**

- e) When happy with the adjustment, clamp up the wire grip to hold the correct position.

*Do not do this up too tight as it will distort the cable.*

- f) If you have access to a Nicopress swaging tool crimp the ferrule, remove the wire clamp and trim the excess cable. Use a hot air gun to shrink the piece of heat shrink supplied in position over the ferrule and cable end for neatness.

*If you could please return the clamps at your leisure they can be reused to keep costs to a minimum.*

- g) If you do not have access to a Nicopress swaging tool then remove the stop cables, send them back to us and we will crimp them for you.

*Leave the clamps in position so we will know where to crimp them! It's also a good idea to mark them so you know which side to refit them.*

- h) The bolt securing the rear tang can be done up tight, but do not crush the tube.
- i) The bolt on the pedal end should be loose enough to allow rotation as the pedal is deflected.
- j) Secure the middle of the stop cables with a short length of light Bungee looped over the control stick torque-tube just out of sight under the

instrument panel, to pull the cables up and prevent sag towards the battery.

#### 5.5.4 Rubbing cables

- a) Check both the rudder and elevator cables to make sure they are not rubbing on any tubes.

*Apply some typical tension to the cables, such as feet against the rudder pedals, as this will give a better indication of any problem areas.*

- b) Fine adjustments to the pulley positions can be made. The pulleys may have to be carefully shimmed with thin washers between the starboard central cabin tube **SKR19** and the first pulley plate to ensure that the rudder cable just avoids rubbing on the tube where it runs from the pedal to the pulley, figure 115.

*The cable should not quite touch the tube with weight on the rudder pedals. If it is too close for comfort a piece of prop tape can be placed on the tube to act as a fairlead. If it touches the starboard central cabin brace piece this may be shimmed out with plastic washers between it and the **SKR19** tube, up to 3mm if necessary. This limit is due to the elevator cable rubbing the central brace at full left aileron.*

*Any shimming of the pulleys must not be over-done or the elevator cable on the lower end of the stick will rub on the central cabin brace, attached to the port central cabin tube **SKR19**, on full right aileron. Wait until the aileron movements are set up later before worrying too much, you may have to adjust the stops to reduce the movement to the correct amount.*

*Adjustment of the cables and the pulleys will require some fiddling to achieve nice clean cable runs which do not rub, so don't tighten the bolts up until this is achieved.*



Figure 115 starboard rudder cable routing past central braces.

- c) Pieces of prop-tape or off-cuts of Lexan from the screen can be used to provide additional protection to the tubes if the cables only rattle against the tubes with vibration.

*They should not be relied on if the cables apply any constant pressure to any tubes they pass over.*

*The brace in the middle of the rear fuselage is a good place to apply such protection.*

- d) With the controls centred and the cables properly tensioned, including foot weight on the pedals, the elevator cables will be close to, but not touching, the rudder cables, and there should be 5mm or more between the rudder cables where they cross. With the rudder deflected the rudder cables may touch one another where they cross, but this is acceptable.

*The cables are supplied with lengths of heatshrink tubing on them. Place these where they will best protect the cables from the structure and vice versa, and then shrink in position using a heat gun.*

*The upper elevator cable also has a length of plastic tubing which will be positioned later to act as a fairlead where the elevator cable emerges from the fuselage fairing.*

### **5.5.5 Take the tail surfaces off again!**

- a) Once fit and action / deflections has been verified then remove the tailplane and elevator halves and rudder in preparation to fit the rear fairings.
- b) Carefully secure the control cables with cable ties as near to their correct positions as possible and such that they won't get in the way of fitting the fairings or become twisted, but are laid in good positions to pull through the exit holes in the fairings for reconnection later.

## 6 Fitting the Rear Fuselage Fairings

**Do not cover the fuselage until it has been inspected!**

See the inspection schedule in your BMAA paperwork.

Important: Before covering the fuselage, make sure the cables bracing the rear fuselage have been tightened and the turnbuckles have been safety wired and all bolts are done up and threadlocked. Particularly check for any plain nuts that might have been missed!

### 6.1 Preparing the rear fuselage fairings

- a) Before being fitted the composite fairing panels have to be handled with care and can be easily damaged. Four hands are required to move the fairings around, and care should be taken to protect them from being scratched and to support them appropriately when working on them off the aeroplane. Flexing them too far can result in surface cracking.
- b) The fairings are marked with cut lines where parts of the structure protrude such as the control cables, tailplane front mounting bracket and certain bolt heads. These should be carefully cut out prior to fitting the fairings to the fuselage. There may also be moulding flashings that need trimming and edges smoothed. Underneath at the rear is a 15cm diameter hole to permit access.
- c) A Dremel multi tool is recommended for these tasks and can be used with a cutting disc to open up the holes, and a sanding attachment to trim exactly to the cut lines. Some final hand or block sanding may be required for that perfect edge.

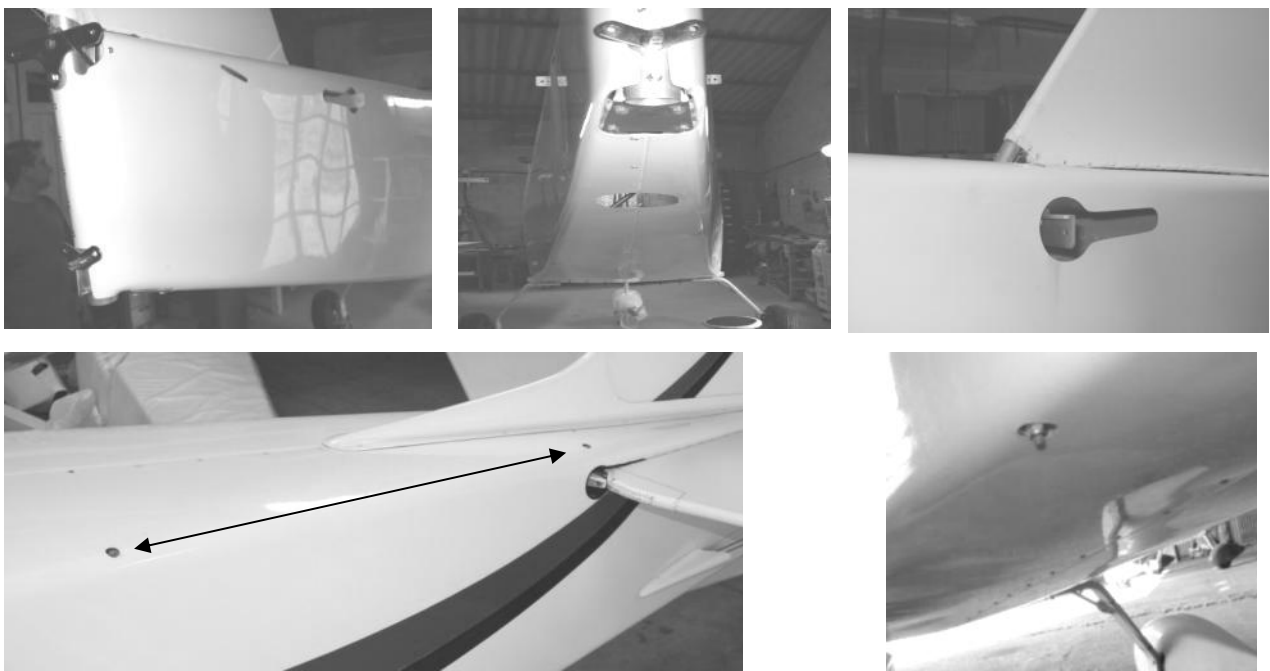


Figure 116 fairing cutouts

## 6.2 Fitting the rear fuselage fairings

- a) Prepare the fuselage longerons by covering the outside edges where the fairings will touch with clear tape – clear packaging tape is enough and will help prevent any damage from slight movement and abrasion in service. Also smooth any small lumps or sharp shards from the inside of the corners of the fairings with 80 grit or similar sandpaper.
- b) It is very important the following sequence for fitting is followed otherwise the fairings can be damaged:

*Fit the starboard (right) fairing first. Fit at an angle so that the lower edge is put in position first. Make sure the bolt from the central bracing frame fits in the hole in the fairing.*

*Then rotate so the upper edge 'clips' over the upper fuselage longeron.*

*Fit the portside in the same manner taking care to overlap the starboard fairing on the joins.*



Figure 117 fitting the rear fairings in position.

- c) Wrap some webbing straps around the fairings and tension to pull together.

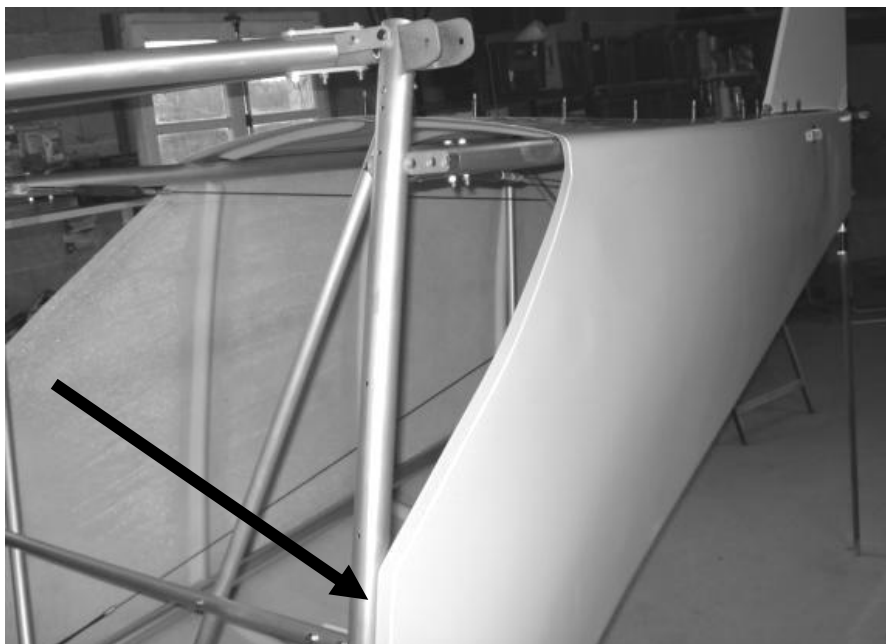
*Take care to do this gently and protect the fairings against any buckles or ratchet levers.*



**Figure 118 strapping**

- d) Verify correct positioning:

*The halves should line up together at the top front, and the front side edges should align with the rear cabin vertical TU6 tube so that the moulded 'joggle' (step) is parallel and the middle of the joggled edge meets the tube centre – Fig 119 below*



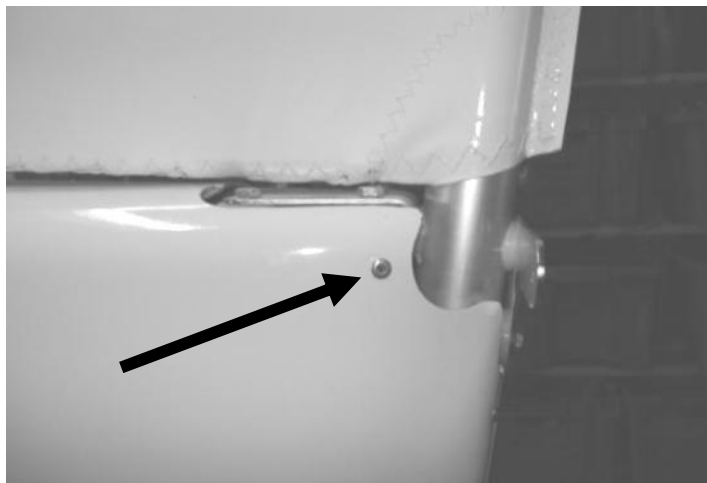
**Figure 119 showing alignment of rear fairing with TU6 upright tube.**

*This should also coincide with the rear of the fairing halves being butted up against the rear of the fin post – Fig 120 below.*



**Figure 120 fitting at rear against finpost**

- e) When correct positioning has been verified a 4mm hole can be drilled each side in the rear of the upper fuselage longeron in the position shown below and a 4mm / 5/32 cleco or skinpin (Light Aerospares - LAS sell them) inserted to hold the fairings in the correct fore and aft position. This will stop the fairings from sliding rearwards when final strapping tension is applied. A rivet will be put in this hole later after all other fixings are done.



**Figure 121 positioning hole**

- f) The strips can now be tensioned until all the top and bottom seams align. When a final verification of alignment has been made you can now start drilling the fixing holes.

*Strips of packaging tape pulled tight across the join can also be used to help draw the fairings together.*

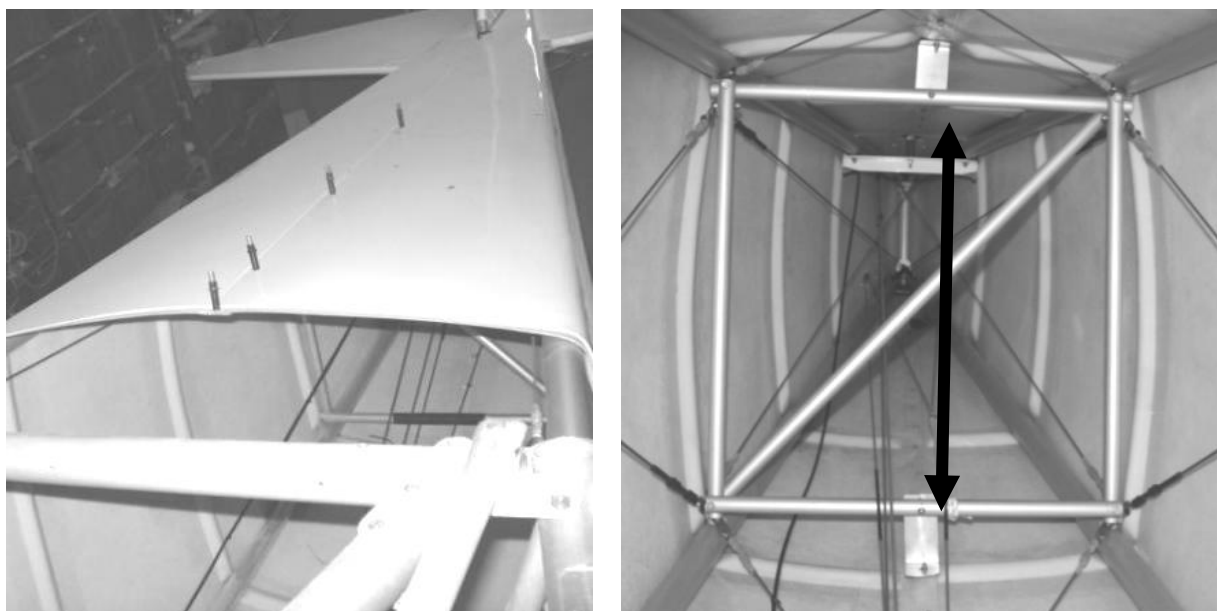
*Start first by drilling an upper and lower hole to fix the fairings on to the finpost. Make sure the halves are tightly together when you do this. Stretching some packing tape across between the two may help to pull them together for final fit.*

*When the holes have been drilled insert Cleco's / skinpins to hold in position.*

*Then move to drilling and fixing the fairing front sides to the TU6. Just make one hole each side and secure with Cleco's / skinpins.*

*The upper and lower seams have the positions marked for hole drilling with small dots in the moulding. Start nearest the finpost. Drill, secure with cleco/skinpins and move forwards.*

*Then move to the underside starting at the rear and again working forwards.*



**Figure 122 fuselage fairing seams held together with Cleco's, bracing angles**

- g) When all is drilled and verified drill and rivet the remaining positions on the finpost (fig 120). Use 5 white 4mm aluminium rivets.
- h) Then fix the top and bottom fairing seams using the white 4x10mm plastic screws and 4mm nyloc nuts. Use a 4x16mm stainless steel screw and nyloc nut for the front-most fixings top and bottom.

*Make up some 'creeper boards' (from the packing box is ideal with some strengthening battens) to put on the lower longerons to gain access to the inside beyond what you can easily reach.*

Alternatively 4mm countersunk rivnuts can be used in place of the nuts.

- i) Fit the two bracing angles shown in figure 122 above. These are there to support / stiffen the glassfibre upper and lower surface

*Make these up from some 1mm thick aluminium, bent into an L shape. Drill the horizontal tubes of the central frame 4mm holes in the centre to fix them. Fix them to the nearest bolts in the fairing (Change these to 4mm metal bolts). Drill to fit to the central brace (4mm bolts) so that no pressure is put on the glassfibre pushing or pulling.*



## 7. Engine Installation Rotax 912UL/912ULS

Note that the engine is LIVE until the magneto wires are grounded.

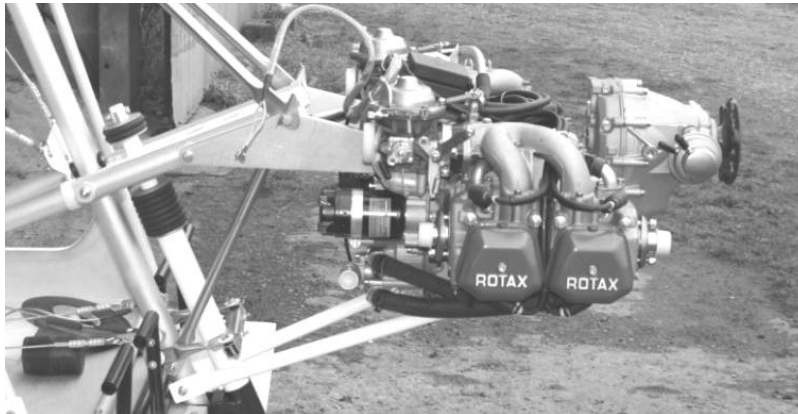


Fig 123 engine installation overview

### 7.1 Preparation

- a) Find a clean area to work on the engine, and then give it an even better clean: you do not want any dust or swarf etc. to get into your engine.
- b) Read the instructions which came with the engine for details of installation requirements, and for maintenance and operating procedures.
- c) Remove the carburettors and air filters by loosening the screw clamping the carburettors into the rubber mounts and sliding them out. Cover the exposed holes with tape or similar.

*When reinstalling the carburettors the rubbers should be degreased to remove any oil, and the clamps tightened as specified in the engine instructions.*

- d) The water pump inlet on the bottom rear of the engine must be turned so that it points at 90 degrees to the starboard side of the engine, see the engine instructions for the procedure.

*Take care not to lose the O-ring seal and note the torque value of 10Nm (1kgm, 7ftlb) for the fixing screws.*

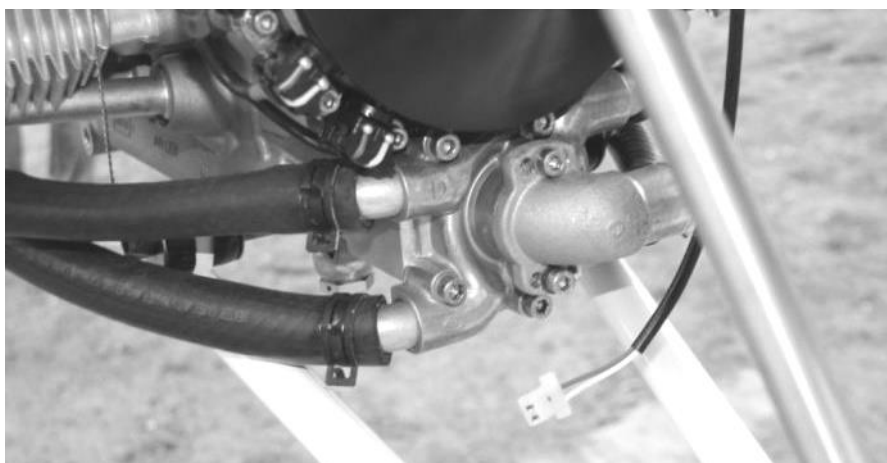


Figure 124 water pump outlet in correct position

- e) Remove the upper rear case bolt located above the starter.

*This bolt will be replaced with a 10mm x 140mm Allen head machine bolt when the engine is fitted.*

- f) The upper port mounting bolt will not clear the cylinder head fins. The fins must be trimmed with a file, a small Dremel grinding tool, or similar method. *Don't be frightened of this – it will be much easier if you grind off a generous amount! Remove the inlet manifold to get good clear access – but protect the opening to the cylinder heads with tape or similar to prevent swarf getting in!*
- g) Trial fit the bolt, including the rubber mount and washers, to make sure you have trimmed enough off. Ensure an easy fit, to eliminate any risk of cross-threading the bolt.



**Figure 125 upper port mounting bolt.**

- h) Drill a small hole for lock-wire in the heads of all four 10mm diameter engine mounting bolts.

*Use a new, good quality bit, drill slowly, and lubricate with 3-in-1 oil.*

- i) Push the rubber mounts firmly into their holes in the engine mounts. On the upper plates position them so the male halves are fitted from outside to inside – this makes changing them in situ much easier later in the life of the aircraft.

## **7.2 Mounting**

- a) Position the engine on the Nynja making sure you do not bump the CDI pickups located on top of the flywheel.



**Figure 126 engine mounts.**

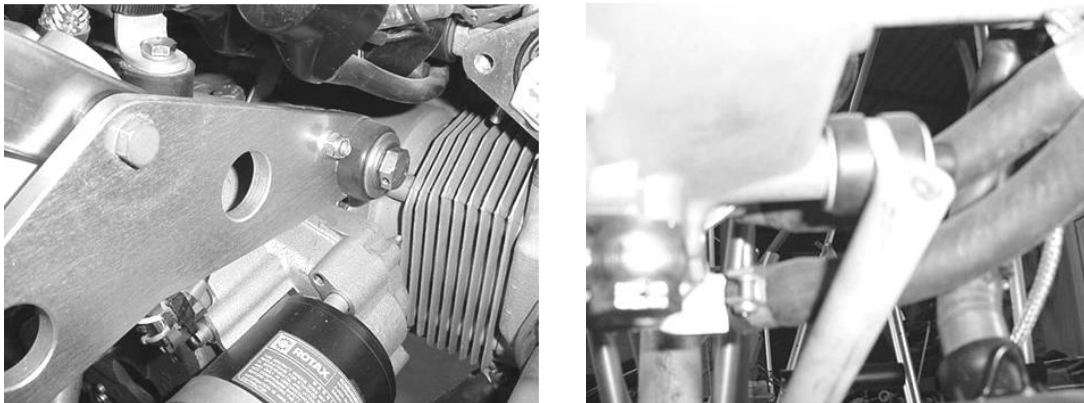
*Support the engine on a bench, such as a workmate, chock it up to the correct height, and offer the fuselage up to it. An engine hoist (which can be hired from your local hire shop), or some other method of lifting the engine may be used as an alternative.*

*Be careful how you support the engine, do not let its weight bear on any of its many ancillary parts such as the spark plugs, filters etc.*

***Warning: do not let the engine tip forwards whilst connecting the upper engine mounts to the mounting plates as damage will occur to the rear of the engine.***

- b) Fix the upper starboard rubber engine mount between the two penny washers with the long 140mm bolt.
- c) Fix the upper port rubber engine mount between the two washers with a short 60mm bolt.
- d) Fix the lower starboard rubber engine mount between the two washers with a short 60mm bolt.
- e) Fix the lower port rubber engine mount between the two washers with a short 60mm bolt.

*A good tip to make this less fiddly is to fix the penny washers to the rubbers in advance, with a dab of superglue. Saves some washers from rolling across the workshop floor and quite a bit of profanity..!*



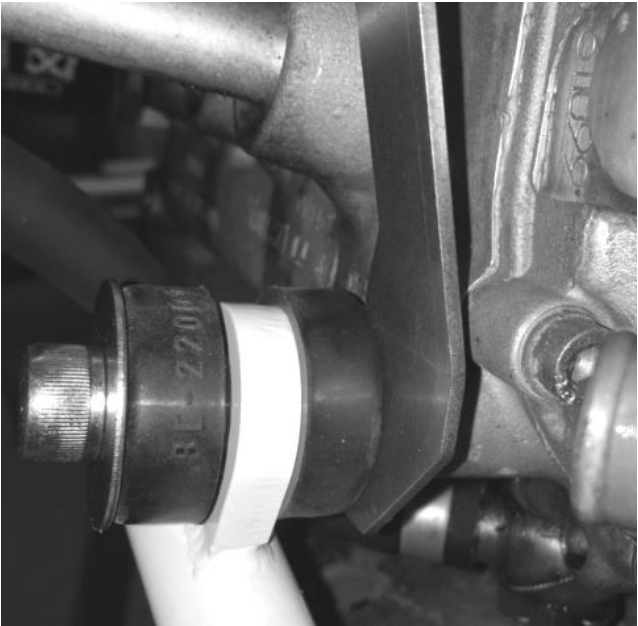
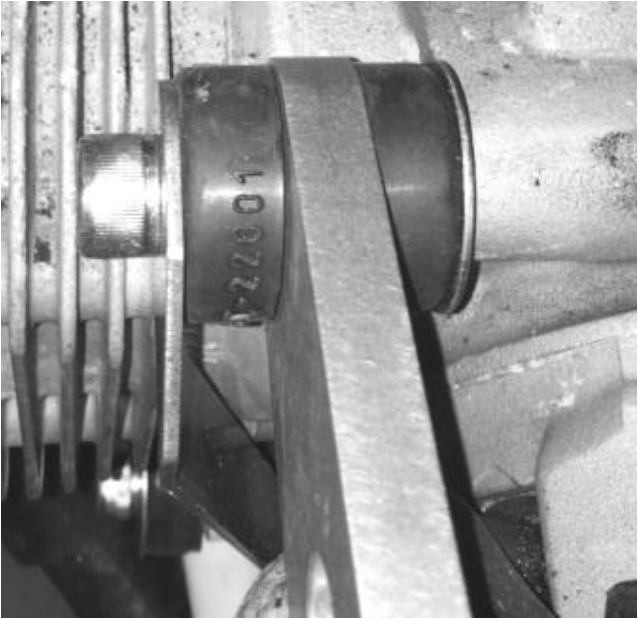
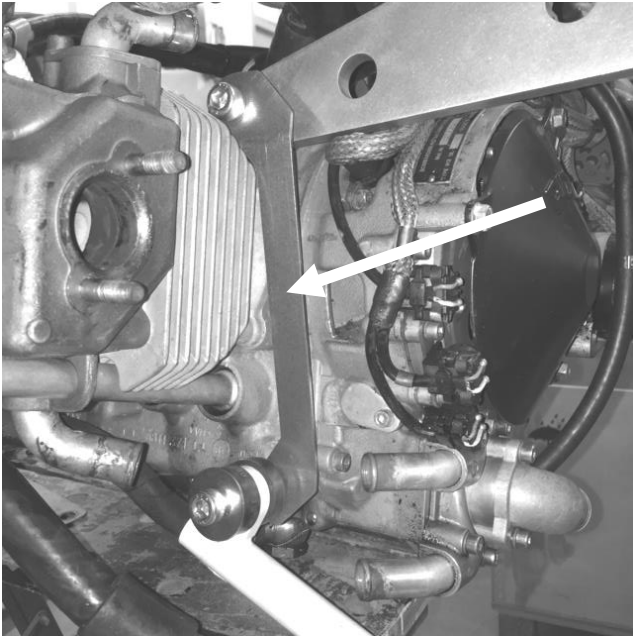
**Figure 127 upper starboard and lower port mounting bolt.**

- f) Tighten the bolts to a torque of 38Nm (3.8kgm, 27ftlb).
- g) Wire-lock the engine mounting bolts.

### **7.3 Bracing strap**

For 912ULS engines which have high torque and start acceleration an additional bracing strap is fitted on the port side on the engine. It is not necessary to fit this to the 912UL engine, but we include it in new kits and recommend it. The strap replaces the snubbing washer on the outside of the top engine mount rubber and runs down to

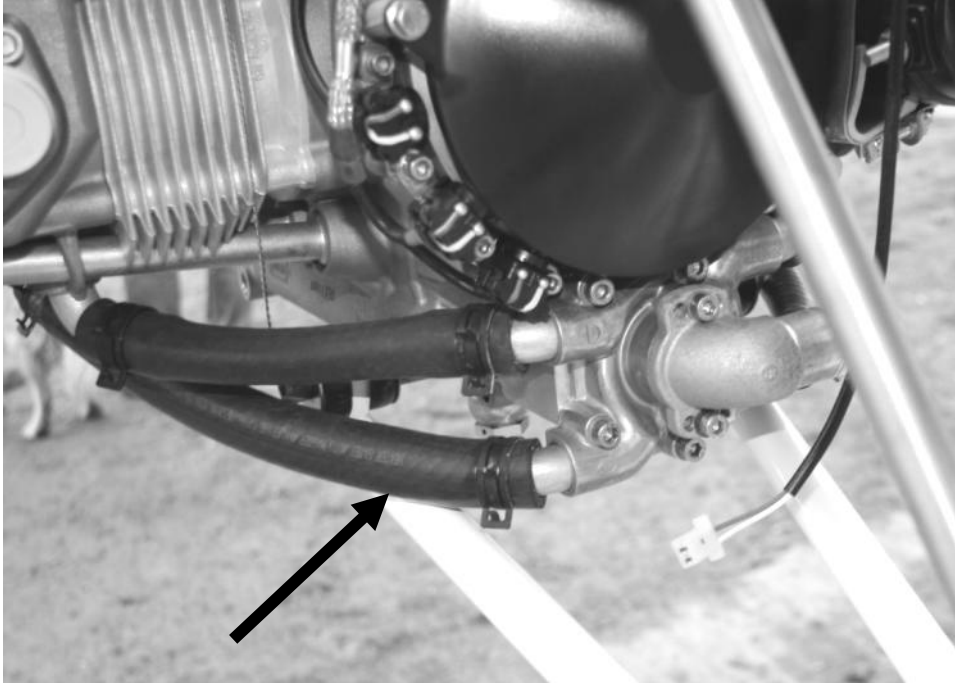
the replace the subbing washer on the inside of the lower engine mount rubber. This then provides support against bending loads due to torque being applied to the top engine mount bolt.



**Fig 128 Overview and views of the upper and lower attachment points of the bracing strap**

## 7.4 water pump outlets

- a) The position of these outlets are subject to some variation from the engine manufacture. The lower port outlet can be very close to the engine mounting leg or foul it.



**Fig 129 area of possible fouling between water pipe and lower engine mount**

- b) If this is the case the outlet elbow must be rotated. To do this:
1. *Remove the water pump housing. Heat the area where the outlet pipe screw in with a plumber's gas blowlamp, in order to soften the Loctite used to secure the outlet elbow into the threads. When seal is broken and the elbow can be rotated, allow to cool and then remove completely.*
  2. *Clean all the threads thoroughly. Refit the assembly and screw in the elbow to the right position. Mark the correct position with a pen line.*
  3. *Reassemble using Loctite243, positioning the outlets with reference to the marks.*
  4. *Refit to engine and connect hoses*



c) Join the leading and trailing edge tubes with the oval tube **SKR37.3** (maybe marked **SKR54**) at the tip, Figs 142,143,144.

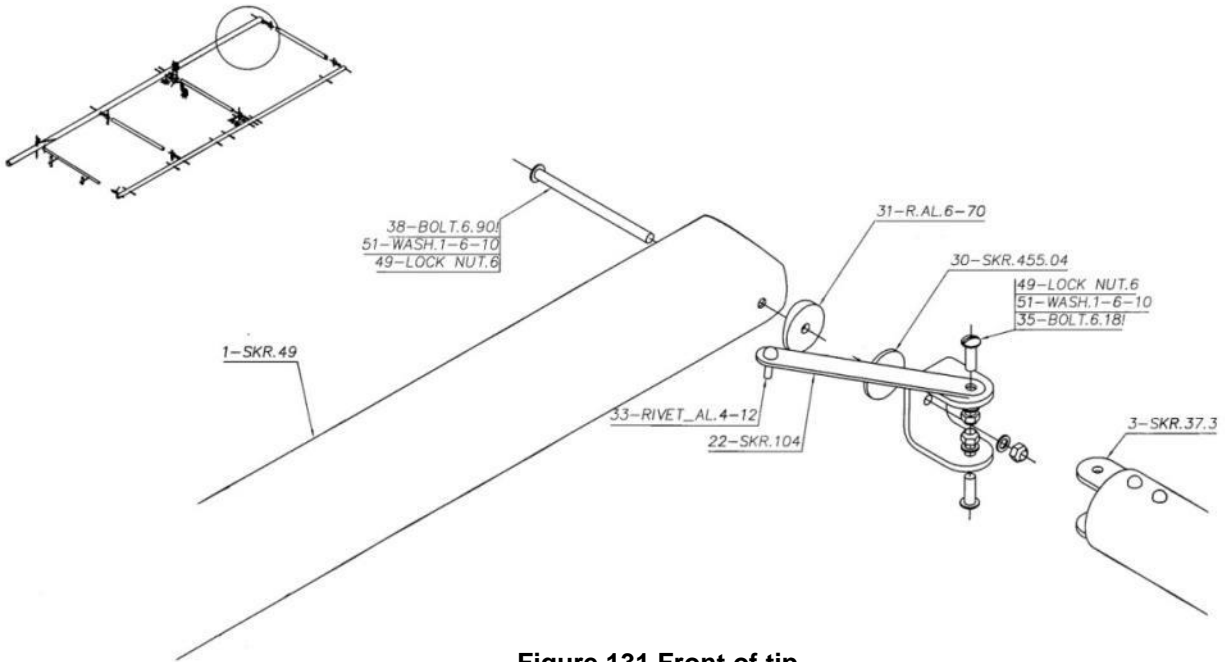


Figure 131 Front of tip

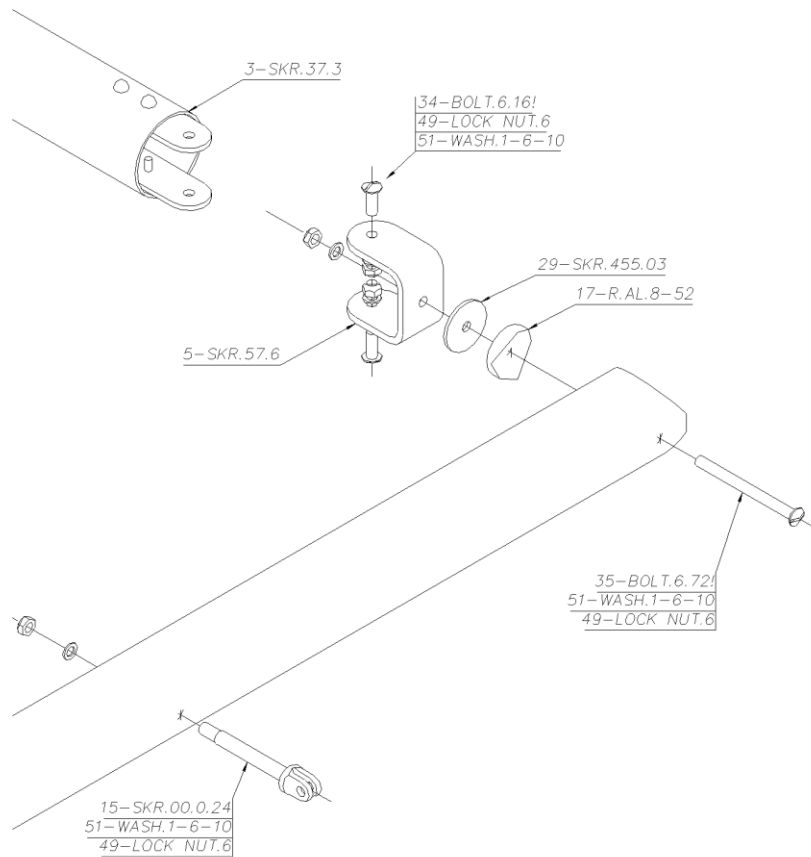


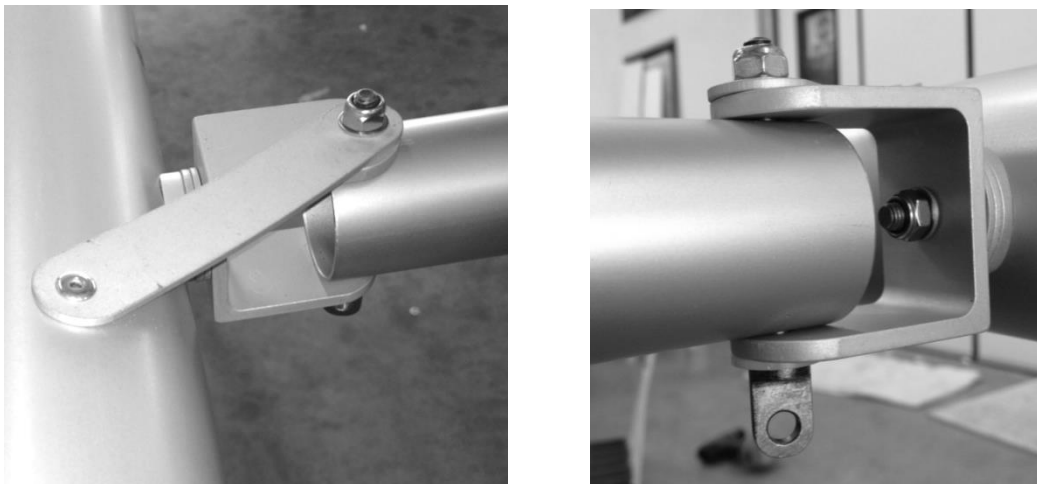
Figure 132 rear of tip.



**Figure 133 wing tip– trailing edge, leading edge.**

- d) Use a round **SKR37** tube to join the leading and trailing edges at the jury strut location,
- e) The orientation of the bracket that holds the jury struts should be long side downwards and towards the tip

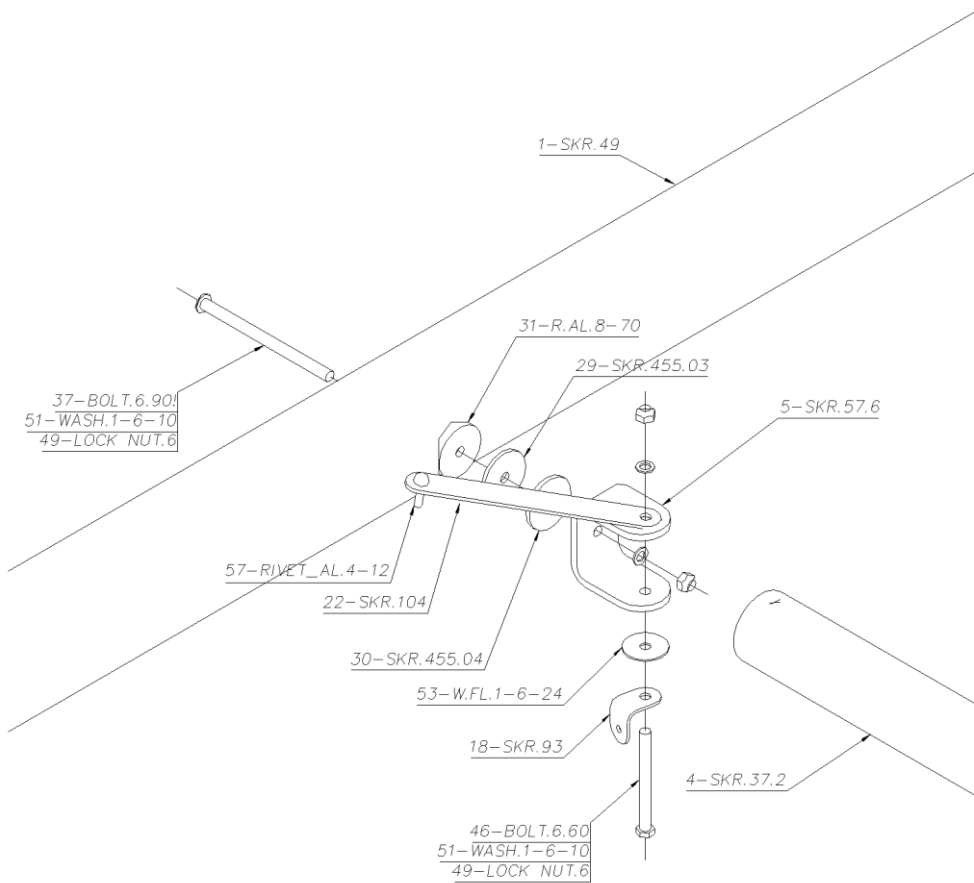
*The orientation of the bolts should be head downwards, to maximise clearance from the jury struts when they are fitted at the very end of this manual. They must not be fitted sooner, as their length depends upon the exact alignment and tension of the airframe.*



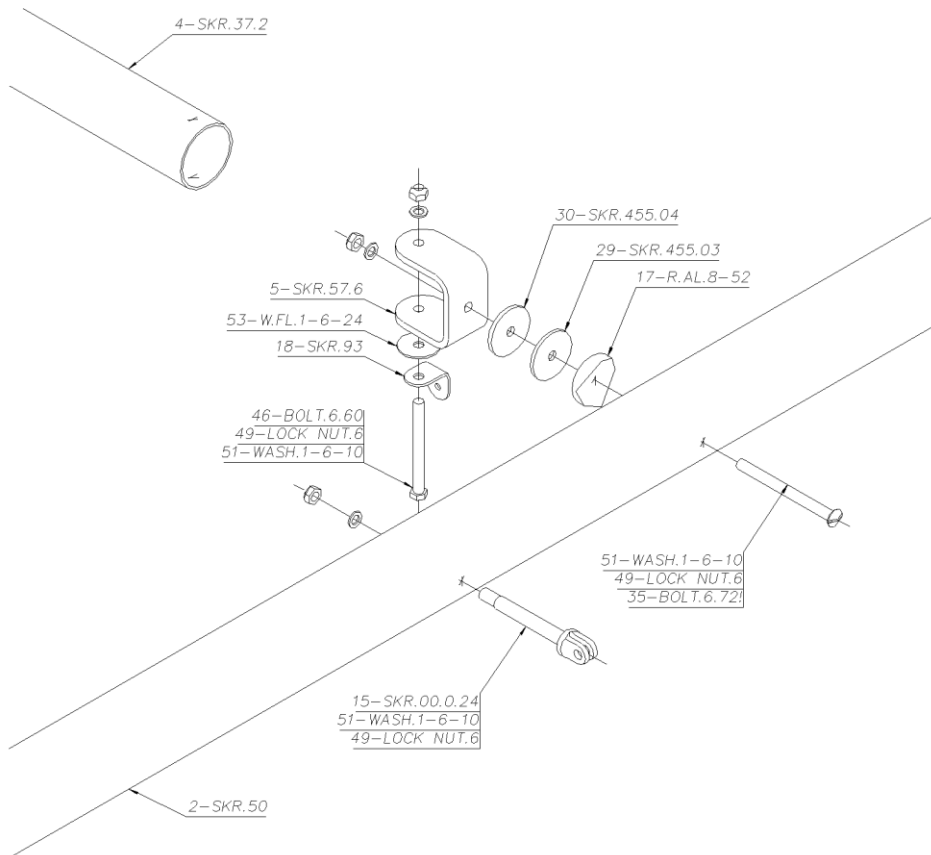
**Figure 134 forward and rearjury strut attachments.**

*Note: The Aerofoil section jury strut option (Swift and Nynja) uses a different upper mounting, replacing the bolts and small L brackets in the following drawings with eyebolts as above. Note they may be either male ended (as shown above) or female ‘forked’ ends. They may need washers to pack out excess plain shank length.*





**Figure 135 front jury strut attachment.**



**Figure 136 rear jury strut attachment.**

- f) Rivet the small aluminium strips, located on the top of the **SKR37** tube attachments at the tip and the jury strut locations, onto the top of the leading edge tube, pointing towards the wing root.

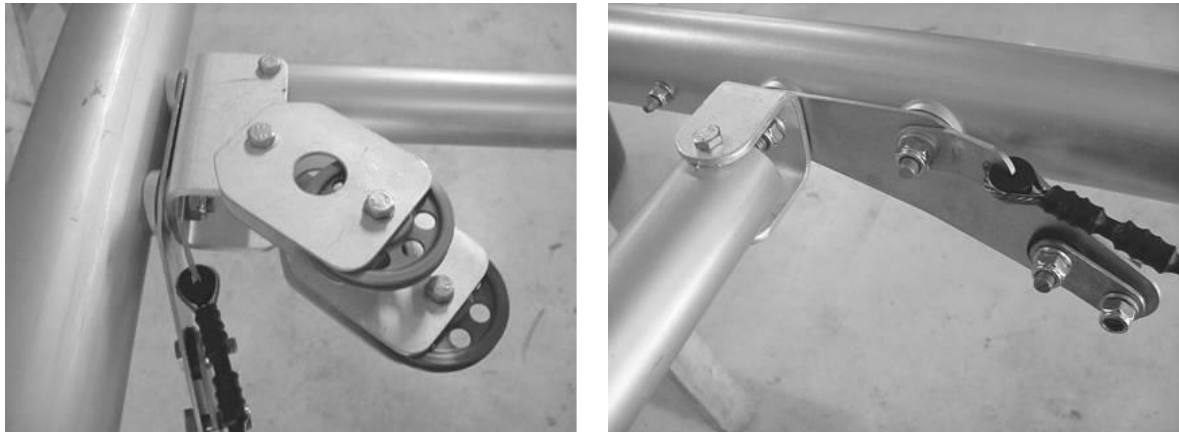
*Use 4mm aluminium rivets. Rivet on just behind the centre of the leading edge tubes otherwise they can press into the covering leaving a small but annoying bump! These plates hold the brackets and tubes from turning.*

*Use another round **SKR37** tube to join the leading and trailing edges at the lift strut location.*

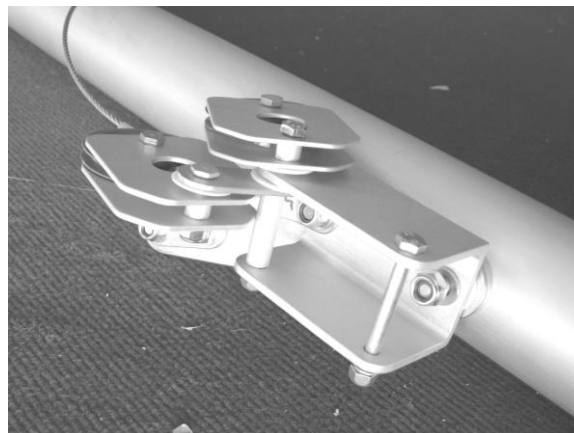
*Don't forget to attach the bracing cables at the lift strut ends: the one with the turnbuckle to the trailing edge, using the end without the turnbuckle; and the one without the turnbuckle to the leading edge.*

*Note the altered arrangement of the aileron pulleys, Figure 138. A spacer tube has been incorporated between the top and bottom parts of the U-bracket, with the lower pulley bracket held between the spacer and the upper part of the U-bracket. The upper pulley sits on top of the U-bracket, with a thin plastic washer between it and the bracket.*

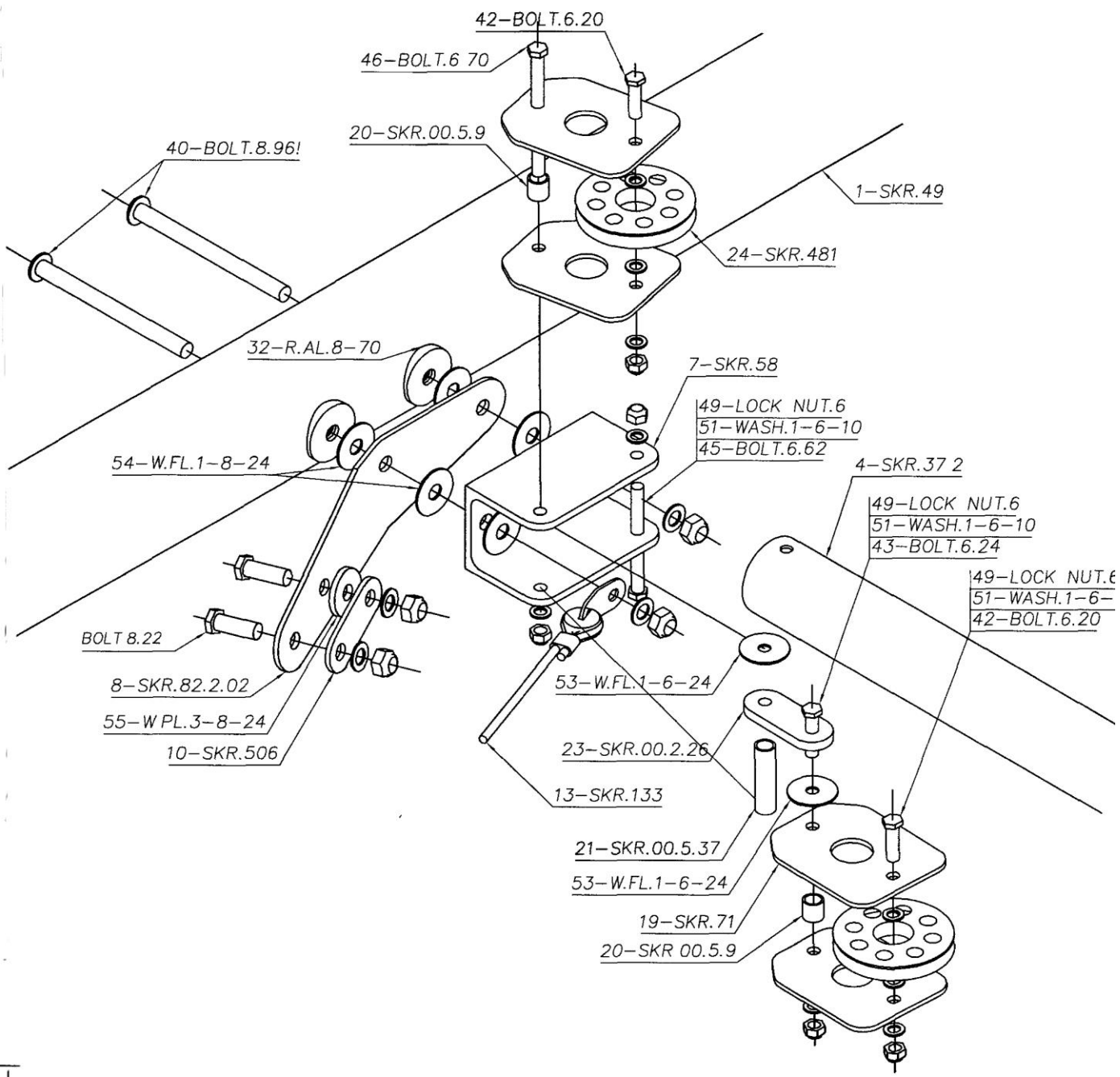
*Leave the bolt securing the pulleys loose at this stage, to allow the aileron cables to be passed through later.*



**Figure 137 lift strut attachments.**

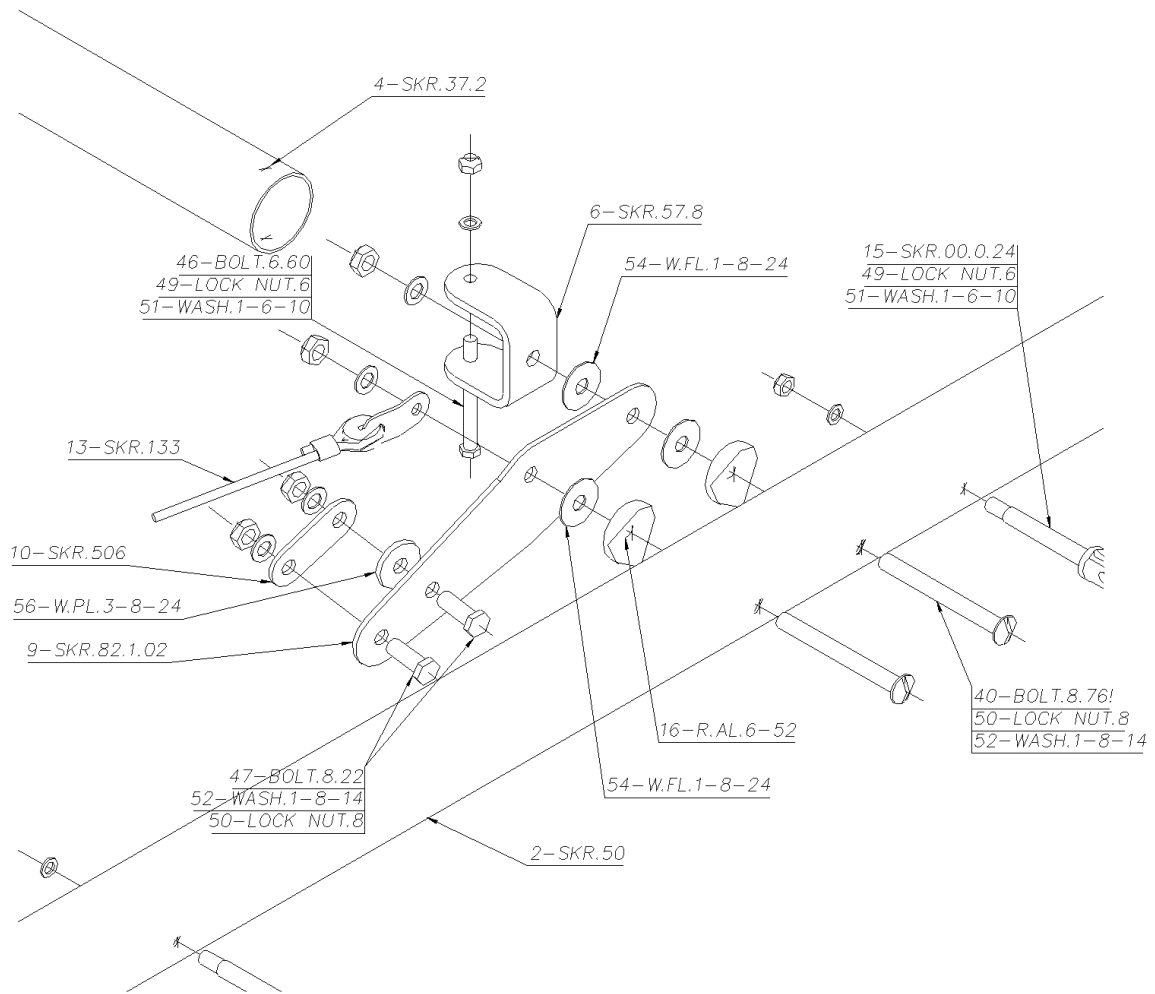


**Figure 138 UKMOD aileron pulleys.**



**Figure 139 front lift strut attachment. And UK MOD pulleys**

**( The bolts holding the pulleys and the tu37 should point upwards to avoid pressing against the coverings. Alternatively they may point downwards, but then nutcaps must be used to protect the coverings from the protruding bolt ends. )**



**Note:** the lift strut plates (front and rear) have changed slightly and are now in common with the LS version spec and have an extra hole and link plate, and front has a brace tube – they should be assembled as below:



**Figure 140 LS front and rear lift strut attachment assemblies.**

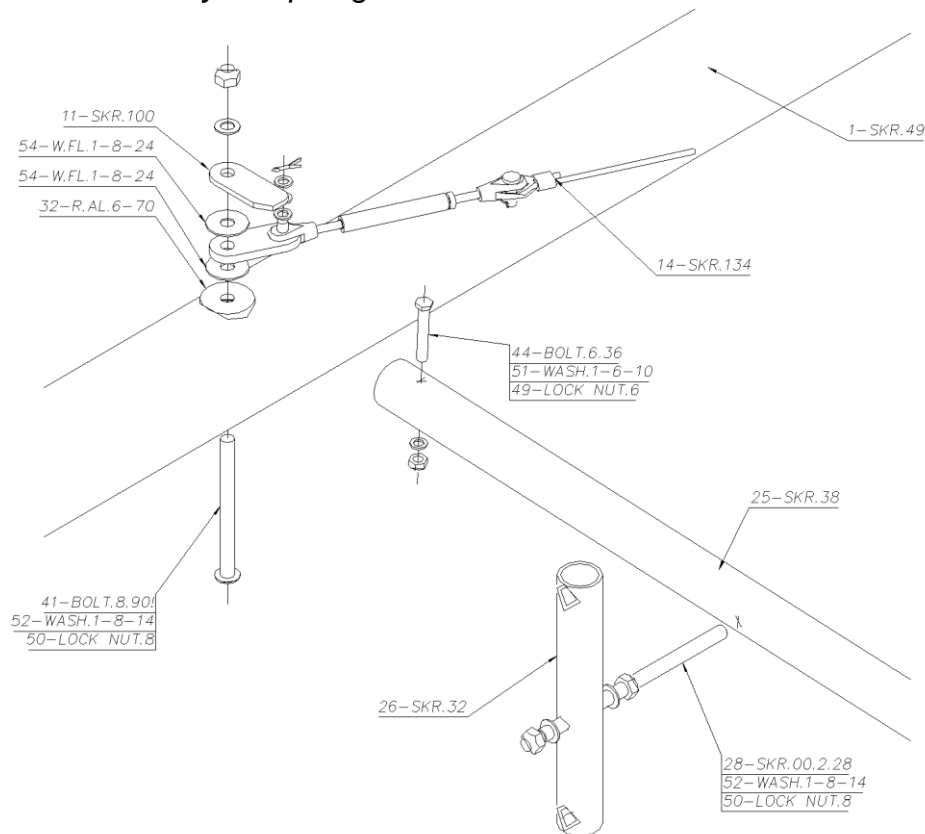
- g) Attach the bracing cable without a turnbuckle to the fuselage end of the trailing edge tube
- h) Attach the bracing cable with the turnbuckle to the fuselage end of the leading edge tube, with the turnbuckle at the fuselage end.

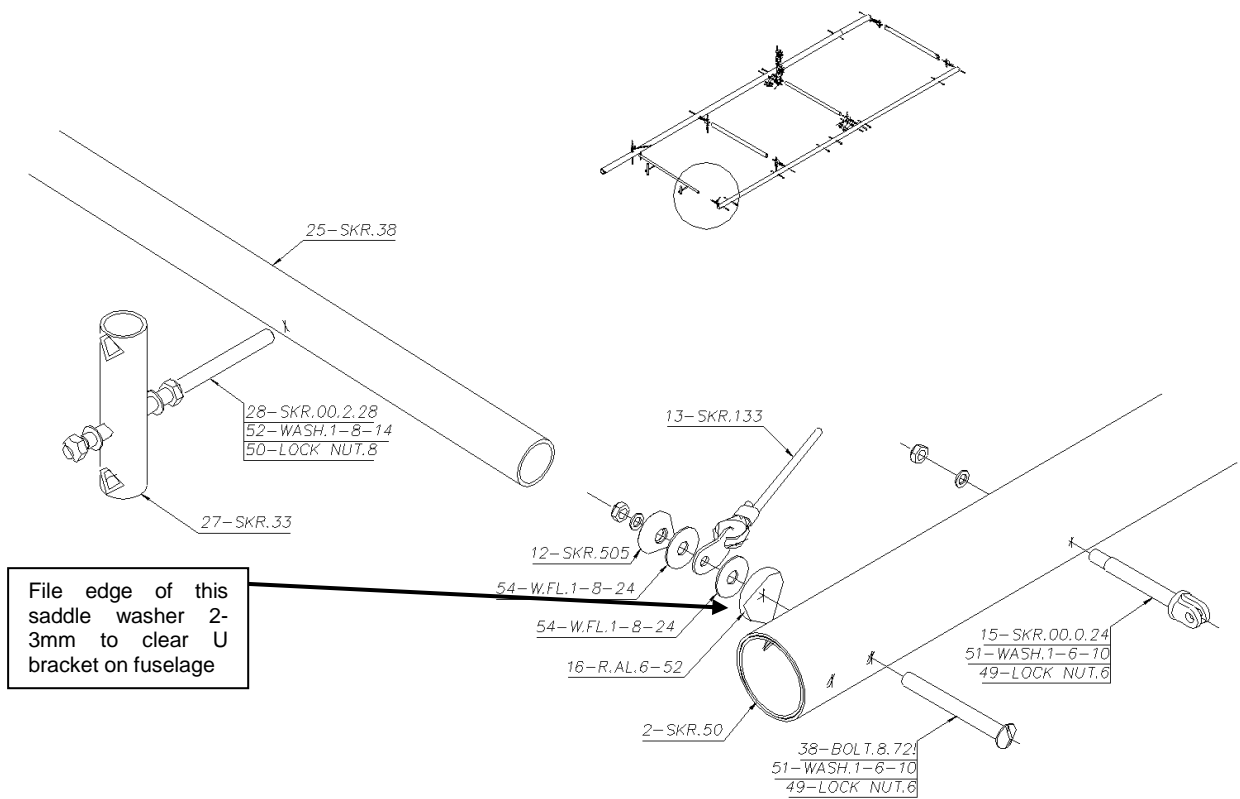
*Make sure that the cables cross and run over tube **SKR37**. The cable with the turnbuckle must be over the other cable. If the sleeving on the cables is not in the correct location it may be slid along the cable by heating it first with a heatgun. If this does not work, protect the tube where the cables cross with some prop tape.*

*Do not tighten the turnbuckle yet, as the compression tubes are not yet fitted.*

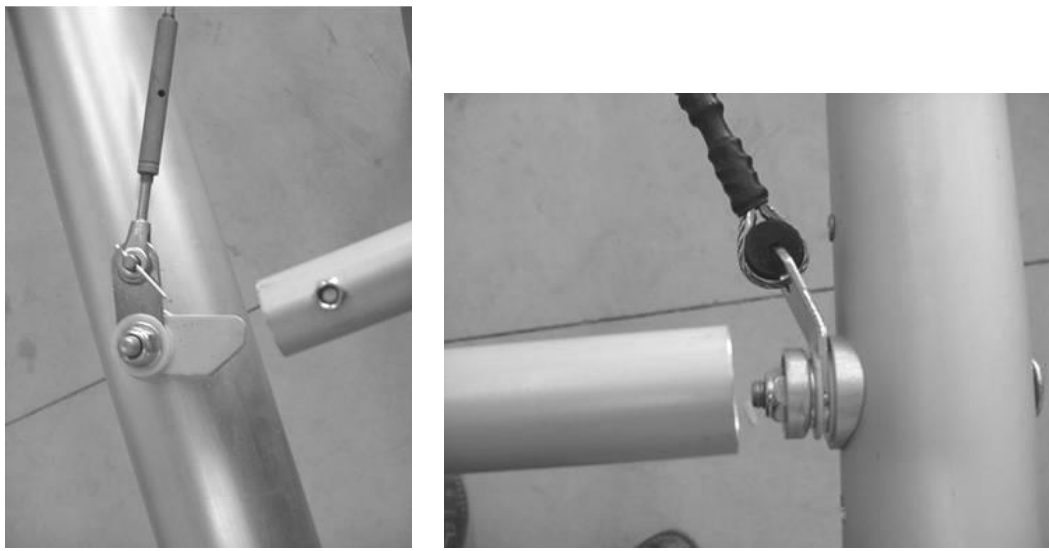
*The split pins can be secured now, but do not wirelock the turnbuckle until the covering has been fitted.*

*To protect the coverings the bolt securing the turnbuckle should be cut off leaving only a couple of threads showing above the Nyloc. File to remove any sharp edges.*



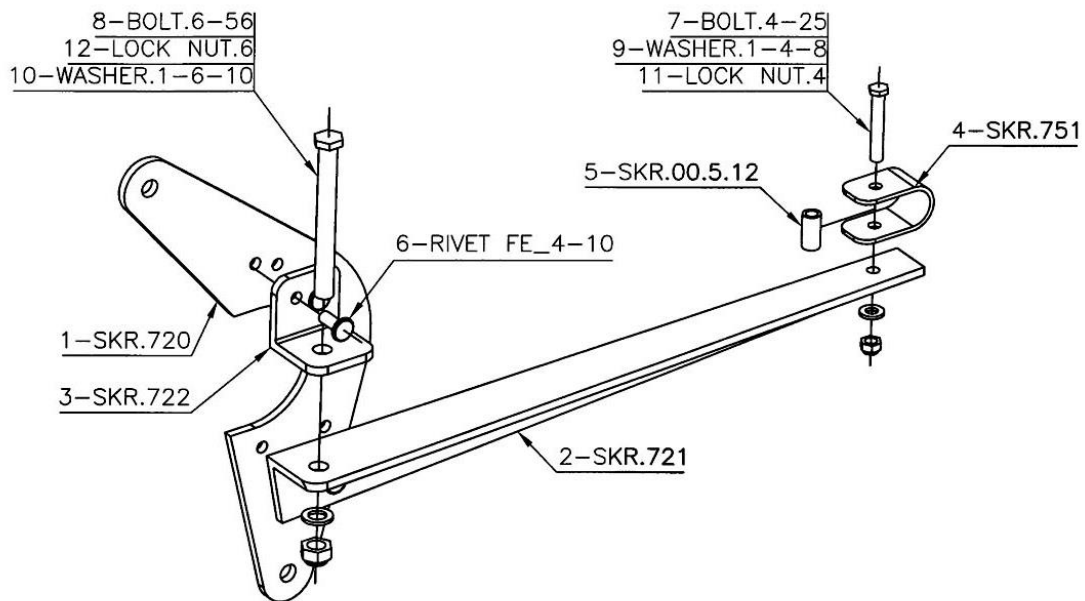


**Figure 141 front and rear of tensioning tube.**



**Figure 142 tensioning tube fittings, front in left photo (note bolt through compression tube), rear in right photo.**

## 8.2 Aileron Horn Assembly



**Figure 143 aileron horn parts.**

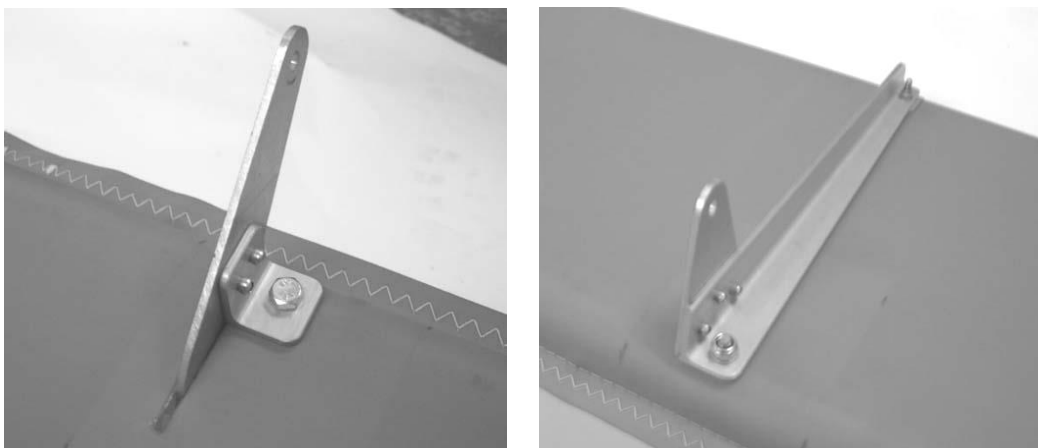
- a) Find the hole in the aileron leading edge spar.

*This is located 480mm from the inboard end of the spar.*

- b) Burn through the fabric with a soldering iron at this point to uncover the hole.  
 c) Lightly bolt into position the upper and lower angles.

*Use the 6mm bolt with 45mm shank length.*

*The long brace goes underneath with horizontal edge facing the inboard end of the aileron, placing the horn towards the wing tip.*



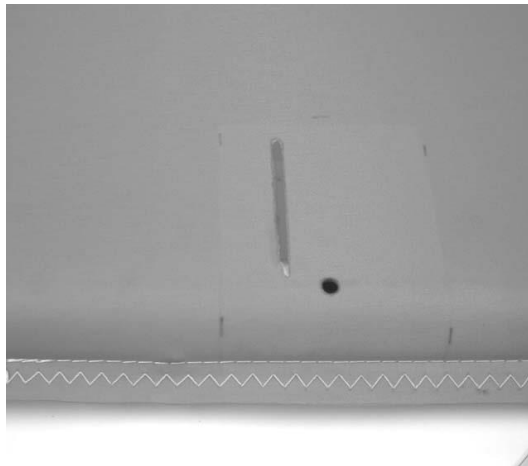
**Figure 144 aileron horn, top and bottom.**

- d) Temporarily mount the aileron onto the wing, and line up the long brace to point at the aileron pulleys.

*This will put the brace at around 90° to the trailing edge of the aileron.*

- e) If the aileron movement feels at all stiff, the holes for the eyebolts on the trailing edge may need to be eased slightly to achieve good alignment and thus easy movement. Once satisfied tighten the eyebolts, remembering the Loctite, and do not over-tighten (as a guide they should still be able to turn with only moderate finger pressure).
- f) Burn a small hole in the fabric at the trailing edge through the 4mm hole at the rear of the brace.
- g) Burn a hole in the same position on the upper surface fabric.
- h) Remove the aileron from the wing.
- i) Insert a 4mm bolt to hold the angle in position and using the angle as a guide burn a slot 60mm long on the under surface measured from the centre of the leading edge spar, Figure 145.
- j) Use the long brace from the opposite aileron against the upper surface as a guide to melt the upper slot.

*This slot should be 50mm long measured from the centre of the leading edge spar.*



**Figure 145 slot for the aileron horn in the under surface of the aileron,**

- k) Put the braces back in their correct positions and secure the trailing edge with a 4mm bolt passing through the thin sheet aluminium U-piece, the spacer tube and the lower brace, the sequence shown in Figure 143.

*Note that the U-piece edges should be bent up slightly so that the edge does not cut the fabric over time.*

- l) Tighten this assembly, and also tighten the 6mm bolt holding the front of the top and bottom braces.
- m) Insert the aileron horn.

*If it is a tight fit through the fabric you may have to lengthen the slots a little.*

- n) Check the alignment of the rivet holes.

*These may have to be gently eased with a 4mm drill or reamer.*

- o) Insert all rivets, from the horn side, to ensure they all fit, then pull up the rivets.



### 8.3 Attaching the Wings to the Fuselage

Note this is a temporary fitting, before removal for covering and transportation. However, it should be performed in order to allow easy setting up of the controls.

- a) Select the front and rear lift struts **SKR92** and **SKR91**.
- b) Lay them on the ground next to the fuselage in the position that they would attach.

*The inboard ends are those fitted with the angled stainless-steel brackets.*

*The strut with the angle cut out of its trailing edge is the front strut.*

- c) Attach the struts to the main undercarriage cross-beam, **SKR9**.

*The plastic washers between the strut ends and the main beam shown in Figure 146 are not required.*

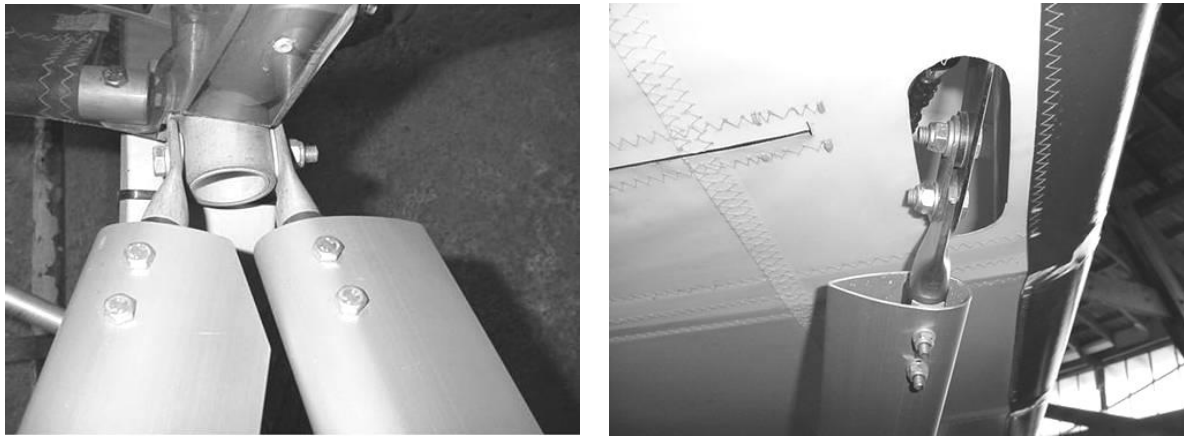


Figure 146 lift strut attachments.

- d) With two people, attach the wing to the fuselage.

*One person should hold the tip up while the other person puts the pins through the U-brackets to secure the leading and trailing edges on the fuselage.*

*Put the leading edge pin in first, from the rear, then the trailing edge pin, from the front.*

- e) Lift the struts up to the wing and attach them to the leading and trailing edges, Figure 146

*Do not install the jury struts at this stage, wait until the wing has been covered and the geometry checked. This will happen at a later stage.*

*Do not overtighten the upper bolts holding the lift struts to the wings, there is no need to distort the connecting brackets.*

*Check that the lower strut attachments lie nice and flat against the TU9 tube. If not carefully bend them until they do.*

## 8.4 Aileron Control Cables

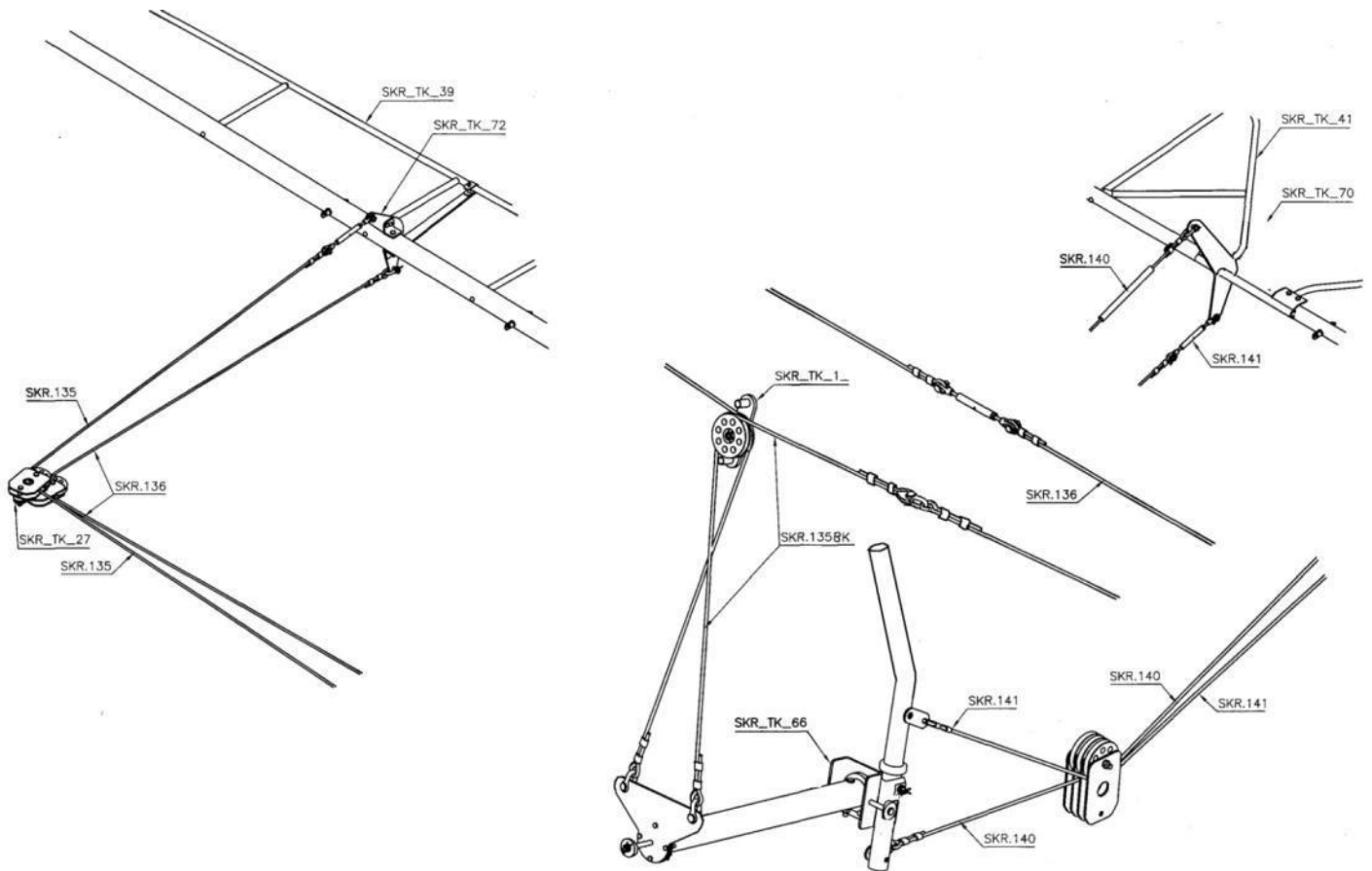


Figure 147 aileron cable runs.

- a) Temporarily fit the ailerons onto the wings.
- b) Check the ailerons for unrestricted movement.

*If any friction is felt the holes in the trailing edge where the eyebolt hinges attach should be elongated slightly along the tube. This is worth doing on all the hinges, even if no friction is present at this stage, as when the coverings are fitted they tend to build some stress into the wing and cause the ailerons to bind slightly which spoils the feel of the controls.*

- c) Select the pair of upper aileron cables, those with the turnbuckles on one end.
- d) Thread the ends without the turnbuckles around the upper pulleys inside the wings and through the U-brackets at the jury strut attachment locations.

*Work from the ailerons inwards towards the fuselage.*



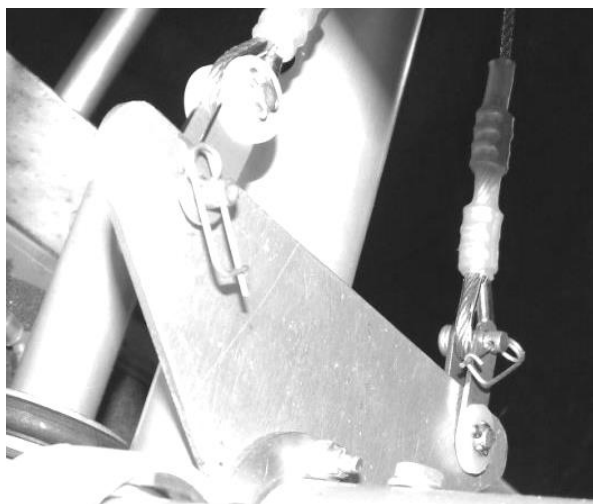
**Figure 148 cable routed through U-bracket.**

- e) Pass the cables around the pulleys at the top of the front vertical tube **tu14** where the leading edges attach, Figure 147.
- f) Prepare the fittings for attaching the aileron cables to the driving horn connected to the control stick.

*The Nynja may be supplied with Aileron cables with derig connections on the sections from the pulleys on top of the TU14 tube where they run along behind the front wing spar tube before entering the wing. If these are fitted then the cables attach to the driving horn using the shackles as supplied and as shown in drawing figure 147 above, and the following down to j) can be disregarded:*

*If using the full length cables, attach a pair of the stainless steel plates to the port aileron cable using a shackle pin and two plastic washers on the outside of the plates to take up some of the slack, and permanently secure with a split pin, figure 159.*

*Attach the other pair of stainless steel plates to the starboard side of the aileron driving horn, again using a shackle pin with a pair of plastic washers outside the plates, permanently secured with a split pin.*



**Figure 149 aileron cable connections viewed from beneath.**

- g) Attach the starboard aileron cable end to the stainless steel plates on the starboard side of the aileron horn using a shackle pin and a nappy pin or split ring.
- h) Attach the stainless steel plates on the port aileron cable to the port side of the aileron horn using a shackle pin and nappy pin or split ring.
- i) Attach the turnbuckles to the upper control horns.



**Figure 150 aileron cable fuselage pulleys.**

- j) Select the other aileron cables **ca6** which are connected in the middle by a single turnbuckle.
- k) Pass the ends of the cables **ca6** over all the tubes in the wing and the fuselage (except the windscreen supports) and around the lower pulleys inside the wing.

*Loosen the turnbuckle and feed the other ends from the fuselage outwards towards the ailerons.*

- l) Attach the ends to the lower control horns on the ailerons.
- m) Tighten the bolts securing the aileron pulleys in the wings.

*Ensure the pulleys can still move to take up the correct angle to the cables.*

- n) Check the gap between the pulley and the plates to make sure that it is not more than 1mm or so.

*If it is, there is a chance that the cable could jump the pulley and slip between the plate and the pulley. If there is an excessive gap, check the plate for bends and check for the proper washers between the pulley and the plate.*

- o) Tension the cables by hand to check that all the cable lengths are accurate.
- p) Check the angle of the lower pulley bracket inside the wing.

*This is the bracket for the cable **ca6** that connects to the lower control horn on the aileron. You will need to bend the bracket with a twisting*

*motion so that the pulley is in the same plane as the cable, and moves smoothly.*

- q) A short plastic sleeve should be fitted over each of the central cabin tubes **SKR19**, immediately behind the front vertical **SKR14**, to form aileron horn stops, Figure 151.

*These will require cutting to slip over the tubes if not installed earlier, and to allow packing out later to set the aileron deflections.*



**Figure 151 aileron stops.**

- r) Set the levelness of the ailerons with the turnbuckles at the ailerons, whilst the centre turnbuckle simply takes up the slack.

*Final adjustments to neutral position and control surface movement will be done when the aircraft is complete.*

- s) Check the right and left joy stick movements for the proper aileron deflection: stick left, left aileron up, right aileron down and vice-versa.
- t) Check for any stiffness and binding.
- u) Small pieces of prop-tape can be applied to tubes where the cables may occasionally touch them, but the cables should not be rubbing continuously on any tubes.
- v) If the cables are found to “slap” against the leading edge tubes within the cabin area, either apply tape, or position a couple of cable ties or similar around the leading edge tubes to act as buffers for the cables.

## 8.5 Flaps

- a) Remove the horns on the flap roots.
- b) Fit the longer Nynja items.

*These fit on the other side of the tube. Cut a slot in the fabric to facilitate them.*



Fig 152 Nynja Flap horns

- c) Temporarily mount the flaps on the wings.

*If the pin securing the wing trailing edge to the fuselage touches the leading edge tube of the flap, the pin should be shortened to fit.*

*The control rod mounting plates at the flap roots face downwards.*

- d) Attach the push rods for the flaps to the flap handle,.

*The slightly longer flap pushrod and the longer spacer tube goes on the starboard side of the rear end of the flap handle.*

- e) Attach the push rods from the flap handle to the plates on the flap roots.

*The plates may require a tweak to line them up with the pushrods.*

- f) If the flap lever rubs the cables, check the fitment of the flap lever and adjustment of the cables against the respective instructions.

*If the starboard flap pushrod still rubs the control cables (due to the UKMOD controls) cut a few mm length off the port side spacer tube and add it to the starboard side spacer tube.*

- g) Check the smooth operation of the flaps, including moving the ailerons to check for any contact between them.

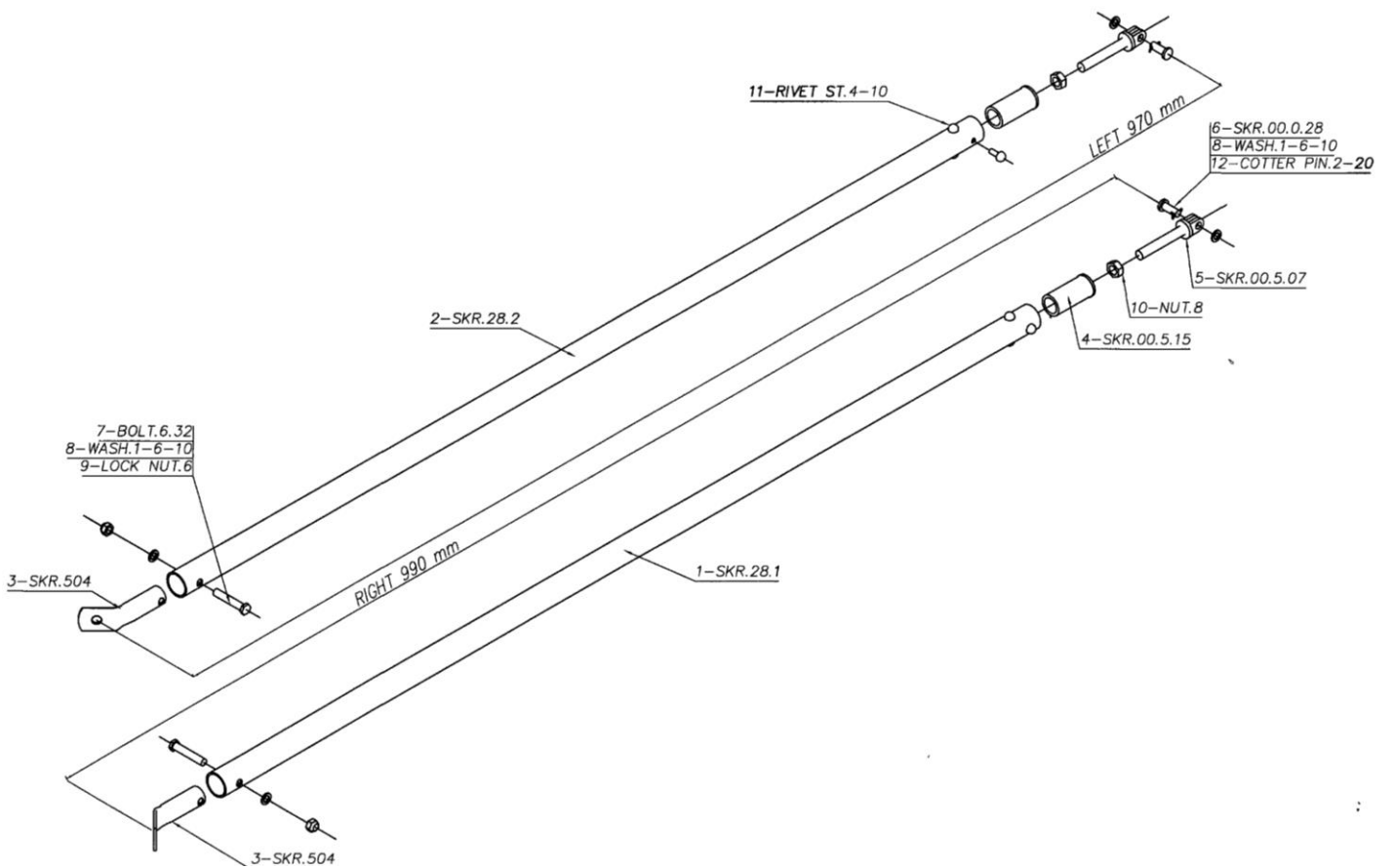
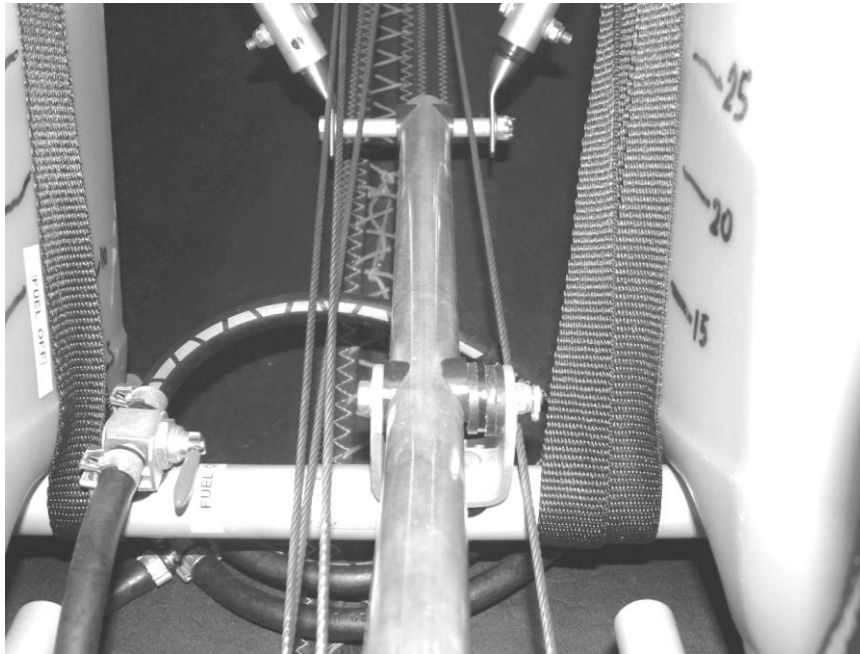


Figure 153 flap handle, looking rearwards and flap rods (note Nynja flap rods have slight bend in upper ends, not shown in this drawing)

## 8.6 Covering the Wings

- a) **Do not cover the wings until they have been inspected!**

*See the inspection schedule.*

- b) Select the odd-one-out from the battens: the trailing edge fitting is flat rather than forked, lay this one aside for the cabin roof.
- c) Select a typical batten and draw around it onto a large sheet of paper, to make a template for checking the batten profiles later should this be required after repairs etc.
- d) Check the battens and their fittings for any sharp edges which might damage the coverings.

*Smooth the ends with glass paper or similar if necessary.*

*Polishing the battens with car wax makes them slide in more easily, but on no account do this for aircraft with Dacron coverings if you intend to paint or lacquer the aircraft, the reaction will not be a pretty sight!*

- e) With two people remove the wings from the fuselage.

*Remove the lift struts from the wings followed by the fuselage, then remove the wings from the fuselage and lay them down flat in a very clean place.*

*Do not place the wings on concrete as it will scuff the cloth when you cover the frame.*

- f) Apply a layer of clear, thin, lightweight self-adhesive plastic film, such as Fablon, or clear waterproof tape, to the leading and trailing edge tubes and wing tip tubes where they touch the covering.

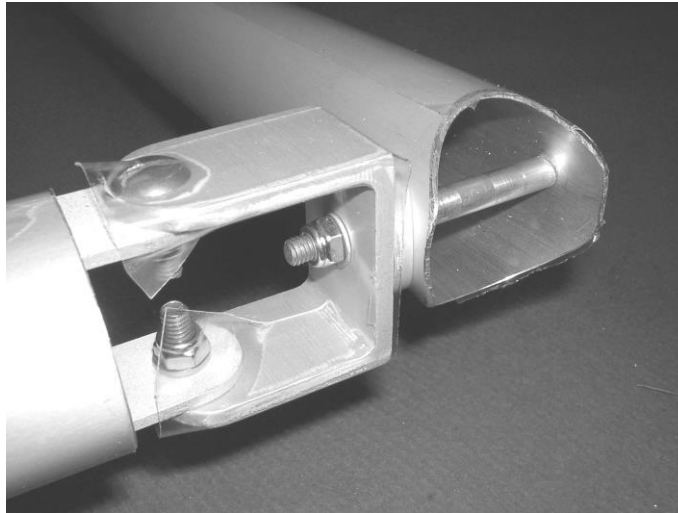
***Do not skip this step!*** *This prevents vibration from abrading the anodising, which can then cause unsightly stains visible through the covering.*

*To save weight just apply the film where the cloth can touch the tubes. If desired to increase resistance to corrosion it may be applied to the whole circumference of every tube, which will protect these difficult to clean areas.*

*Do not use thick, heavy tape, such as prop tape or gaffer tape, as this adds too much weight, is too grippy, and can look horrible!*

- g) Thicker tape should be applied only to the U-brackets at the wing tips to prevent chafing of the coverings.

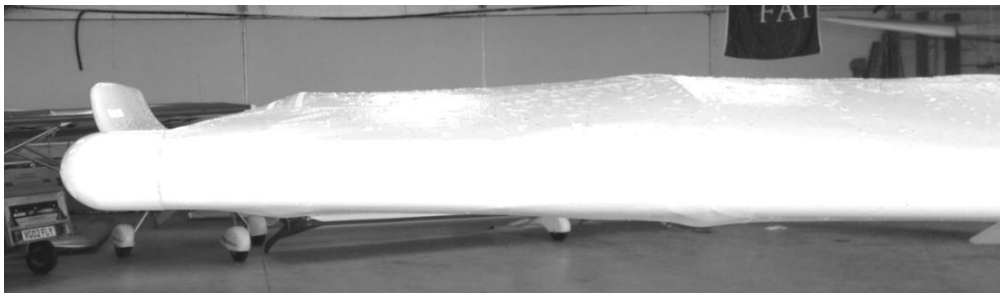




**Figure 178** prop tape over wing tip U-brackets to prevent chafe.

*If using Xlam coverings you can apply anti corrosion fluids such as ACF50 to all wing frame parts, and inside and outside the tubes, prior to covering. Waxoil inside the tubes can also be used but be sparing or weight will rise!*

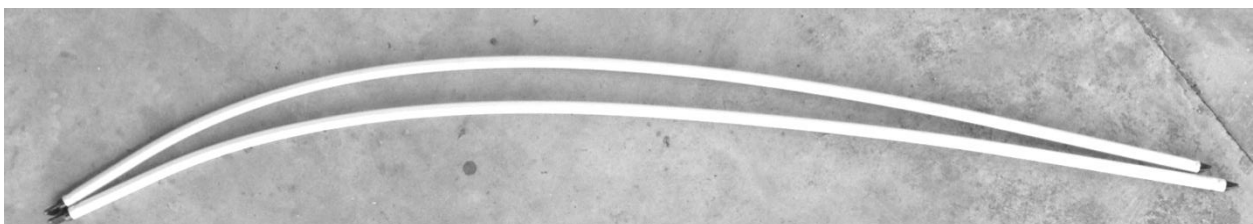
*The tip batten in Swift and Nynja wings has considerably less camber than the other battens due to the taper in depth of the wing as it approaches the tip.*



**Figure 179** wing tip

*The battens are supplied pre bent all the same size and camber and when inserted the tension springs them slightly flatter than the 'pre camber'. The tip batten has a significantly flatter profile than the others, and this batten must be flattened slightly before fitting.*

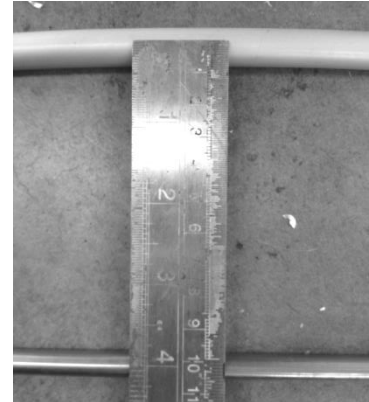
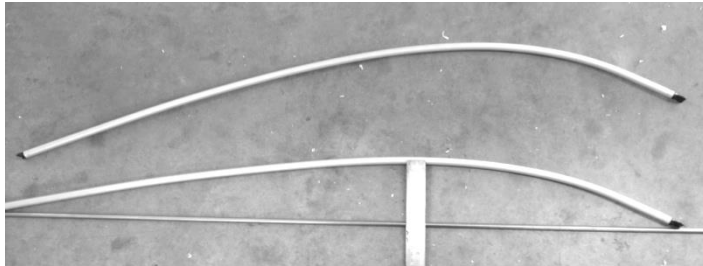
*Batten shape can be adjusted by gripping the batten firmly at each end whilst holding it upside down, then whilst kneeling, draw the batten across the extended knee whilst applying downwards pressure. Repeat whilst applying increasing pressure as required to flatten the camber.*



**Fig 180** normal and flattened battens

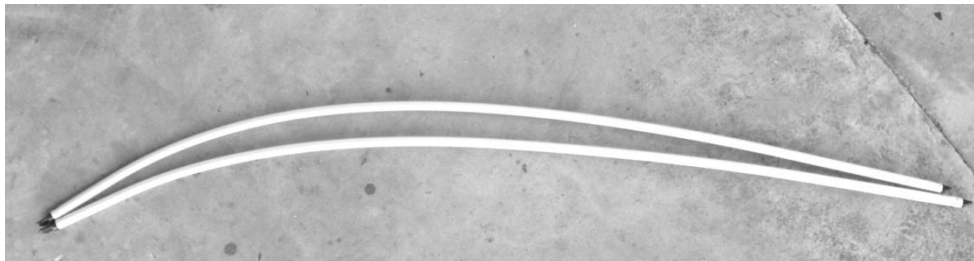
The above picture shows camber reduced for the tip batten compared to its starting shape. Camber has been reduced along its length. The forward section is hardest to flatten and may need considerable pressure.

Using a straight edge as shown below a guide for max depth of camber you are aiming for is 100mm from top of straight edge and middle of batten



**Figure 181 – measuring depth of peak camber**

Due to the tip batten having less camber than the others it causes the overall length to increase. This means it sticks just out of the end of the pocket. A cosmetic enhancement can be made by cutting the batten at the rear end by 13mm. Carefully cut around the circumference so as to cut the tube and not destroy the plastic batten end. Remove the end piece with the plastic end then cut across the remaining metal ‘collar’ to release the plastic end. Clean up the end of the batten with a file and re insert the plastic end. Align it to match the tip insert (90 degrees to camber) and fix in place by centre punching the side of the tube.



**Figure 182 – flatter batten grows!**

See above – tips are aligned and lower batten has ‘grown’ at rear end.

- h) Lay the wing cloth on the clean surface, next to the frame

*Take care when handling the coverings to keep your hands (and any tools etc. you may handle) clean at all times.*

- i) Remove the turnbuckle from the drag cable.

*Make sure that the cable with the turnbuckle is over the top of the fixed cable.*

- j) Remove the compression tubes **SKR38**, the innermost cross-tube in the wings.

- k) *Plastic stiffeners are supplied which should be slid in the root end of the leading edge pocket in the sail just so far as they are completely covered by the leading edge pocket. It can be done later but is easier to get in now. These just smooth the leading edge fabric in this inner bay which can otherwise wrinkle where the sail is pushed upwards over the head of the vertical bolt in the Leading edge.*
- l) Insert only the upper surface (curved) outermost (tip) batten, but leave an inch or two still poking out of the rear of the batten pocket.

*It will be found to be very tight if inserted later, with a risk of ripping the batten pocket.*



**Figure 183 slide the wing frame into the covering.**

- m) Collapse the wing frame using a scissor type motion so that it will slip easily into the fabric envelope of the wing, Figure 183.

*The trailing edge has the most fittings on it, so scissor the wing to insert the trailing edge first.*

- n) Slide the frame of the wing into the cloth taking care not to damage the fabric with any of the fittings attached to the frame.

*Keep track of the turnbuckle, tie a bit of string to it if necessary.*

- o) Use the same type of scissor motion to expand the frame back to its original shape.

*Make sure that the fittings for ailerons, and flaps, as well as the strut attachments, exit through their respective holes in the fabric.*

- p) Attach a small diameter cord (dyneema or similar) through the grommet on the leading edge so that you can use a timber bar to press against the leading edge of the frame to stretch the fabric into place, Figure 184.

*It will be tight and to get the leading edge to fully seat in the end of the sail you will need to use a lever and pry against the leading edge tube, being careful not to damage it. Note the piece of wood to protect the tube end in the photograph.*

*Check that the fabric is properly seated at the tips of the leading and trailing edges. It should be nice and snug, with no wrinkles near the tip. If prop tape or similar has been incorrectly used it is possible that it will grip the fabric and prevent it sliding down the leading edge, causing difficulties later.*



**Figure 184 pulling the fabric into place.**

- q) Tighten the bolts on the compression tubes **SKR38**.
- r) Install the compression tube **SKR38** by placing the end without the bolt over the round spacer on the trailing edge of the wing frame. Put the other end over the aluminium cam, and push the strut into place.

*The cam should pop straight when the tube is pushed into place. It may be necessary to apply a sharp tap, or to use a blunt screwdriver to push the cam straight. There is no need to bolt the cam in place.*

*Ensure that the two large holes on the compression tube are facing the fuselage end of the wing.*

*The leading and trailing edges will have to be spread apart to get the cam in the tube. Cut a piece of timber 1035mm long and insert one end up against the trailing edge spar and use the front sliding it along the leading edge to open up the gap. Use a piece of cloth between timber and spar to prevent scratching. Pop the cam in and then remove the wood.*



**Figure 185 fitting the compression tube.**

- s) Lay the wing flat on its lower surface. Give the leading edge rope a pull to ensure frame is snug in the tip of the sail.
- t) Replace the turnbuckle on the drag cable and tighten by hand until the other cable comes taught, which may require some effort.

*The cable with the turnbuckle goes over the other cable.*

*If the cable without the turnbuckle will not tighten up, check that the covering is properly seated along the leading edge.*

- u) Install the two large diameter battens (**SKR184** curved, **SKR185** straight) at the wing root end of the wing covering,

*They are inserted through the holes at the trailing edge of their pockets (look closely, they are there), not through the holes further forwards.*

*Push the battens in as far as they will go and slip them into the wing root side of the pocket so that they are held securely in place.*

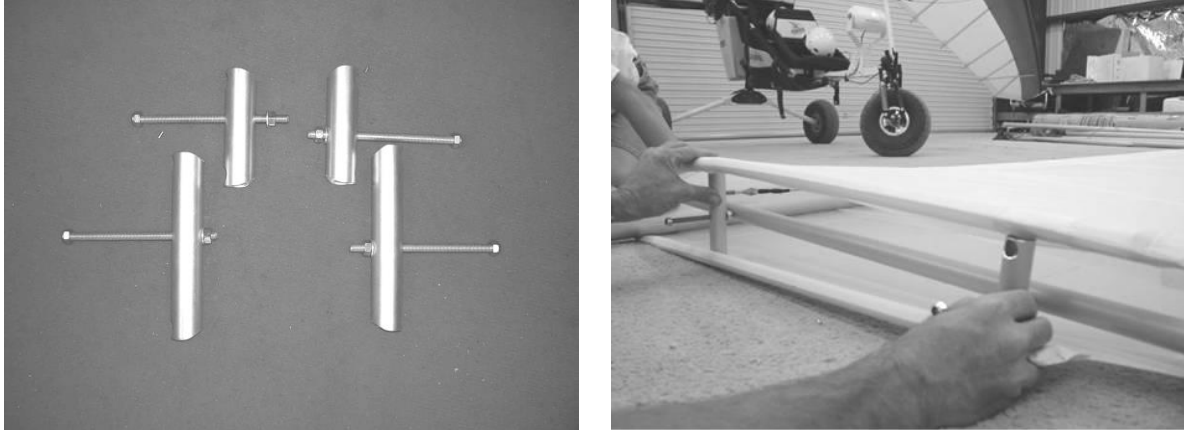


**Figure 186 large diameter wing root battens.**

- v) Install the two wing tensioning tubes (**SKR32** and **SKR33**) against the outboard side of the large diameter battens.

*Cut the ends of the tensioning tubes at an angle, on the sides opposite the holes, and finish them nicely. This prevents them cutting into the fabric.*

*They will fit into the holes cut in the fabric for this purpose. The longer end of the tensioning tubes goes uppermost. The holes cut into these tubes must clip over the battens, and the threaded rod must enter the holes in the compression tube, figure 187*

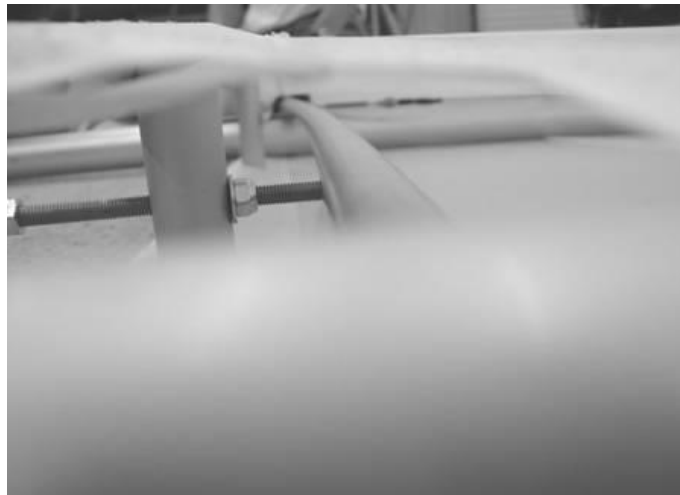


**Figure 187 tensioning tubes.**

- w) Tighten the wing tensioning tubes against the compression tube by turning the threaded rod.

*To turn a threaded rod, put two nuts on the end and tighten against each other. Turn the rod with a spanner on the outermost nut, whilst holding the nut behind the tensioning tube with another spanner.*

*The threaded rod will push against the compression tube and tension the fabric.*



**Figure 188 compression tube bowing.**

- x) Tension the fabric to the point that you see the compression tube bowing, Figure 188.

*There should be around a 4cm gap between the compression tube and the vertical wing tensioning tubes.*

*This should result in the bow in the compression tube being no more than the diameter of the compression tube. You can check by placing a straight edge along the compression tube and measuring the space in between.*

- y) Check that the cables in the wing are still taught, tighten if necessary, then secure the turnbuckle with safety wire.

- z) Use the rope that you have attached to the leading edge of the fabric to pull the fabric tight in the same manner as before.

*Look for the wrinkles just near the leading edge-root section of the wing. Tension the fabric with the rope until you see these wrinkles pull out. This will require a good firm pull.*

- aa) Whilst holding the tension on drill a hole through the centre of the grommet and secure the fabric in place with a 4mm or larger steel rivet and a washer.

*Alternatively a stainless steel countersunk screw can be used.*

*Add blob of grease in the grommet before fitting the rivet/ screw. This will help protect against corrosion.*

*Remove the string before the final rivet pull or screw turn.*

- bb) Leave a nut on the end of the threaded tensioning rods and cut off the remaining thread, then finish nicely with a file.

- cc) Measure the distance from the fabric to the end of the leading edge and make both wings the same, otherwise it will look odd when aligned with the cabin doors.

*A typical measurement is around 44cm.*

## 8.7 Inserting the Battens

- a) Make sure the wing battens are clean, and insert them into the fabric to the point where their rear ends still sit on the trailing edge tube.

*Get someone to steady the wing.*

*Start with the upper surface battens first. Begin at the tip and work your way toward the root.*

*Do not let the battens twist, use two hands.*

*Use one smooth motion to insert the batten all the way into the wing. Stopping in the middle can cause the batten pocket to rip when you try to continue.*

*Wear a glove on your pushing hand.*



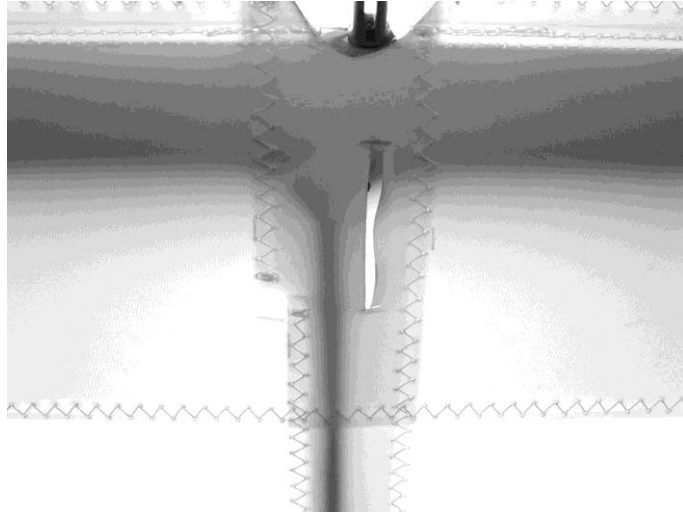
**Figure 161 inserting a batten. Use your other hand to prevent the batten twisting.**

- b) Once each wing batten is in place, use a screwdriver to push fully home, slip the fabric flap over the end of the batten, then slide the batten sideways into the pocket in order to secure it in position.



**Figure 166 secure the battens in position.**





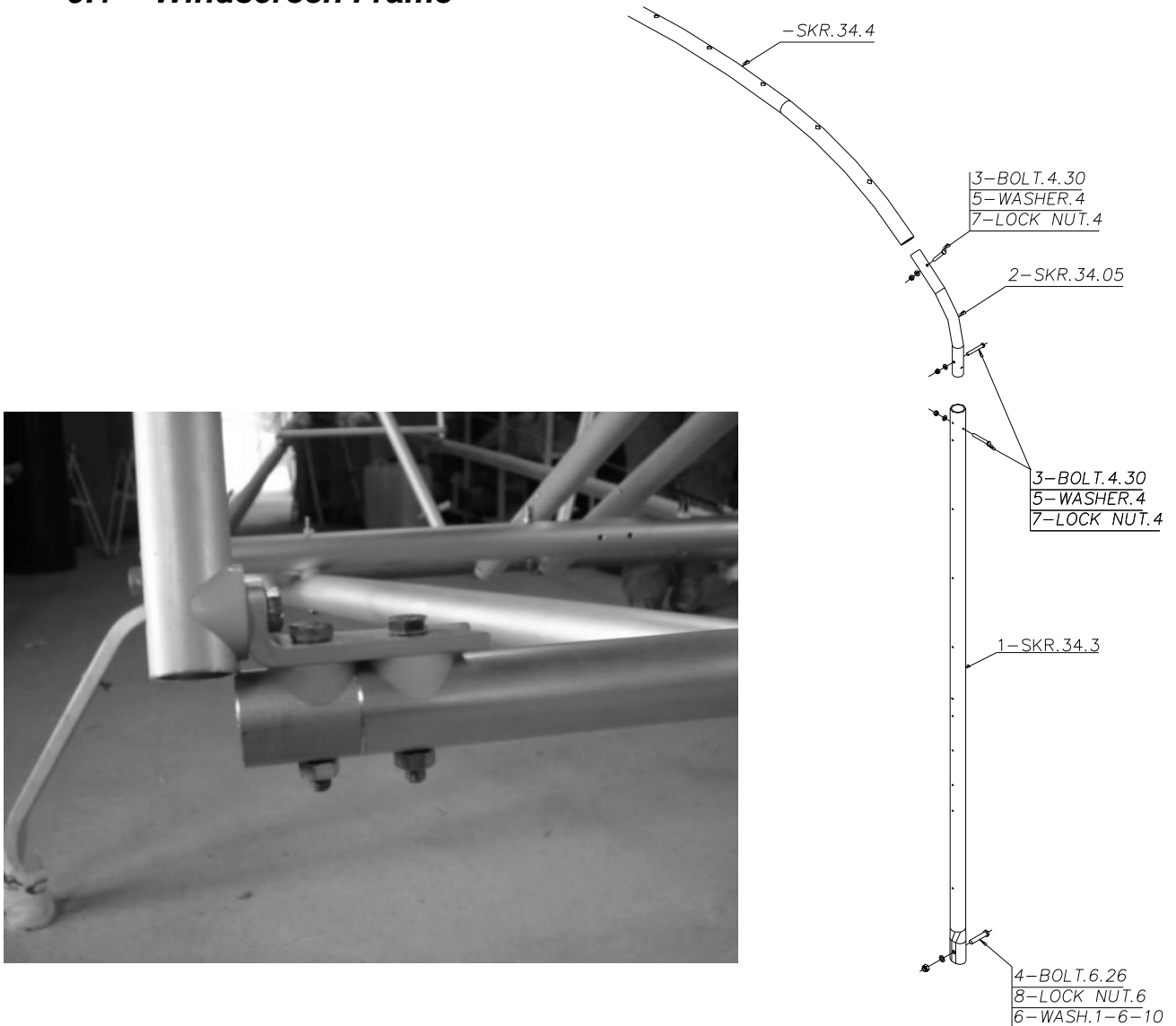
**Figure 167 batten end.**

- c) Next do the same with the lower surface battens.
- d) After the fabric has settled for a few weeks, any remaining minor wrinkles can be taken out using a heat gun to shrink the fabric. Great care must be taken not to burn the fabric!

## 9. Windscreen Frame

Before mounting the cowlings and firewall, the windscreen support frames should be installed. These parts position the rear edge of the cowlings.

### 9.1 Windscreen Frame



**Figure 168 cabin uprights ( note that saddle washer shown may be superseded by flattened tube sides and 1mm plastic washer should then be used).**

- Attach the bottom of the cabin uprights **SKR34** to the outer edges of the rudder pedal mounting bar as shown above. Note that the bolt fixing the lower bracket to the upright tube **SKR34** has the nut and washer inside the tube. The thread will be too long as supplied and need trimming to be short enough. The vertical bolts also pass through the floor (omitted from this picture above for clarity), and the outer one each side should have a penny washer under the nut to spread the load into the floor without crushing.

- b) At the rear of the **SKR34** support frame, the tubes are flattened slightly and fit onto the bolt end protruding upwards from the fuselage at the trailing edge attachments.



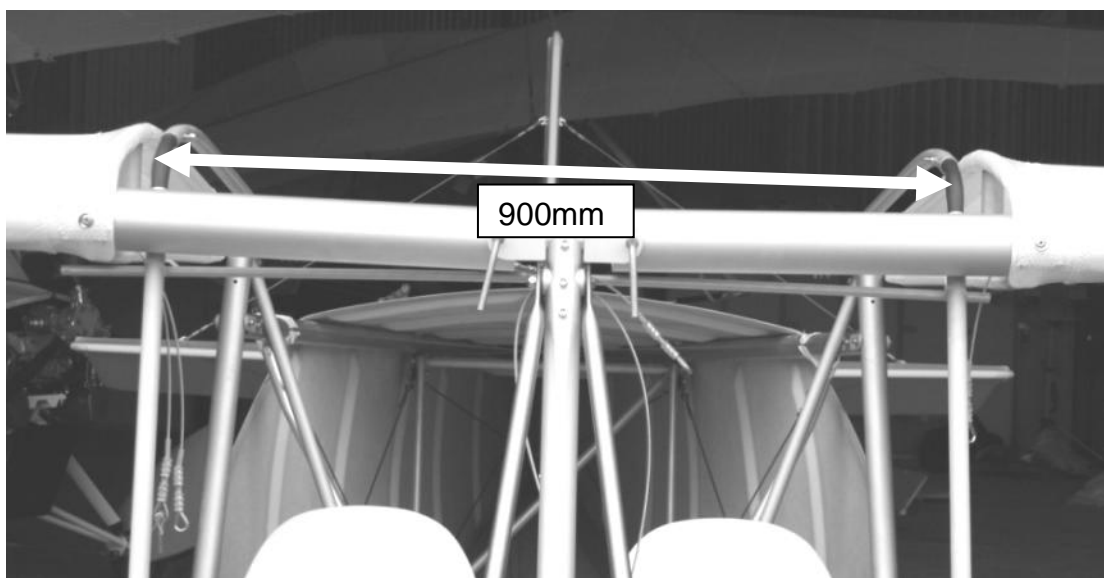
**Figure 169** Rear ends of windscreen support frame

- c) Slip one of the large diameter heat-shrink rings over each leading edge, and fit the covered wings to the fuselage.
- d) Ensure that the **SKR34** tubes fit behind the leading edge with around 3-5mm of clearance, and that the curves of the top tubes match the curve of the large innermost wing battens, to get a good fit between the Lexan windscreen and the wing.

*Use a long straight edge for this. It may be necessary to tweak the stainless steel curved piece which joins the upright tubes to the curved upper tubes, slide it up or down inside the vertical and curved tubes to get the best position, and to re-drill the holes which secure it.*

*In the correct position the tubes should be centred, with the centres of the tops of the tubes around 900mm apart, so that the upper curved tubes are run parallel back to the rear attachments.*

*The cabin uprights will then lean slightly outwards from their bases.*

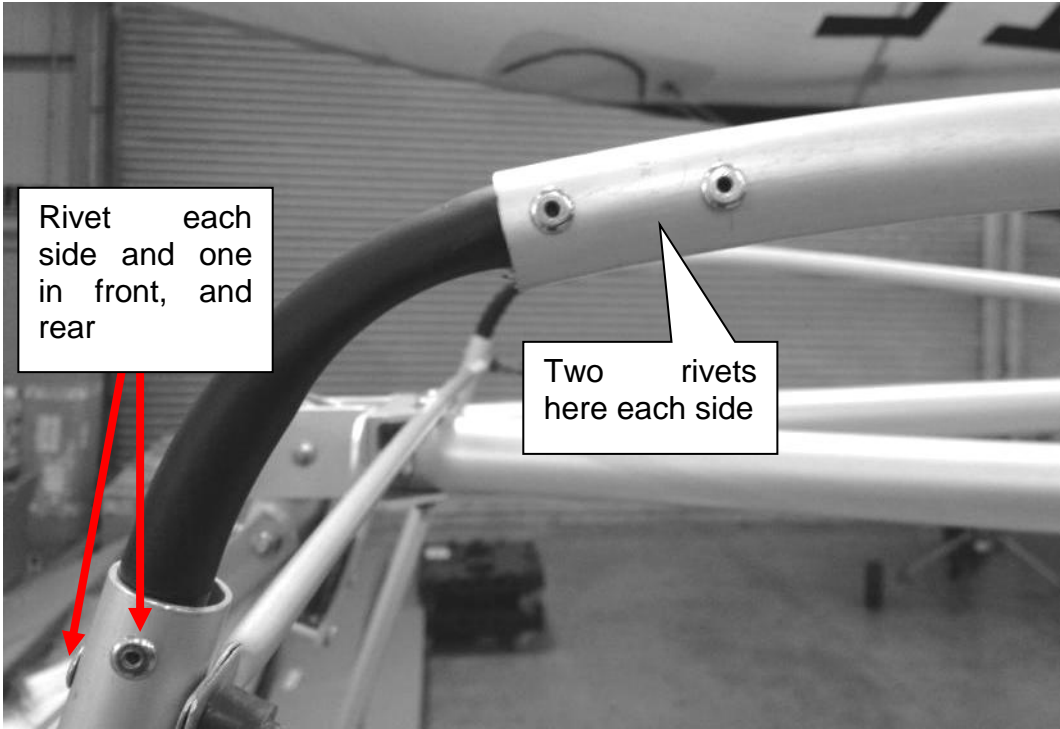


**Figure 170** Position TU34 uprights 900mm apart



**Figure 171 left – Check cabin roof tubes align with wing – level or slightly above. Right – check there is a gap of around 3-5mm here.**

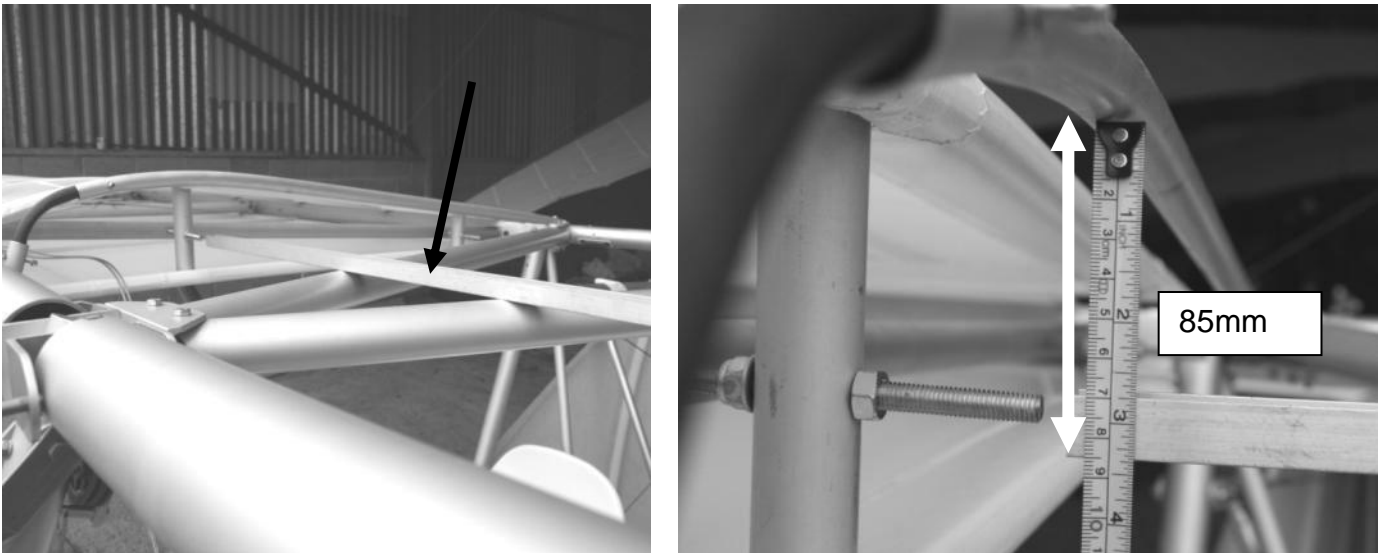
Rather than use the bolts to secure the stainless steel curved pieces, we recommend 4x10mm steel rivets spaced as shown below with the aim to secure and prevent any fore / aft movement of the TU34 upright tube which may close the gap to the leading edge tube once the weight of the cowling is on them.



**Figure 172 – stabilising with rivets**

- e) It really is a good idea to have the wings covered and fitted to verify the position of the SKR34's as shown above. If for pressing logistic reasons the wings can't be constructed and fitted at this time it is possible to check fit using the measurement method as shown in fig 168 below.

If it checks out without adjustment it should be ok to proceed. If it needs adjustment then wings will have to be fitted as gap from uprights to pass behind leading edge may not be guaranteed.



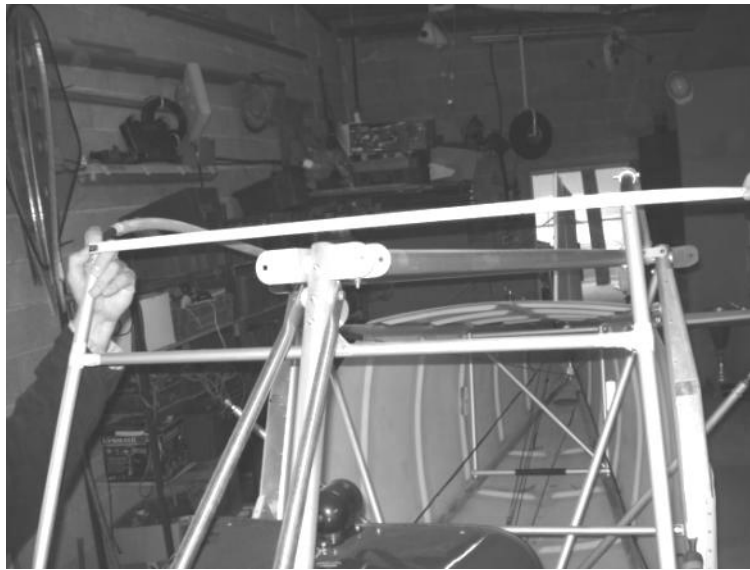
**Figure 173 straight edge across cabin upper tubes. Measurement of 85mm from under tube to straight edge at point of max camber**



**Figure 174 match up with wing so clear roof section will later fit flush like this**

- f) Measure the positions of the **SKR34** tubes relative to the centre of the aircraft to verify they are still at 900mm
- g) Mark the positions for the heat-shrink rings to centre them on the **SKR34** tubes.
- h) Remove the wings, and heat-shrink the rings into position.
- i) Secure the **SKR34** tubes at the same positions they held whilst the wing was fitted.

*These can be held in place simply by a tube, such as a piece of plastic drainpipe or similar and cable ties / tape. Or a more 'engineered' system using aluminium tube and brackets. The aim is to securely locate the tubes.*



**Figure 175 measuring and holding the frame in position.**

## 10. Floor pan, firewall and cowlings

### 10.1 Floor pan

With the cabin uprights in place we can now fit the glassfibre floor pan panel.

- Trim to the cut marks to fit around the main undercarriage legs then offer up in position, after first removing the flap detent lever.
- Hold up in position using cardboard boxes or similar and clamps on the sides. Verify correct positioning by reference to the underneath rear edge where it joins the rear fuselage shells, and the cabin uprights – see figures below:



Figure 176 rear edge

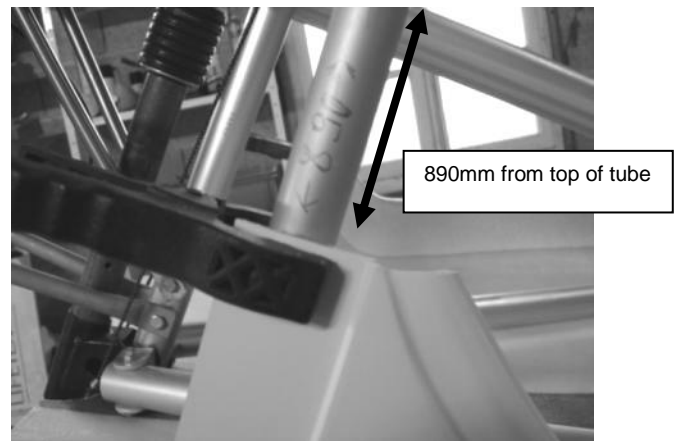


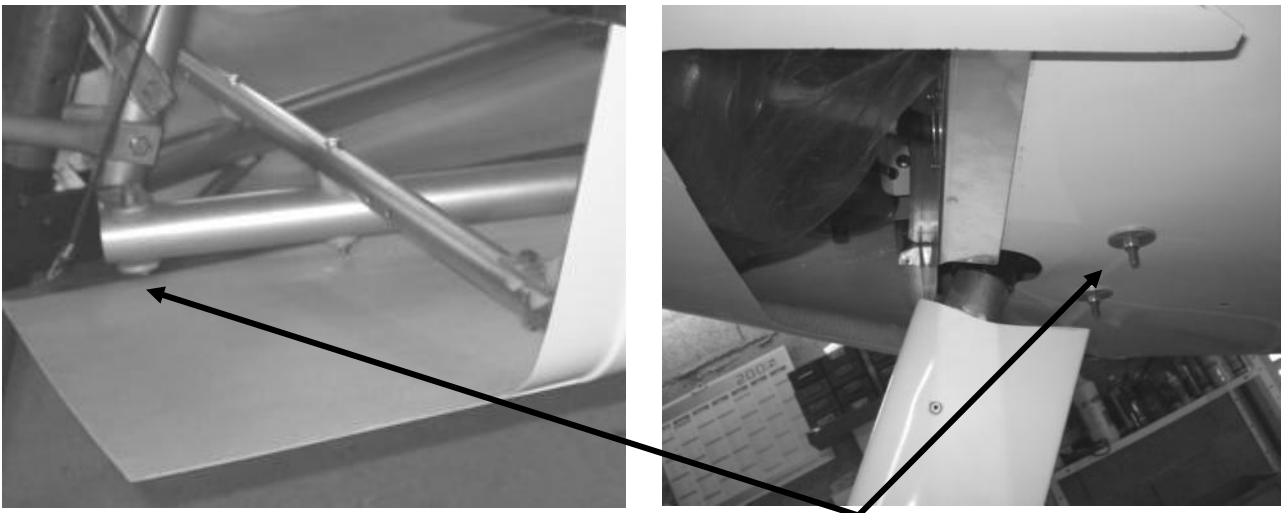
Figure 178 forward positioning

- Note in figure 177 above, the joggled edge should be aligned just behind the rear face of the cabin upright tube. Note also the vertical positioning – guide height 890mm below top of cabin upright tube. The lower rear edge may need some dressing with a sanding block and 80 grit paper to achieve a nice even fit.
- Check the rear sides and ensure overlap or alignment with joggled edge of rear fuselage shells. See Fig 178 below



**Figure 179 rear overlap**

- e) When happy with the positioning fix first using the two bolts that connect the TU12 tubes to their U brackets – see fig 184 below.



**Figure 180 fixing at front**

- f) Use 3mm plastic washers under and over the floor panel followed by a steel penny washer before the nut on each of the forward fixing points
- g) Drill and fix the rear under floor edge with Clecos/ Skinpins starting from the middle and with spacing around 80mm.
- h) Offer up the sides and mark and cut so the edge aligns neatly with the joggle in the rear fuselage shells.

*Use a Dremel cutting wheel, or a fine hacksaw blade worked at a fine angle. Finish with a sanding block to get a nice smooth line with good alignment.*





**Fig 181 mark cut line**

- i) When happy with fit drill and fix in place with white aluminium 4mm rivets. Evenly spaced at 65mm or so.

*Fix initially with clecos then ensure all swarf is removed before final riveting.*



**Fig 182 final fixing**

- j) Fix the front to the door pillar tubes (SKR34) using three 4mm aluminium rivets each side.

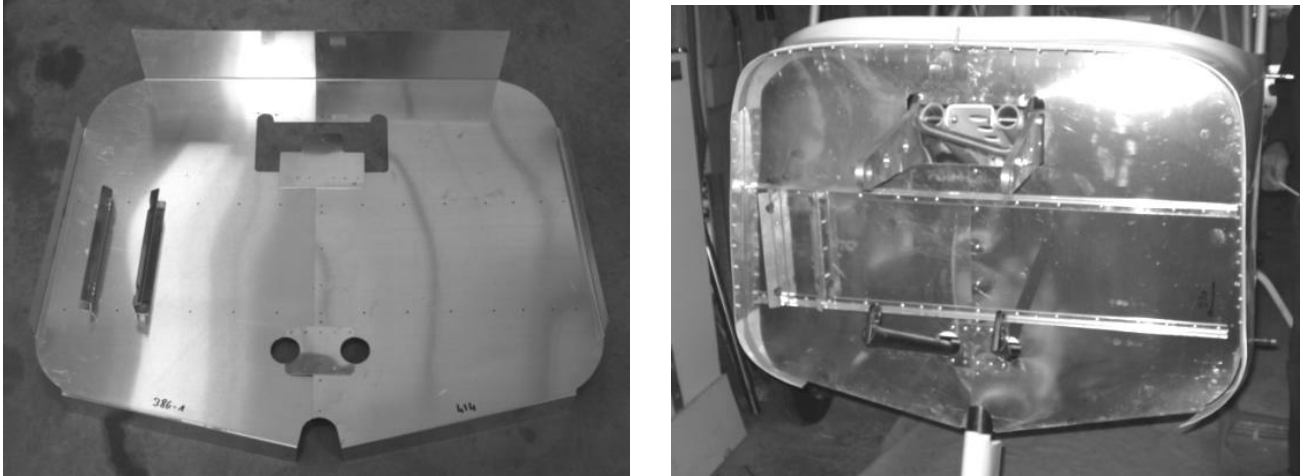
*Countersink the rivets using a 10mm drill bit to countersink the glassfibre so the rivets sit flush.*

- k) Fix the rear edge with 4x10 white plastic screws and self locking plastic nuts.

- l) Cut slot in floor to allow flap detent lever to pass through – see Figure 181

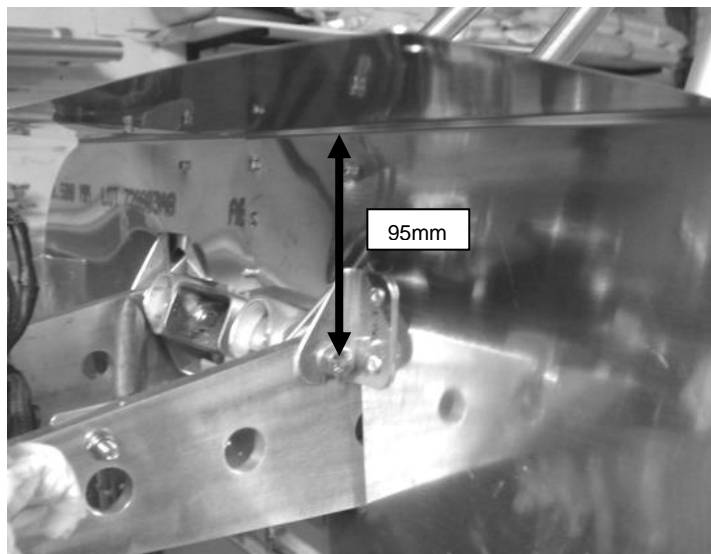
## 10.2 Firewall and scuttle moulding

Next steps are to position the firewall and scuttle moulding before assembling the forward cowling pieces.



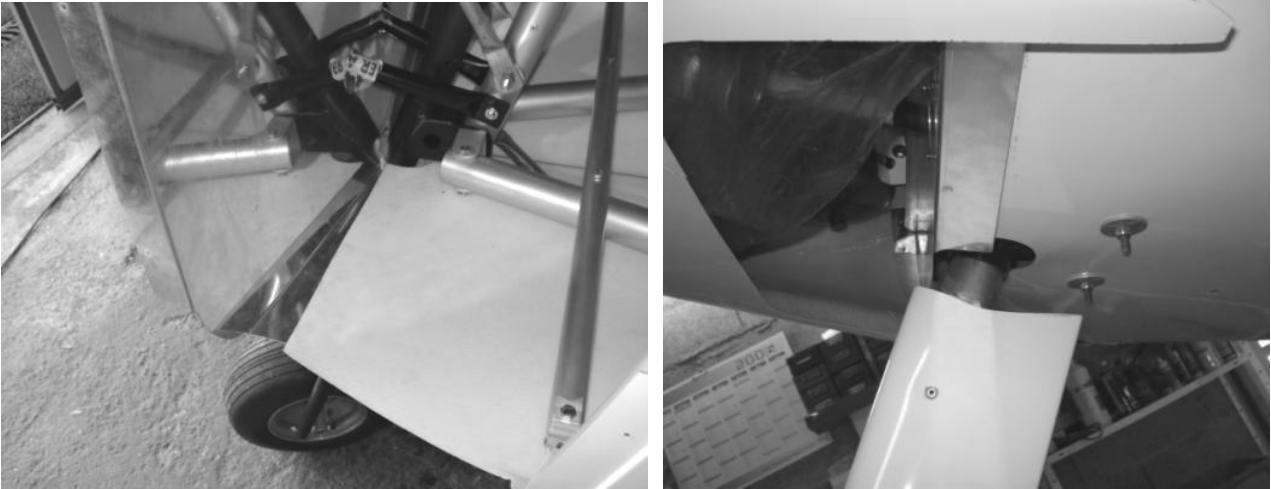
**Fig 183 Firewall components, and installed firewall (engine removed for clarity)**

- a) Fit the firewall halves in position behind the engine. Attach the two halves using cleco's / skinpins for initially fitting. *The holes in the firewall are supplied pilot drilled and will need opening up to 4mm. Do this before fitting as access to drill behind the engine might be difficult.*
- b) Firewall should fit in position as shown below. Firewall should sit behind the reference bolt shown and top edge should be 95mm above its centre. *Attach the small rubber edging to the edges of the cut outs where it sits in close proximity to the fuselage frame. If necessary file the cut outs to give space for this so position is maintained. Fix into position using the small angle brackets using 4mm steel rivets with 4mm washers on the back side. If the heater option is to be fitted it may be easier to cut the hole for it and trial fit before fixing the firewall.*



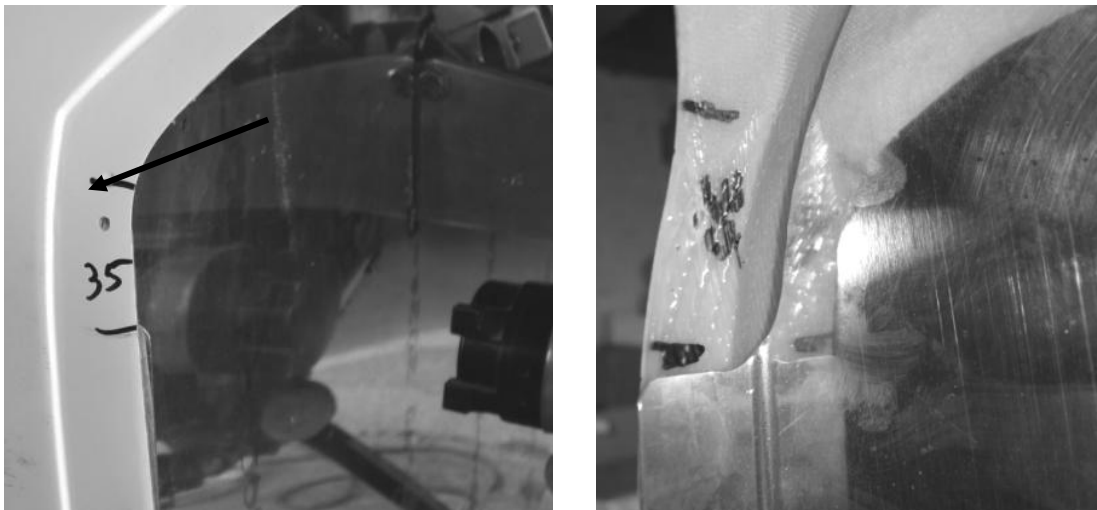
**Figure 184 position and fixing of firewall to engine mount**

- c) Lower edge of firewall sits under the floor plan as shown below don't fix at this stage.



**Figure 185 position of lower edge of firewall**

- d) Fit scuttle moulding in position. It can be fixed to the firewall sides in the position shown below. *The photo shows a reference mark in the moulding (illustrated by the arrow). Firewall top edge should be positioned 35mm below this mark as shown.*



**Figure 186 position of firewall relative to scuttle moulding**

- e) Fix the firewall edges to the scuttle – using 3mm countersunk rivets. Use just one top and one bottom each side for now (*the rest will be fitted when the exact position of the cowling screws are determined to ensure even spacing*) Drill a 3mm hole. Then take a 10mm drill bit and apply light pressure to contersink the glassfibre until the rivet head sits flush..
- f) Move now to the top edge of the firewall. This is fixed to the upper forward edge of the scuttle. *The outer edges will need bending downwards in a slight curve to match the curve of the moulding. This can be done with some light hand pressure. The aluminium will also need trimming to match the edge of the moulding. When happy with the fit fix using 3mm countersunk rivets. Use just two for now 50mm either side of the dead centre. The rest will be fitted when*

*the exact position of the cowling screws are determined to ensure even spacing.*

- g) Dont trim or fix the scuttle to the door pillars just yet as some final adjustment will be required to ensure perfect alignment of cowlings and spinner,. Hold it in position for now with some tape and clamps in the position shown below



**Figure 187 scuttle positioning – dont trim overlap yet, and clamp in position with upper edge around 500mm from top of door pillar tube (TU34 (note – some sanding of top edge of scuttle may be necessary to acheive a symmetrical measurement – and may not be exactly 500mm).**

- h) Firewall halves can be rivetted in position now (short 4mm bolts can alternatively be used if desired), and the small closure panels can be rivetted in position now or left until engine ancillaries are all fitted – dont forget them!



**Figure 188 left - firewall closure panels – dont forget them! right - sealing**

- i) Firewall Foam – this is self adhesive on one side and is fire retardent and noise dampening. It is applied to the cockpit side of firewall. It can be done at this early stage or applied near to finish of build. Further sealing grommets can be fitted if desired as in fig above – use non flammable material such as leather etc.

### 10.3 Engine cowlings

- a) Assemble the two cowling parts. Offer up first and verify that the two parts fit snugly together. Some sanding on the edges may be necessary for a perfect fit. When happy and initially held together with tape, carefully drill the fixing holes. There should be guide marks, but if these are not present or very faint, start by drilling a forward hole each side 30mm outboard from the position where the cowling changes angle as shown below, and 10mm up from the upper cowling edge.

Cleco / Skinpin together, then mark the other holes starting with the rear one, which should be 50mm forward of the rear edge. Then mark the remaining 3 holes (5 in total) with even spacing (this will be approximately 170mm). Drill and fix with Clecos/Skinpins or 4mm nuts and bolts. Starting from the front and working backwards will give the best results with less chance of bulging between fixings.

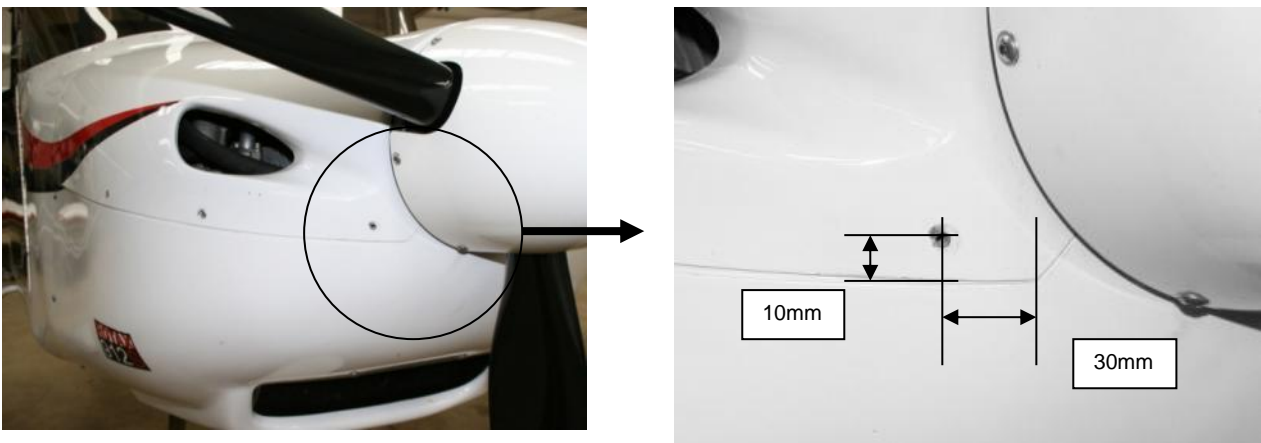


Figure 189 front cowling fixing

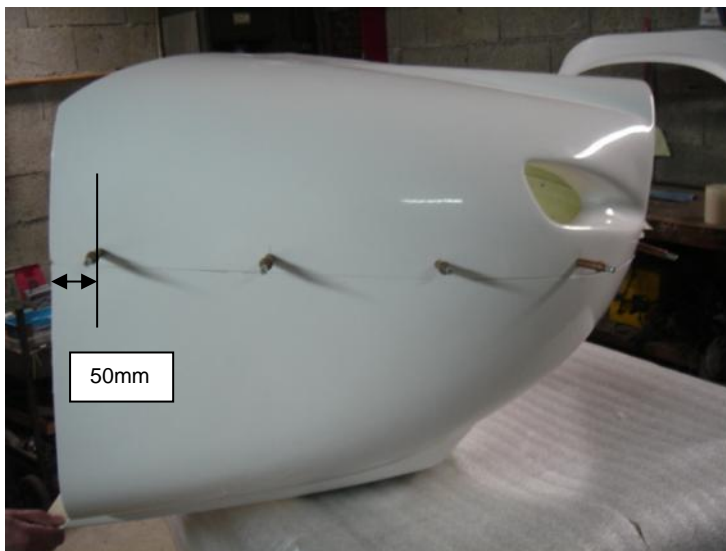
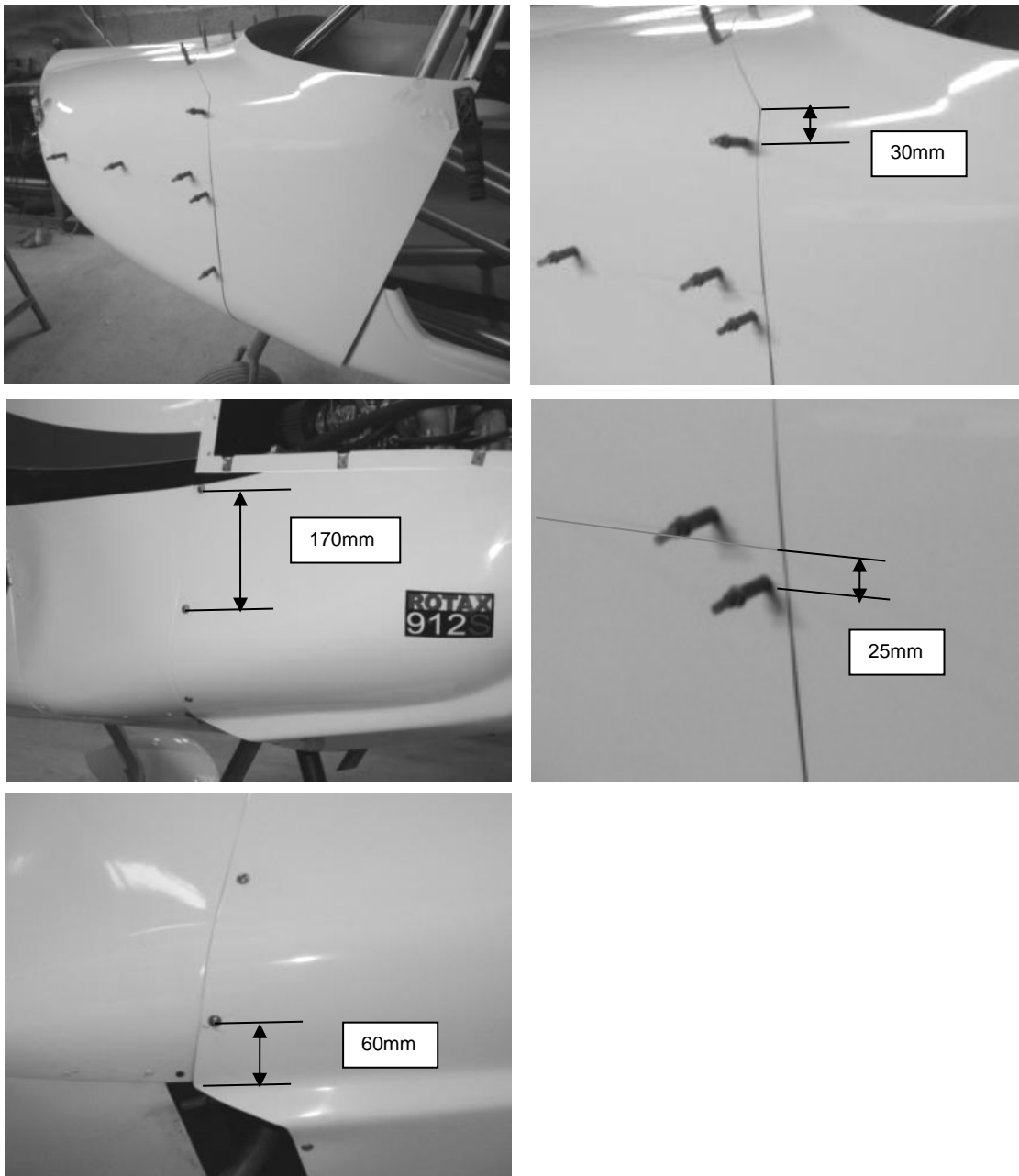


Figure 190 position and spacing of fixings on side of cowling

- b) Next fix the cowling parts to the scuttle moulding. Offer up first and verify that the two parts fit snugly together. Some sanding on the edges may be necessary for a perfect fit.

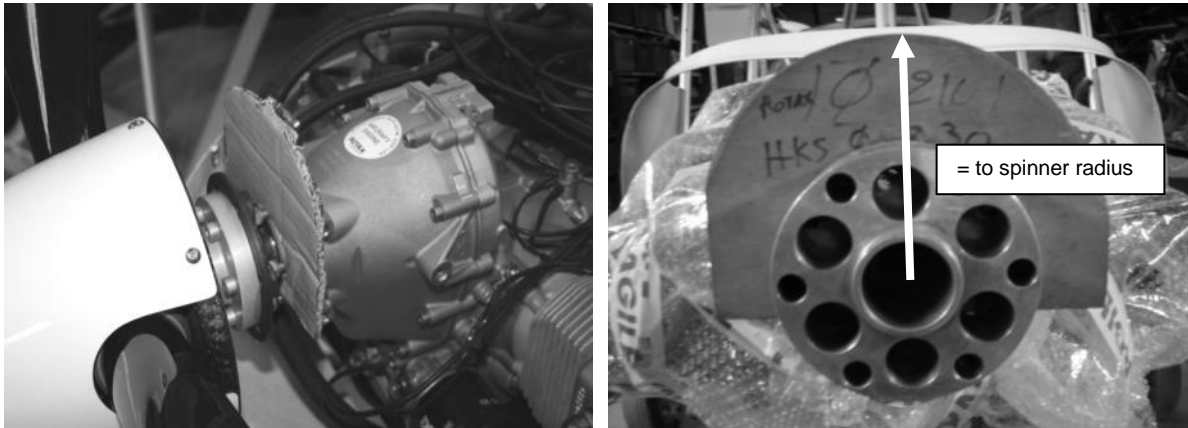
There should be 7 fixings across the rear of the upper cowling part. Start with one in the centre and one on the outside 30mm from the angle change as shown below. The others should be evenly spaced from the centre (approx 140/150mm apart).

The lower cowling has three fixings each side. Start with the upper one 25mm below the joggled edge. Next one 170mm below that and the final one underneath the curve 60mm from the final edge.

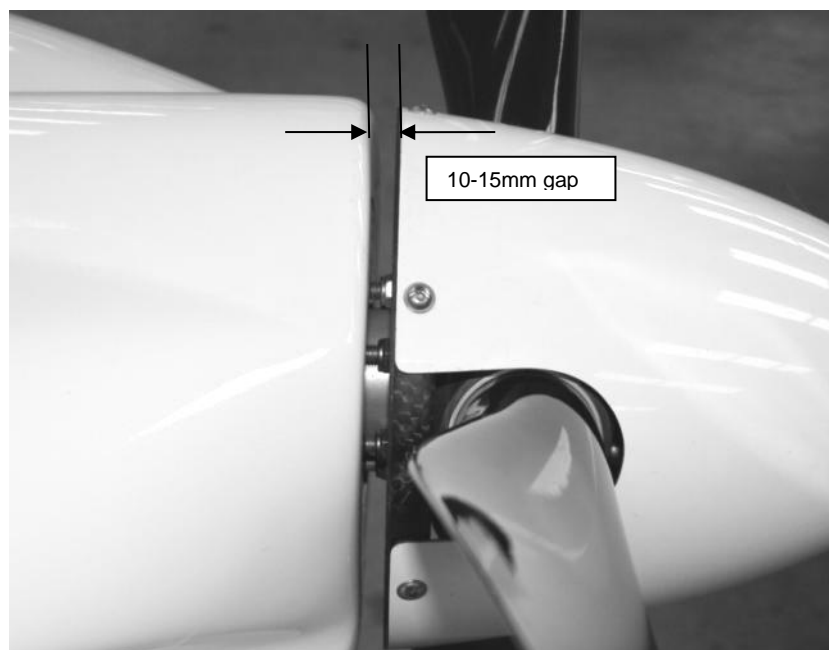


**Figure 191** fixing the cowlings to the scuttle (note cowling may now be supplied with moulded vent holes in lower sides, adjust position of fixing holes accordingly).

- c) With cowlings all attached and aligned with each other satisfactorily the holes can be opened up to 5mm and the captive nut cowling clips slid over into position. Cowlings can then be attached with the 5mm cowling bolts. Alternatively if quick release fasteners are to be fitted they can be fitted now, or later. If later make sure you have enough Cleco's / skinpins or small nuts and bolts to fix all cowling pieces together firmly – which will be required during the next steps.
- d) Cowlings need to be aligned with the spinner (*note that cowlings are made for spinners of around 20 -23cm diameter – alignment with larger or smaller ones may not be possible*). The UK standard fit is a 40mm prop spacer and Kievprop 23cm diameter spinner. Fit these at this stage. Then lift the front of the cowling to align. To hold this position make a support out of some wood sheet or stout cardboard as shown below. The support should be a similar diameter to the spinner.



**Figure 192 cowling support - horseshoe shaped to fit behind engine drive flange.**



**Figure 193 spinner / cowling alignment**

- e) Adjust support height so that cowling aligns with spinner. *Set it a little high by 5mm or so to allow for a slight sag when support is removed after scuttle is fixed. Cowlings should sit with around a 10-20mm gap to the spinner edge. This can be adjusted over a small range by pulling forwards or backwards with the clamps holding the scuttle to the door pillars loosened. Likewise the cowling can be adjusted side to side.*
- f) Verify that the scuttle is in the correct vertical position – 500mm below the top of the door pillar tubes +/- 20mm or so as required to get good fit and alignment for it to wrap into the correct position on the floor pan.

With all cowling pieces firmly attached to each other with cleco's / skinpins/ bolts, or final cowling fasteners do a final verification that all alignment is good. When completely happy drill through the scuttle to fix it to the door pillar tubes. *Use a 4mm drill and fix with Clecos/Skinpins as you go. Check alignment hasn't shifted before drilling each hole.*

*Mark and trim the rear edge of the scuttle to align with the joggle in the floor pan and follow up parallel with the door pillar tube. Sand to finish – taking care not to damage the tube – protect with tape or similar.*

*Note – if fitting two piece doors, before drilling and fixing, fit in place the door hinge to ensure complimentary spacing of holes. If fitting one piece doors you may wish to use the galssfibre strip to provide a sealing edge. This should be fitted now also – look ahead to door instructions at this stage.*

*We used 60mm spacing between fixing holes. The picture below shows a rather larger spacing – you decide!*

*Final fixing is done with white 4mm aluminium rivets.*



**Figure 194 fixing the rear of the scuttle**

- g) Fix the firewall to the floor. *Use 6 x 4mm rivets each side of centre with a spacing of around 50mm – don't fit the outer rivets just yet.*





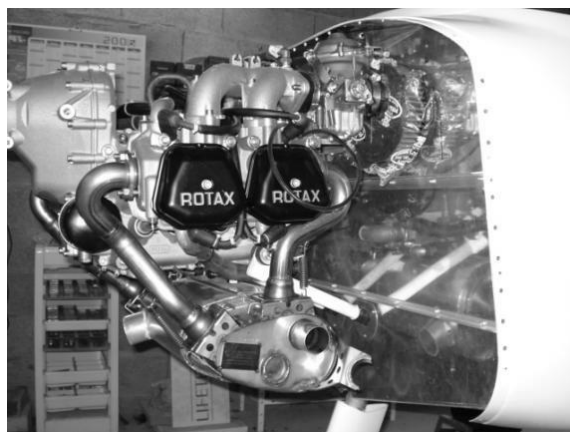
**Figure 195 fixing lower edge of firewall to floor pan**

- h) Fix the lower sides of the scuttle to the floor. *Use 4mm white rivets. Some trimming will be required to get a nice smooth fit. Gentle warming with a heat gun may make wrapping the scuttle edges into position easier.*



**Figure 196 fixing lower edges of Scuttle moulding**

- i) Remove cowlings at this stage, and finish fixing side and top firewall edges to scuttle. *Use the 3mm countersunk rivets, with a spacing of around 50mm evenly arranged around the holes for the cowling fixings.*



**Figure 197 finishing fixing firewall**

- j) All exposed glassfibre within the engine compartment must be painted with the supplied intumescent paint to give them fire resistance.

## 11. Engine Ancillaries

### 11.1 CKT twin outlet exhaust fitting

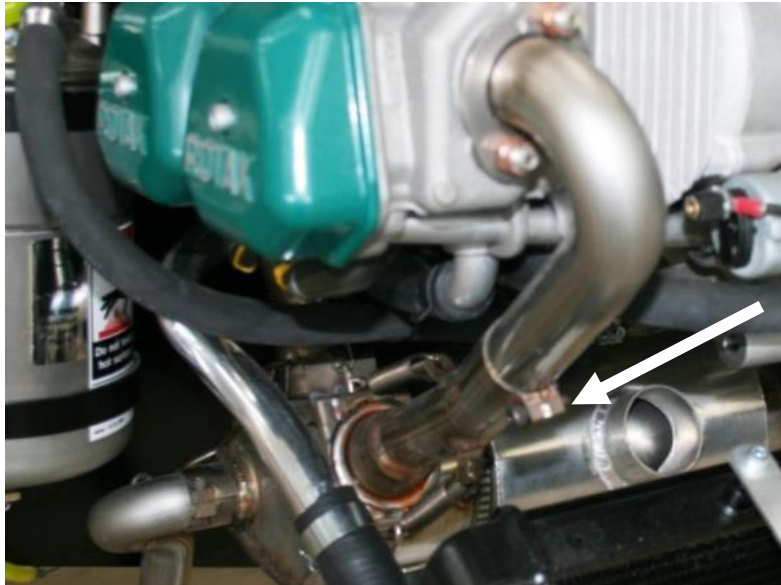


Figure 198 – exhaust in position and with heater jacket

- a) If fitted with the heater option check the aluminium heater jacket is in position and clamps are tight.  
*Some blobs of high temp silicon applied across the clamp strap every few inches, and the tightening bolt threads is a good idea to stop loosening and movement in service.*
- b) Insert the exhaust pipes into the muffler and secure with springs.  
*A touch of Copaslip high temperature grease should be applied to the ball joint ends of the exhaust pipes.*  
*Use string to pull the springs on, not pliers which can scratch and severely weaken the springs.*
- c) Offer the exhaust up to the engine and bolt on loosely.  
*Note - do NOT use Copaslip on the connection between pipes and cylinder head.*
- d) Centre the muffler side-to-side by reference to the engine mounts and the ridges on the muffler.  
*Note the oil line fitting is off-centre.*
- e) Tighten up the exhaust mounting bolts. Tighten until there is very slight distortion visible in the flanges.

- f) The front Starboard pipe incorporates a sliding joint. Leave tightening this pipe until last. Before fully tightening the bolts, slacken the clamp and adjust the length so that all four pipes fit evenly into the exhaust.

*If this pipe is adjusted too short the front starboard and rear port pipes will not seal properly and if too long the front port and rear starboard pipes will not seal properly. This will result in an exhaust blow or 'tick'. When happy with the fit tighten the mounting bolts and the clamping bolt. Do a final check with a good firm 'wobble' - you should not be able to see/ feel any uneven seating.*



**Figure 199 Port front pipe, showing clamp on sliding section**

- g) Fit the twin outlet pipes. Adjust their position so they are clear of the firewall by approximately 20mm, then tighten. Lockwire between the safety loops (this is to prevent loss of a pipe if the clamping comes loose for some reason).



**Figure 200 overview from port side.**

## 11.2 Oil cooling

Note that the engine may contain some oil, be prepared for this when removing caps etc. Ensure that all oil hoses are properly rated for use within an engine compartment if not using the hose supplied by Rotax / Flylight.

- a) Fix the oil tank mounting brackets on the firewall with 4mm aluminium rivets. Pilot holes are pre drilled in the firewall for this. Then fix the oil tank to the brackets using the two large diameter 'jubilee' type clips. *There are two rows of holes running laterally across the firewall at the top and bottom of the brackets. These can be used to fix 2 strips of L section to stiffen the firewall. The Uk firewall spec is thicker than the prototype so these are not necessary, but are supplied in the kit – your choice!*

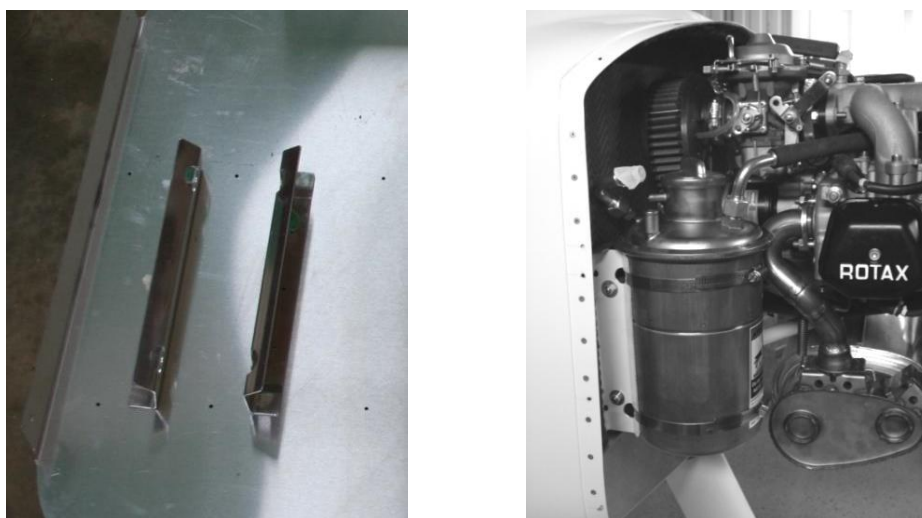


Figure 201 Oil tank mounting

- b) The oil cooler 'piggybacks' behind the water radiator, and attaches to it with two brackets. The water radiator itself fixes to the cowling with 4 brackets attached to the 4 mounting lugs on the radiator.

*Loosely fit the attachment brackets to the Water Radiator. The right angle brackets fit on the top and the acute angle brackets the bottom then the oil cooler brackets go over the outside of these – as shown below.*

*Then position the oil cooler so its lower edge is in line and parallel to the lower edge of the coolant radiator. Mark the brackets for reference.*



Figure 202 water radiator with brackets fitted, and with oil cooler in position.

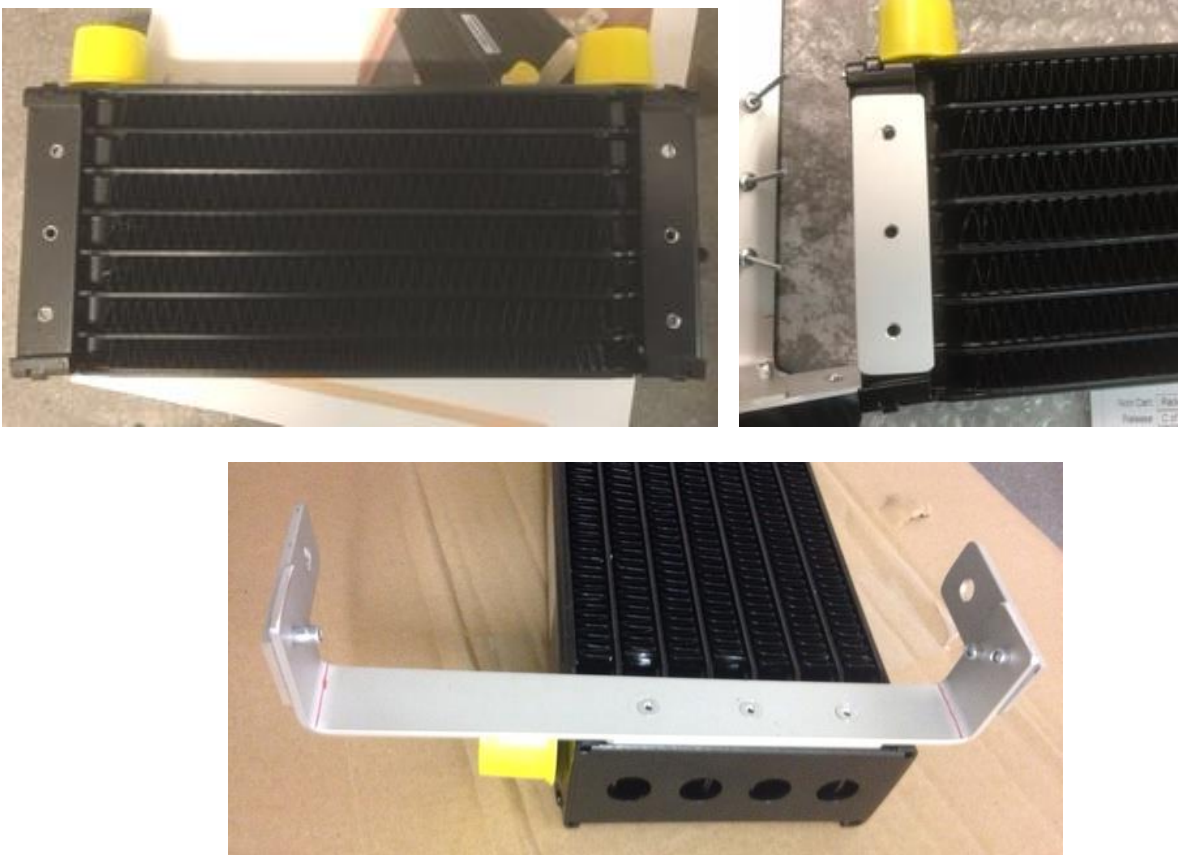
*Remove the brackets and drill them for 3.2mm rivets so that the holes align with the suitable area on the oil cooler between the galleries as shown below.*

*Drill the Oil cooler to match.*

*A spacer strip is used between the brackets and Oil cooler – this should be drilled to match also.*

*De-burr and using 3.2 x8 steel rivets, rivet the brackets to the oil cooler.*

*The oil cooler can then be attached to the coolant radiator. Ensure there is clearance between the rivet heads and the coolant radiator fins. The brackets can be bent a little if necessary to help this. Some self adhesive foam rubber can be applied to the bracket if clearance is tight to avoid any abrasion.*



**Figure 203 drilling and fixing the oil cooler to the brackets.**

- c) The water / oil radiator pair attaches to the lower cowling.

*The lip in the opening as supplied is quite large and must be cut right back using a Dremel or similar for the radiator to sit nicely on its brackets without interference. One correct position has been determined mark and drill 5mm. Attach to the cowling with 5mm pan-head bolts.*



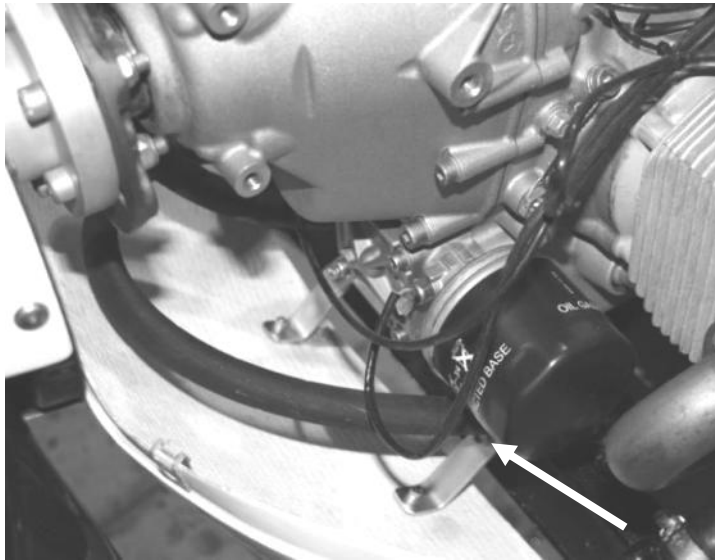
**Figure 204 radiator position and attachment**

- d) With cowling in position. Check clearance from oil cooler to the heater jacket intake on the exhaust. Cut this back as required to ensure a 10mm or so gap. Install the hose from the port side of the oil cooler to pass around the starboard side of the engine in a smooth curve to the connection on the oil pump inlet in the front of the engine. The hose from the starboard side of the Oil cooler should be routed to the OUT connection on the oil tank.
- e) Remove the cowling now and Install the hose from the sump connection beneath the engine passing beneath the lower cylinder head water pipes, but above the exhaust pipes, to connect with the inlet on the oil tank (the angled one towards the side of the tank, furthest from the filler cap).
- f) Check that the oil pipes do not come close to or contact any part of the exhaust, or anything else which may chafe or otherwise affect them.

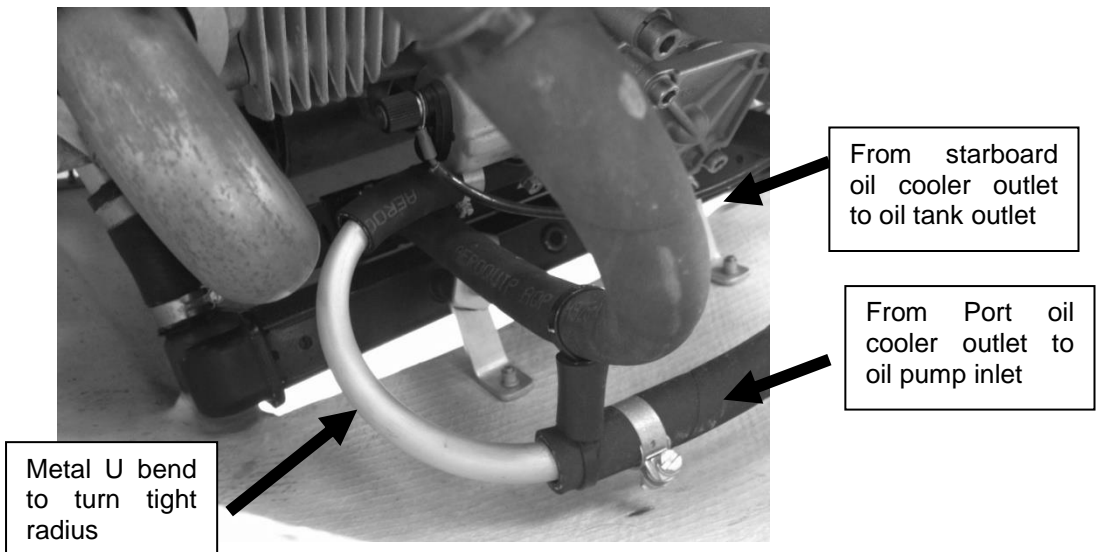
*Use cable ties to secure them to the engine / water pipes etc. when these have all been fitted.*



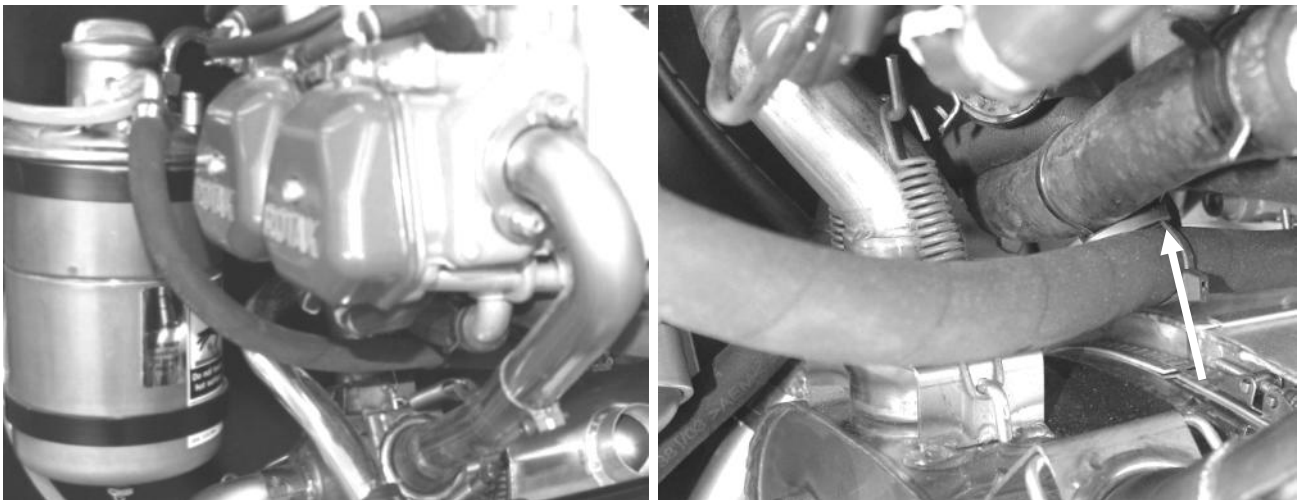
**Figure 205 routing of oil hose from oil cooler connection to outlet on oil tank. Note use of cableties through short lengths of fuel tubing to act as standoffs on fuel pump and inlet manifold to secure hose.**



**Figure 206** hose should be pulled forwards with cabletie and short standoff in position indicated to provide good clearance from fretting on engine



**Figure 207** Hose routings from oil cooler outlets



**Figure 208** Routing of oil hose from Sump connection to inlet of oil tank. It should be cabletied up to the small water pipes under the engine in the position marked to keep it clear of exhaust.

## 11.3 Water cooling

- a) Fit the starboard water pipe assembly . *This has straight hose at both ends. The rear connects to the water pump outlet on the back of the engine.*

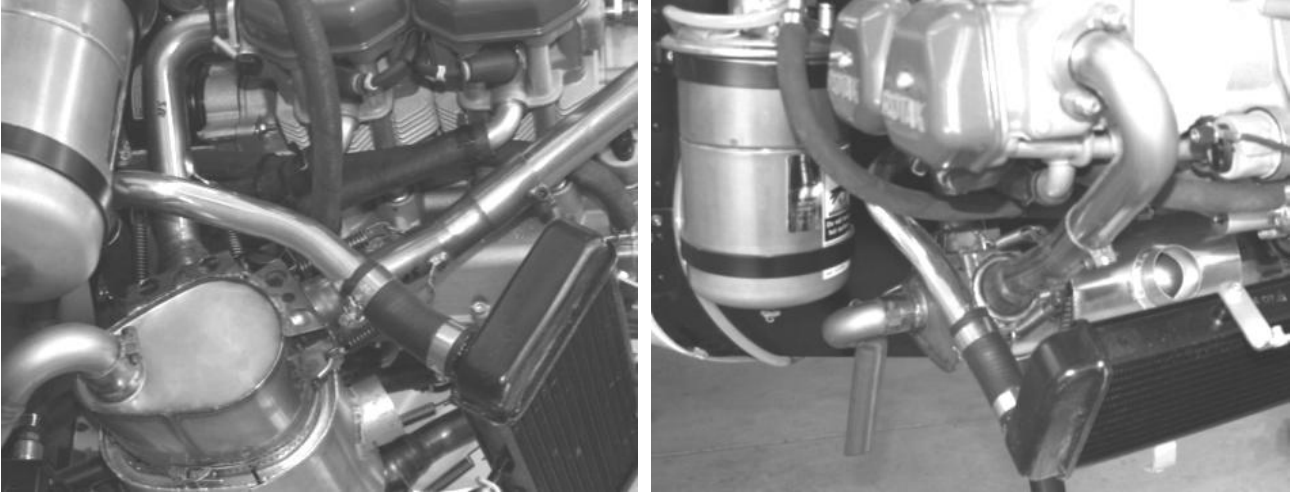


Figure 209 starboard water pipe.

- b) Remove the port-side carburettor inlet manifold.  
c) Remove the rubber water hoses between the expansion tank and the elbows on the port-side cylinder heads.  
d) Remove the elbows from the port-side cylinder heads and swap them over between the front and rear cylinder heads.

*This will change the outlet angles and allow the expansion tank to be rotated clockwise a little.*

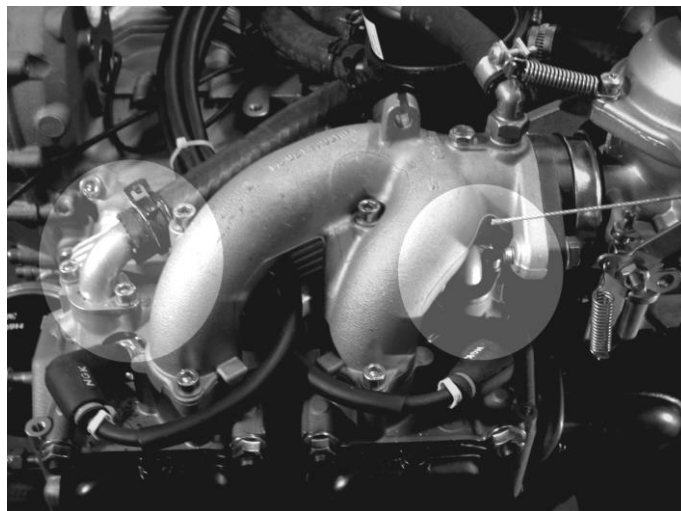


Figure 210 water pipe attachment elbows to left of, and under, inlet manifold.

- e) The water temperature gauge sender T piece should be installed in the front port water pipe on top of the engine, Fig 215



*The sensor for this is actually the CHT sensor from the front port cylinder head. Unscrew this and screw it into the water temperature fitting, using a touch of sealant on the threads. Note that the fitting is supplied as part of the instrument package option – not the main kit.*

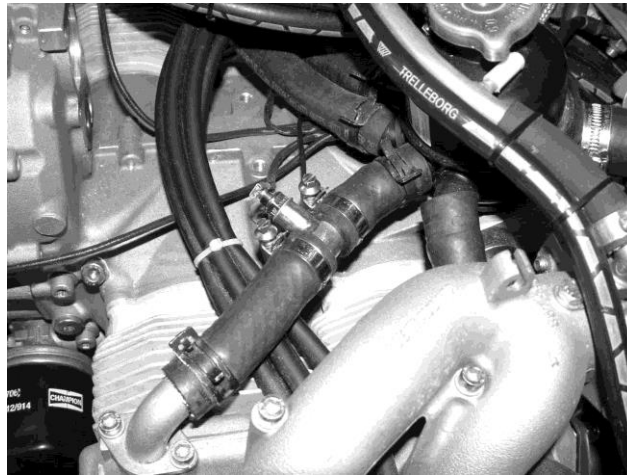


Figure 211 water temperature sensor.

***Note – cylinder heads on 912UL and ULS engines manufactured after early 2013 now have ‘wet’ CHT senders, and thus read coolant temp direct form the Cylinder head, and no additional coolant temp measuring is required – and the above is all non applicable. See rotax service bulletin SB-912-066***

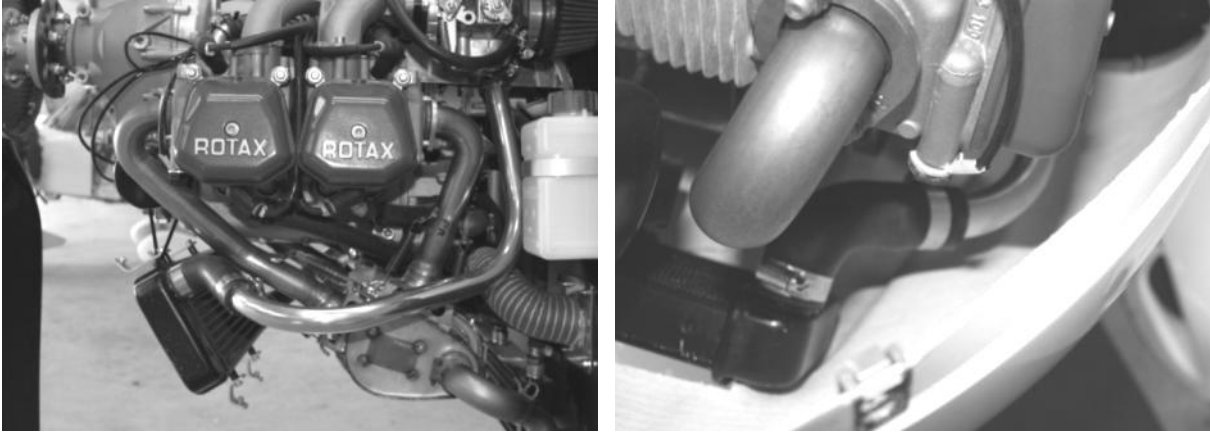
- f) Refit the hoses. *The hoses may have to be repositioned slightly to effect maximum rotation of the expansion tank.*
- g) Fit the rubber elbow on the port water pipe assembly to the expansion tank, passing between the carburettor and the upper engine mounting plate.  
*Trial fit the inlet manifold and carburettor to check the positioning of the rubber elbow. The elbow may touch the engine mounting plate. In this case position an additional piece of rubber hosing to prevent wear.*
- h) When satisfied with the positioning, refit the manifold using a torque setting of 10Nm (1kgm, 7ftlb) on the 6mm diameter bolts.
- i) The intake manifold balancing tube, crossing the engine in front of the carburettors, must be curved forward more than its standard position to allow more room for the expansion tank in its new position.



Figure 212 expansion tank and rubber elbow.

- j) Fit the elbow at the front of the port water pipe assembly to the radiator.

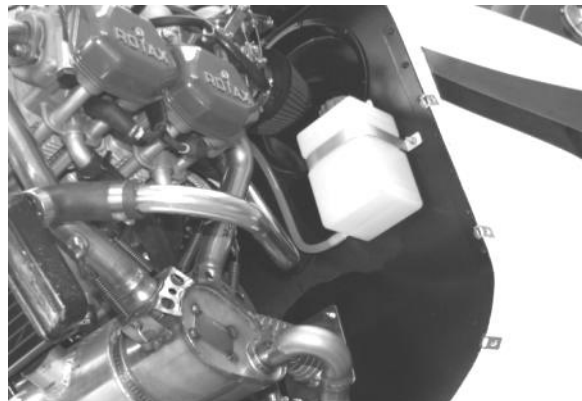
*It should be trimmed on the part closest to the water radiator to get the curve forwards as much as possible to give maximum clearance from the exhaust. Make sure it is pushed home fully. Note all elbows are supplied over long and should be trimmed for best fit. Before tightening the jubilee clips rotate the elbows and piping to ensure best fit/maximum clearance.*



**Figure 213 port water hose.**

- k) The water overflow tank should be mounted on the port side of the firewall by bending the securing strap around the indent in the tank and securing it to the firewall with two 4mm screws. Use a square of self adhesive hook and loop Velcro between overflow bottle and firewall. This will ensure no fretting.

An optional different style of overflow bottle may be supplied with integral bracket. Note that either type should have an overflow pipe through the cap. This should be routed down the side of the tank with its end expelling downwards.



**Figure 214 overflow tank.**

- l) Finally, check the tightness of all the jubilee clips.

## 12 Fuel System

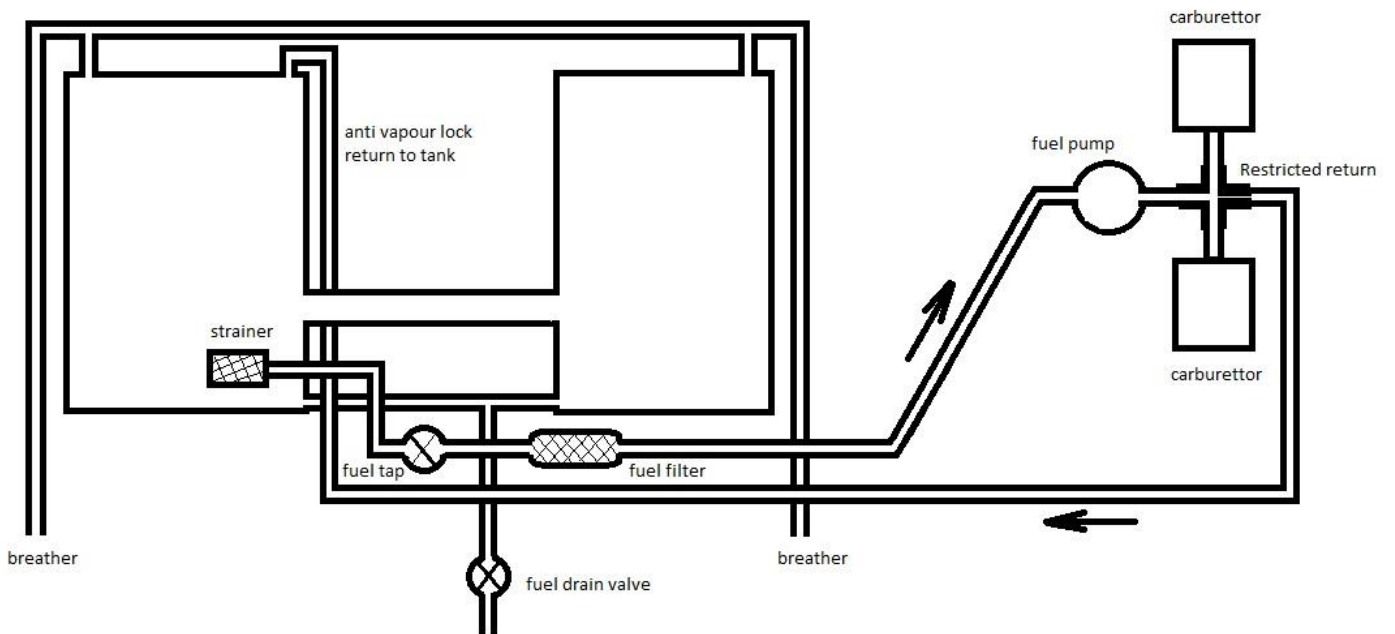


Figure 215 fuel system schematic, Rotax 912.

### 12.1 Fuel lines and connections

The kit is supplied with Black rubber based flexible fuel line. This should be used for all fuel connections and lines which are 'wet' with fuel in use. See through Tygon type hose is also supplied. This should be used only for the breather system.

'Miniclip' type screw up hose clips, and crimp type hose clips are supplied in the kit. The crimp type crimps are less bulky and have no sharp edges. Use these on connections that will not have to be undone for routine maintenance tasks. For those connections use the mini clip screw type hose clips - examples – both sides of fuel filter, Connections to fuel pump, final connections to carburettors.

The crimp type connectors are crimped using a simple pair of pincher pliers:

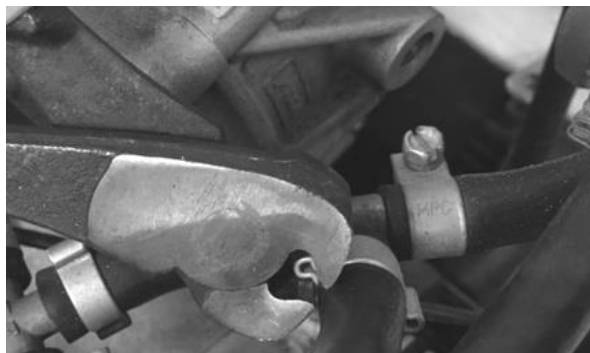


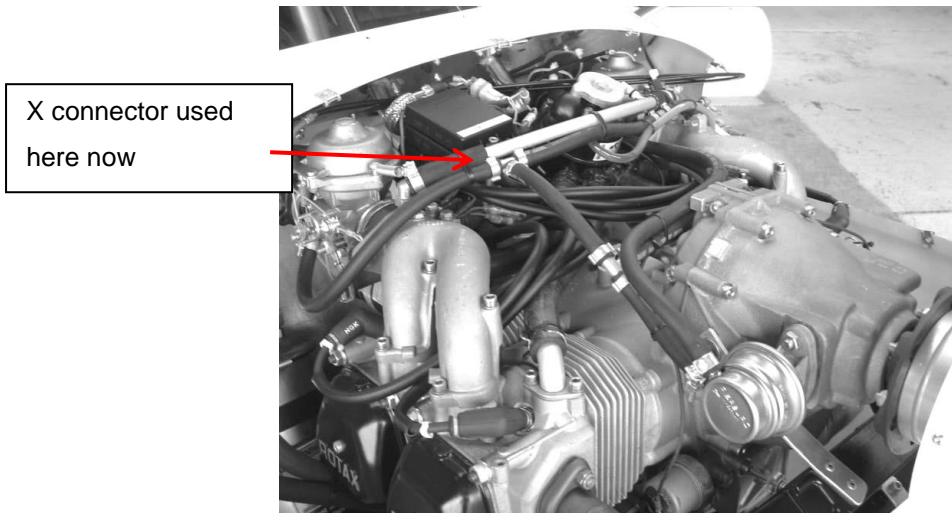
Figure 216 crimp connectors

## 12.2 Engine compartment

- a) Fit fuel lines from carburettors to a X connector

*Remember to slip the appropriate pipe clips over the pipes.*

*The fuel pipe joining the two carburettors can be conveniently clipped to the intake manifold balance pipe.*



**Figure 217 fuel pipe routing in engine compartment.**

- b) The X connector has one outlet with a restrictor. This should be positioned to face rearwards and should be connected to the anti vapour lock return line to the fuel tank..
- c) The front of the X connector connects to the fuel pump outlet (the smaller diameter pipe spigot on the pump).
- d) The fuel supply pipe from the tank connects to the inlet of the fuel pump (the larger diameter pipe spigot on the pump).

*Note that although the fuel pump inlet and outlet tubes are of different diameters, the fuel tube will fit over both of them.*

*A useful tip: to fit 1/4" bore flexible rubber pipe to 8mm metal tubes tenderise (as per a steak) the end of the rubber pipe, or heat it by dipping into boiling water. This softens the end. Then with a small drop of light oil (3-in-1) placed on the tube or the pipe, slip the rubber tube over the metal pipe. A slightly larger pipe clip (no13,14 or 15 depending on fuel line wall thickness) should be used.*

*The fuel supply pipe and the fuel return pipe both pass behind the gearbox and back over middle of the engine and under the centre piece of the engine mount, to pass through the firewall beside the rear of the starboard upper engine mount. Make sure the holes in the firewall are edged or grommeted to prevent the fuel lines from Chafing.*

- e) Once through the Firewall the rubber fuel hose is connected to aluminium fuel pipe. This runs along the underneath of the starboard TU19 tube down towards the fuel tanks.

. Secure the aluminium fuel pipe to the TU19 using cable ties spaced every 150mm or so. It is soft pipe designed for bending so it can be contoured where necessary simply by hand. To prevent chafing cut some short (20mm) lengths of the Tygon fuel tubing (the transparent yellow or blue stuff) split them along their length and clip them over the aluminium fuel pipe at the positions to cable tie, to stand it off slightly.

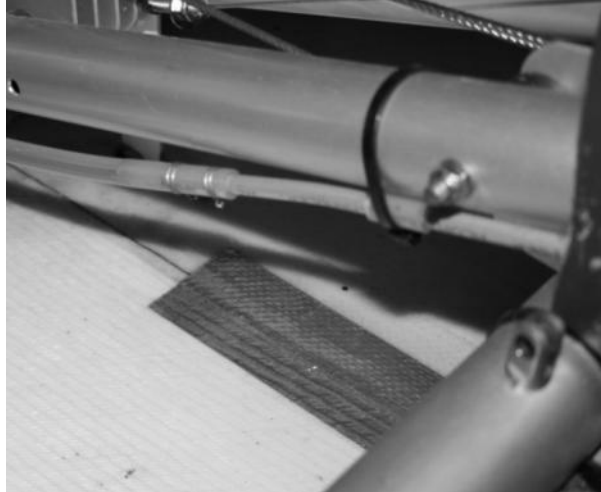


Figure 218 aluminium fuel line, cable tie and standoff.

### 12.3 Fuel Tanks



Figure 219 tanks overview

- a) Your (UK) Nynja fuel tanks are supplied pre drilled for the fittings, and the outlet strainer fitting should be ready fitted.. Check the holes in the tanks have smooth sides without flashings. If necessary lightly sand with fine wet and dry sandpaper.
- b) Identify left and right tanks. The right (starboard) tank has the filler neck fitting fitted through the screw on cap.
- c) Fit the rubber part of the push in fittings in all the holes. Plastic right angle elbows are use in the top outer most holes in the tanks for the breather connections. Metal elbows should be used for all the other fittings.

*Push the rubber part in first and then the insert. Use some lubrication (light oil, a touch of grease or some liquid soap) to help it slide inside.*

## **12.4 Fitting instructions for HADS Optional Mod 33 – Large diameter balance pipe between fuel tanks**

### **Overview**

This optional modification allows for fast balancing between fuel tanks during filling. Since early 2015 this has been included with Nynja kits

### **Parts:**

The kits should include the following:

<b>Part</b>	<b>No. off</b>
Tank fitting	2
Viton washer	2
25mm id fuel hose	170mm
Hose clips a2	2
Fitting guide wire	1

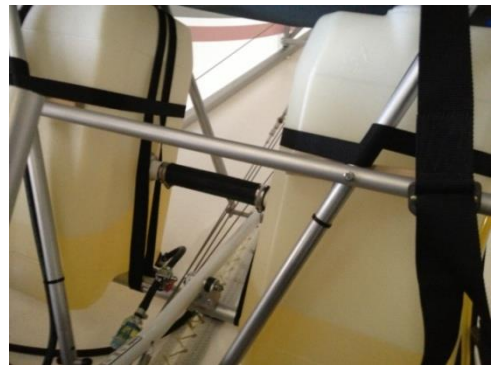


Fig 220



Fig 221

## Fitting

Incorporation of this modification should be carried out on tanks prior to fitting.

Mark the tanks for making the holes for the tank fittings. Make sure you mark the tanks on the correct faces – the inner ones as shown in fig 220. Mark up 100mm from the lower ridge in the side of the tank and central laterally as shown in fig 222.



Fig 222

This is the centre for a 33mm diameter hole that must be cut in the tank. We suggest using a cone cutter. Maplins usually stock them up to 32mm – we used that with a wiggle to finally open to 33mm – Fig 223.



Fig 223

Any flashings should be dressed out with abrasive paper so hole edges are nice and smooth – Fig 224. Then remove all debris from inside the tank.

Use the fitting guide wire supplied in the kit. Straighten it out and thread it through the filler cap and out of the hole you have just made. Thread the wire through the tank fitting and bend the end over – Fig 224. Pull the tank fitting through the cap and out of the side hole - Fig 225.



Fig 224



Fig 225

Screw on the big nut and tighten firmly. A pipe wrench can be used to do this as shown in Fig 226. We used some cloth to stop the jaws marking the nut. Hold the fitting firmly whilst tightening to stop it turning with the nut.

Tanks can then be refitted. Leave the fixing straps a little loose so tanks can be moved around to fit the fuel hose



Fig 226

between the fittings. Fit it and slide it on as far as it can go on each fitting and tighten the hose clips. Finally, position the tanks so the fittings aren't being pushed in or outwards, then tighten the tank securing straps. Refer to Fig 226.

### **12.5 Fuel tank load spreader bars**

Ensure that these were fitted earlier, in the section on the forward fuselage. Ensure long edge faces outwards..

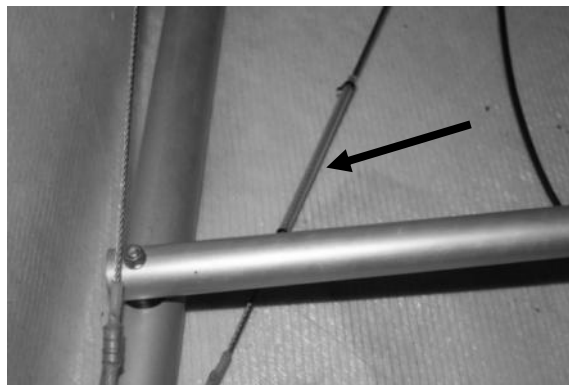


**Figure 227 fuel tank spreader bar.**

### **12.6 Fuel tank securing straps**

- a) Apply some protection on the lower bracing cables just behind the crossbar that the tanks fit on (the one that the flap handle attaches to), to protect the rear corner of the tanks from abrasion.

*Use a piece of fuel tubing or similar split and slipped on then held in position with cable ties. As shown below.*



**Figure 228 protection on lower bracing cable.**

- b) Push fit the tanks onto the cross bar in the rear fuselage, with the filler cap of port tank forwards, and filler inlet facing rearwards on starboard tank.

*You may find it easier to fit the pipework to the tank fittings with the fuel tanks sitting loosely in place, before strapping them down. See the next section for the details of the pipework.*

- c) Fit the tank securing straps, There are one long and one shorter one for each tank. The long one goes over the top of the tank, down the other side and



passes under the support bar before looping back up over the tank again, down and around the support bar on the other side. It looks neatest with the buckle on the outer side of the tank.

- d) The short one passes around the back of the tank and at the front should loop around the TU27 diagonal tube. Again the buckle is best on the outer side.
- e) Pull everything tight, working the tension around the system until even.
- f) Finally tie off any loose strap.

## 12.7 Fuel tank connections

- a) The fuel drain should be connected to the fuel balance pipe (the lowest if two are fitted). Fit the pipe with a T-piece to connect the fuel drain, which must discharge clear of the aircraft, Figure 229

*The fuel drain tap is fitted through the fuselage fairing just behind the port undercarriage leg. Fit from below with a nylon washer either side of the fairing. Fitting the fuel pipe pushed down firmly clamps the fitting in position.*

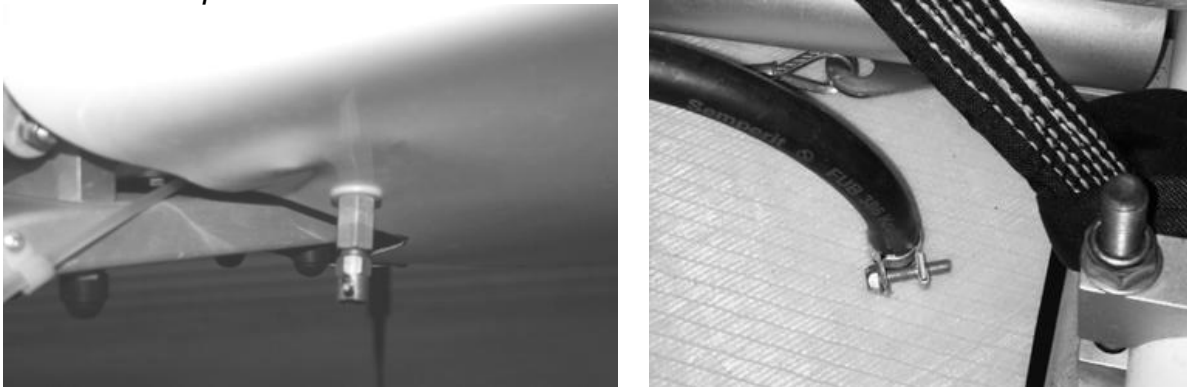


Figure 229 fuel drain.

- b) The fuel supply pipe should be connected from the strainer fitting to the fuel tap. The fuel tap should be mounted between the fuel tanks towards the starboard side, Figure 230.

*The mount for the fuel tap is a small piece of aluminium angle, attached with a 4mm steel rivet onto the cross-tube below it.*



Figure 230 fuel tap, filter and connections

- c) The tap should then be connected to the fuel filter, and then run forwards to connect to the aluminium pipe. *(Note that the filter will have an orientation marker in the form of a flow direction arrow)*
- d) The fuel return pipe from the engine compartment should be attached to its fitting in the top of the starboard tank.
- e) Both breather fittings should face rearwards and have short lengths of tubing attached to T connectors. The breathers then connect together across the top of the tank with a length of 8mm aluminium tubing, cut this to 620mm
- f) Flexible tubing should then be run down the outside of the fuel tanks to pass through the floor. Use the barbed aluminium fittings for this.

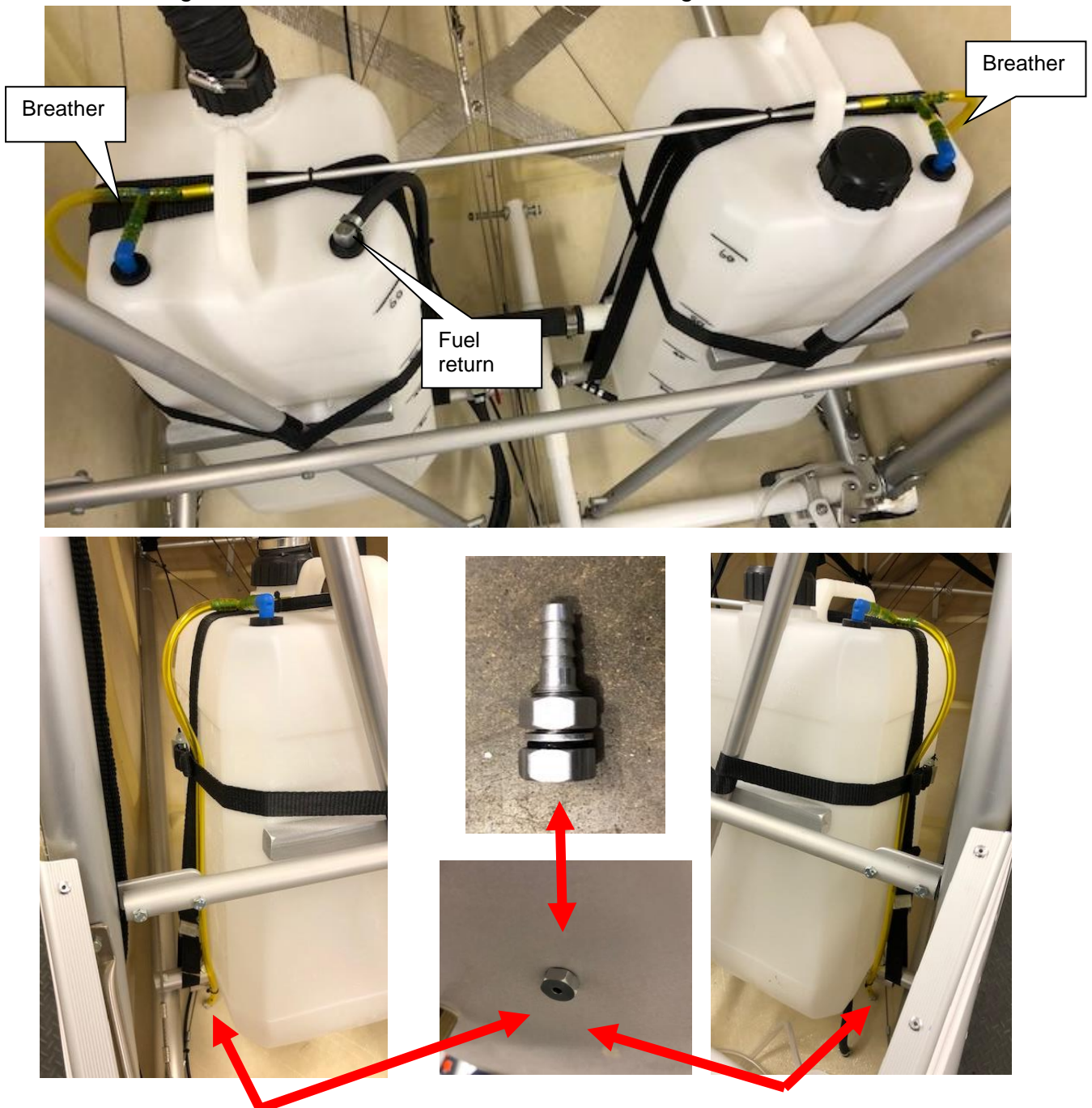


Figure 231 fuel tank breathers

## 12.8 Fuel filler

- a) Cut a 85mm diameter hole in the fuselage fairing to accept the fuel filler fitting in the position shown below:

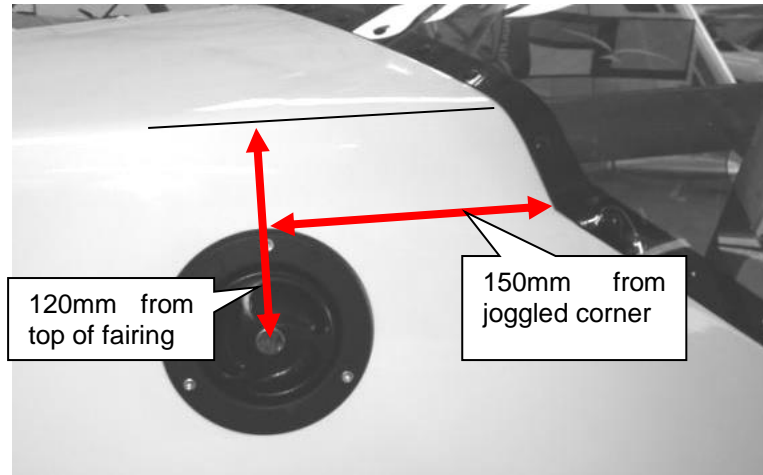


Figure 232 filler location

- b) Offer up the filler hose and find the best angle for the filler to be positioned
- c) The fitting can now be secured to the fuselage – by drilling and using 4mm nuts and bolts.
- d) The flexible hose can now be cut to size and fitted – secured with two ‘jubilee’ clips.
- e) Finally fit a cap on the breather tube on the filler fitting. Use a 6mm plastic nutcap and epoxy or hot glue.



Figure 233 Tank filler hose

## 13 Instrument panel



Figure 234 instrument panel overview

a) Find the instrument panel angles and dashboard supports – shown below:

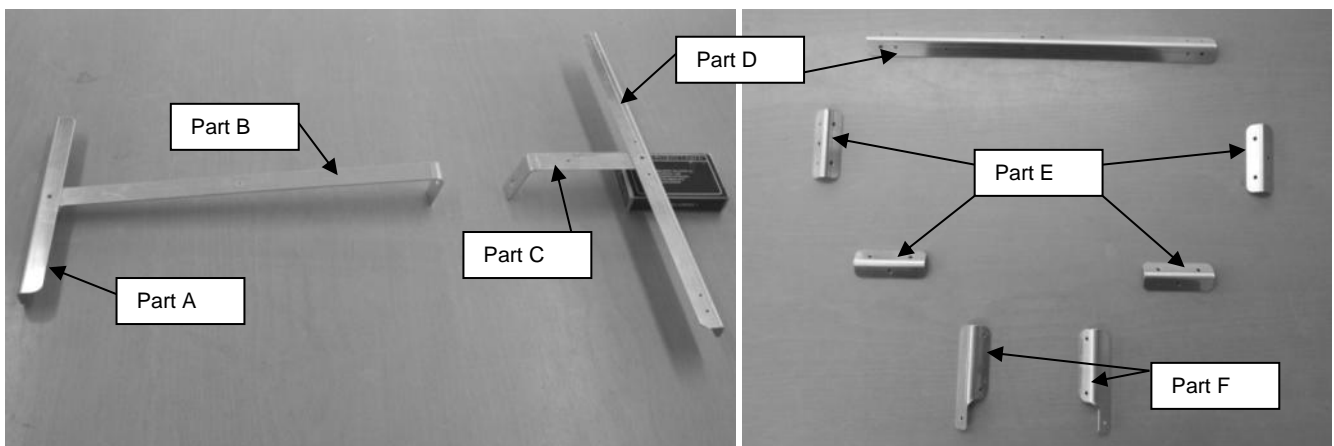
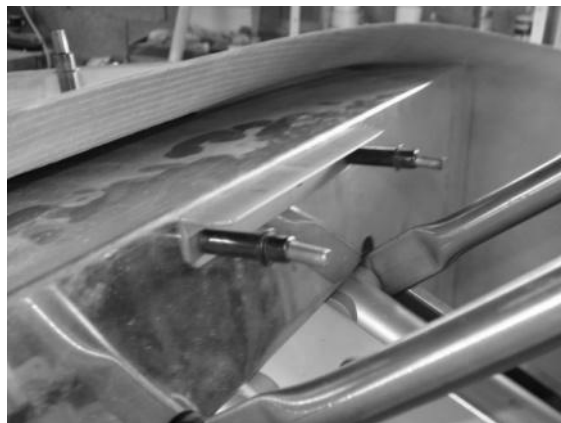


Figure 235 dashboard supports and instrument panel framing angles

b) Start with fixing the angle (part A) to the firewall flush with its top and centrally positioned, as shown below. Use 2x 4mm aluminium rivets.

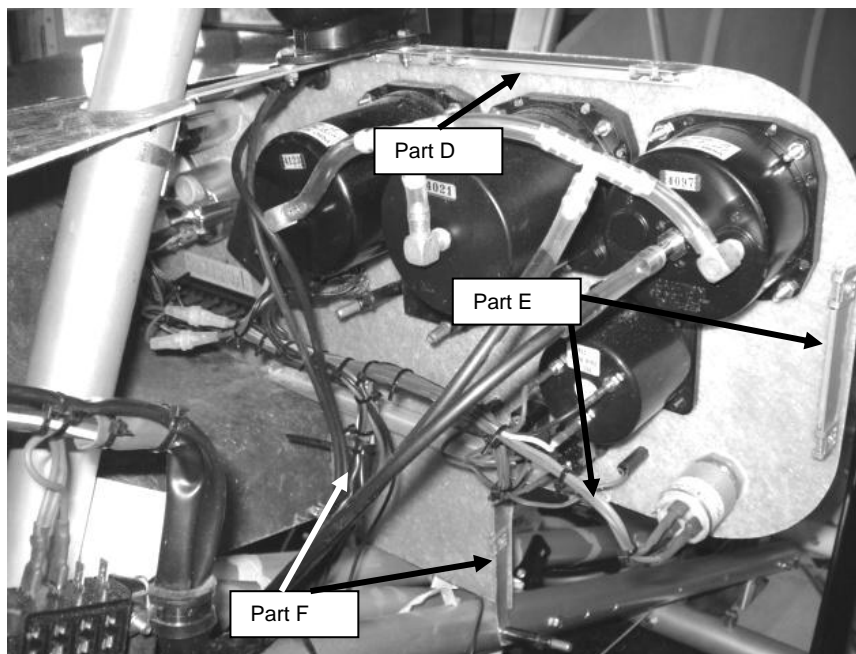


**Figure 236 mounting angle A**

- c) Part B attaches to underside of A with a 4mm nut and bolt. It attaches to Tube 14 at its rear. Part C fits from Tube14 to the top of the instrument panel. Attach then to Tube 14 with a jubilee clip and adjust position for alignment. Fit these to Tube14 now and make sure the holes align between A and B. Adjust with packing between B and TU14 if required. Note there is a hole in SKR14 and parts B and C which can be used to bolt all together – however using a jubilee clip allows adjustment for variations in instrument panel mounting – with the aim of B and C achieving a straight flat line from the top of the panel to part A

- d) Fit the angles D and E to the instrument panel edges. Use black 4mm rivets.

*Clipnuts slide over these angles to secure the dash binnacle mouldings slide these over now, and position the angles so that allowing for the thickness of the clipnut the edge is flush with the edge of the instrument panel, so everything will do up later nice and snug with no gaps or distortion. A nice alternative it to fit 4mm rivnuts in place of the clipnuts.*



**Figure 237 back of instrument panel showing instrument panel angles**

- e) Fit F angles and attach the instrument panel.

*Fit the F angle to the instrument panel. Standard 'low' position is with angles fitted so bottom edge of panel sits 5mm above the aileron torque tube. It may be lifted higher –up to around 30mm, but this will need some adjustment and packing of the A and B supports, and a check that centre console will match up with no gaps.*

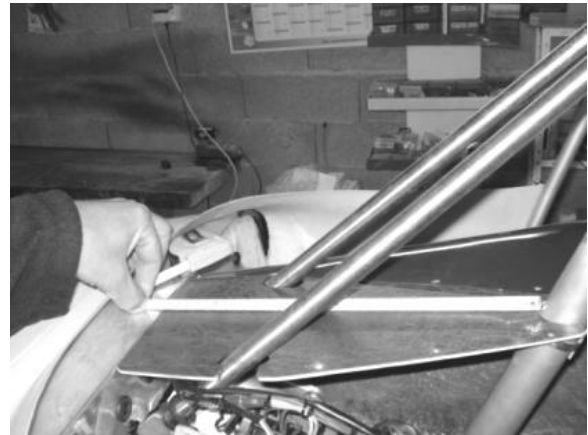
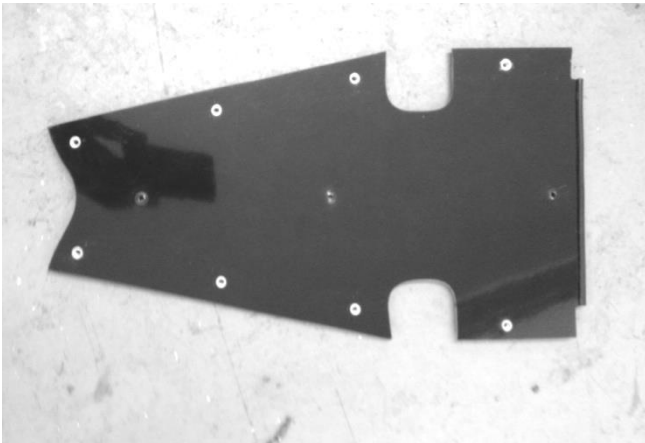
*The panel attaches at the bottom using 6mm bolts through the F angles and the foremost holes in the SKR19 tubes. At the top fix to the part C with a 4mm bolt. Standard Part C results in the instrument panel leaning forwards at the top. We lengthened the part C on ours to make the panel fit a little more upright. This also gives additional clearance for long instruments from the*

throttle arm and tube 14. We extended by around 20mm. Offer up the binnacle mouldings to see the limit of this adjustment.



**Figure 238 Instrument panel lower fixing, and instrument panel upper fixing (note - pics are of a Swift2 so firewall detail different)**

- f) Trim as required and fit the triangular dash top panel as shown below. Fix it at the front using the 4mm bolt and nut through A and B, and again with a 4mm nut and bolt mid point of B.



**Figure 239 triangular dash top panel**

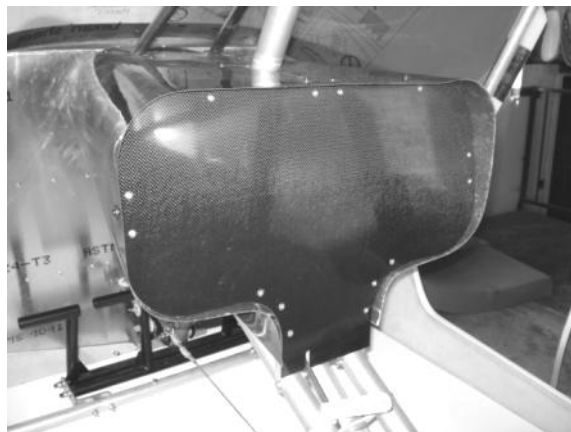
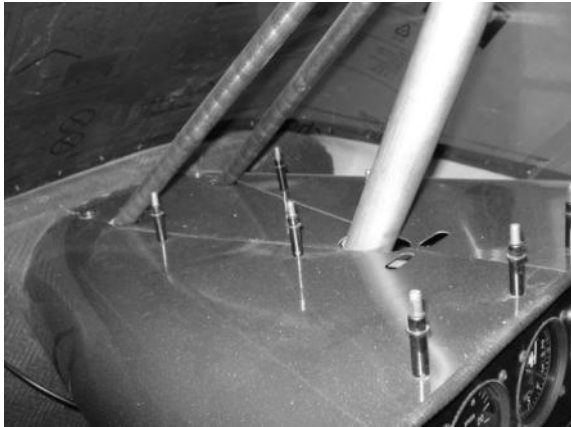
- g) Offer up the dash binnacle mouldings.

*Trim to fit snugly, but allow some room against the firewall for coverings. Cut the top to parallel the edges of the Triangular dash top as shown below. Overlap by around 25mm. It will also need cutting to allow for the dual throttle torque tube.*

- h) *When happy with the fit mark up and drill the securing holes. Use the 4mm clipnuts (or rivnuts) over the securing angles and the edges of the triangular*

dash top. Secure with the 4mm black flanged screws (or 4mm screws or plastic black panhead screws if using rivnuts).

The securing angles D and E may need bending slightly to match the exact angles of the binnacle sides and top so that it is not distorted when the screws are tightened



**Figures 240 dash binnacle mouldings**

- i) The binnacle mouldings overhang the instrument panel. Trim this 'to taste'. It is edged with a trim strip – leave enough for this!
- j) There are some markings for the aileron cable exit – we didn't use them exactly and cut as per photo below. Note that part C has been filed to allow for cable clearance at full aileron deflection



**Figure 241 Cable exit hole**

## 14 Throttle and choke

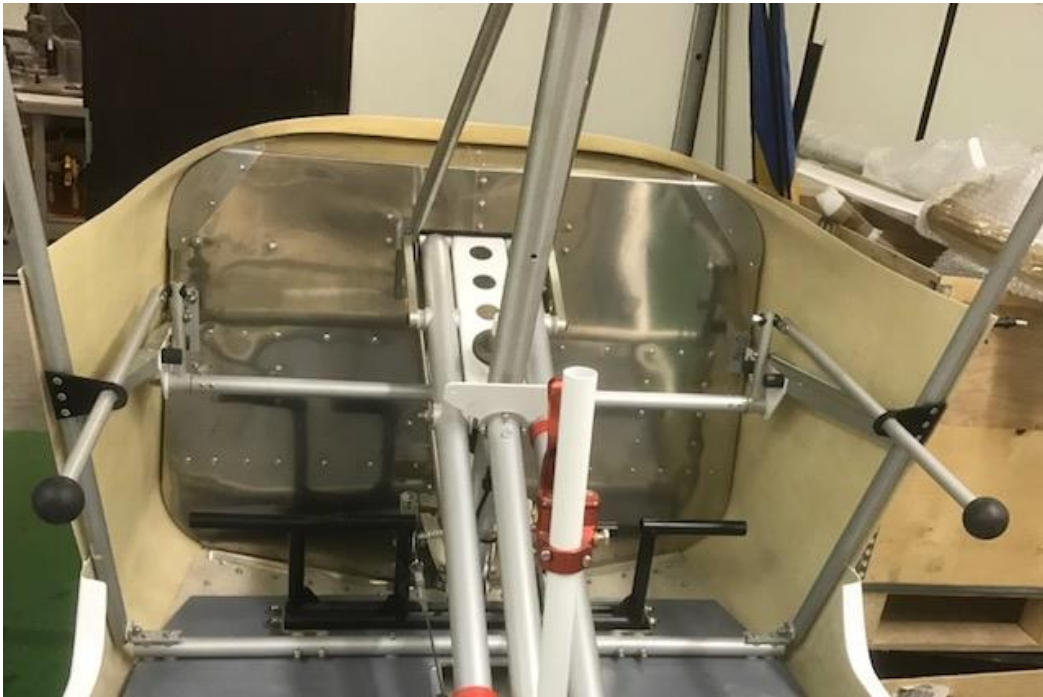


Fig 242 Overview of system

### 14.1 Fitting the firewall brackets

- a) Start with the left (port) bracket. This locates as shown on one of the pre drilled holes in the firewall used to fix the bracing angles on the other side of the firewall. Drill out the rivet if previously fitted, and hold the bracket in position with a Cleco / skinpin.

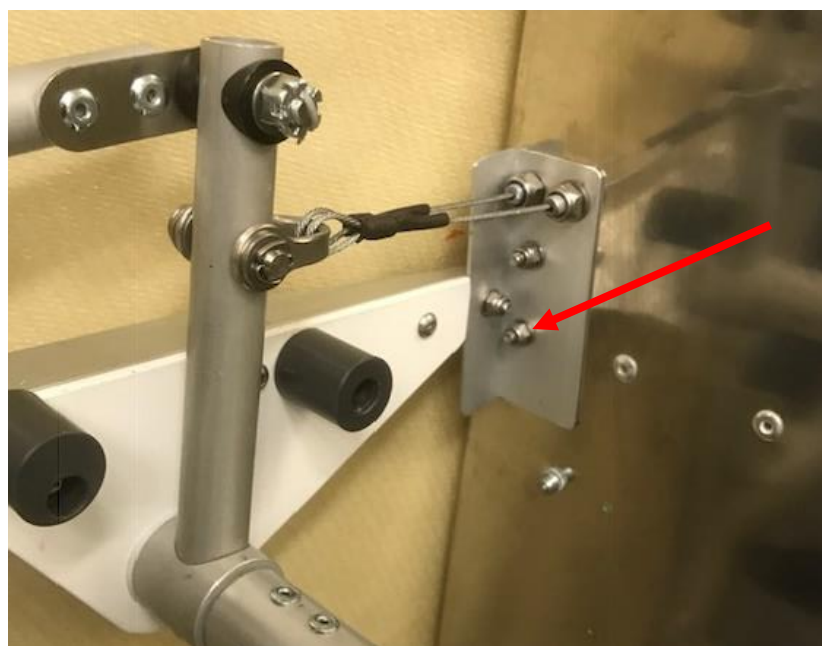
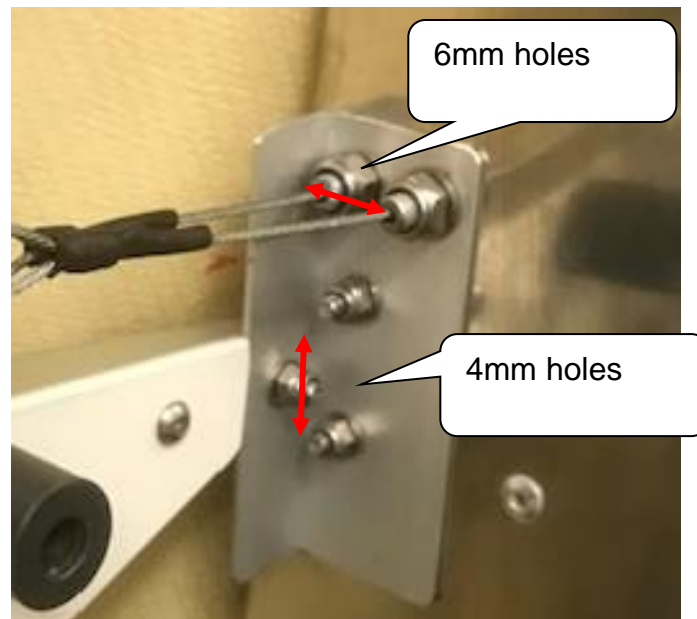


Fig 243



- b) Align the bracket so it is vertical and mark the position of the other three holes onto the firewall. Remove the bracket and drill the holes through the firewall. De burr the holes and attach the bracket using two 4-12mm screws and two M6 cable adjusters as shown



**Fig 244**

- c) Next fit the Right (starboard) firewall bracket. The lower hole fixes through the pre drilled hole in the firewall – as per the right hand bracket did. The bracket should be vertical and the upper hole drilled. Fix using two 4-12mm screws as shown.



**Fig 245**

## 14.2 Preparing the support angles.



Fig 246 Finished support angle pairs.

- a) Don't forget to make a pair! – below is shown the Left one of the pair. Angle is orientated horizontal edge on top. Drill a 5mm hole in the top 180mm from the front end, and cut into a V 10mm wide at the top using a hacksaw or dremel.

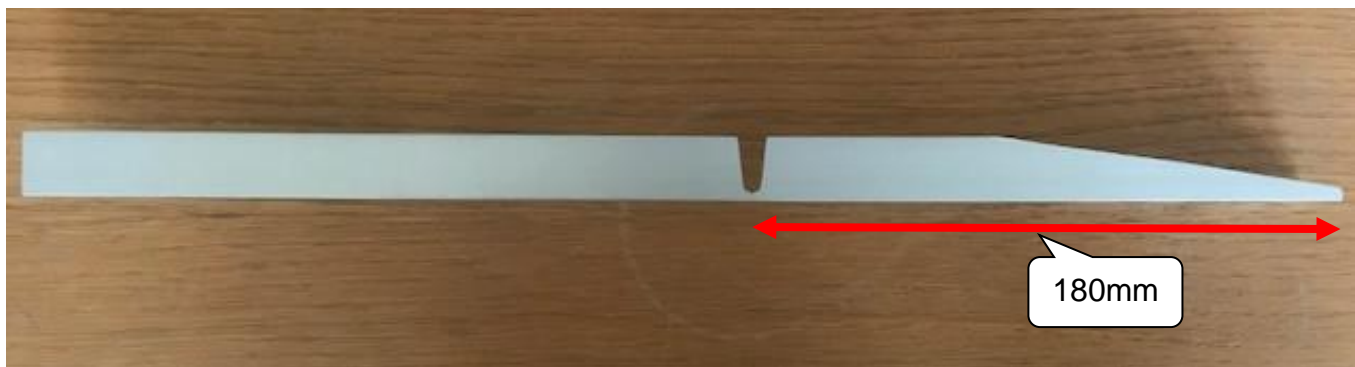


Fig 247

b) Cut a taper 100mm long in the top starting from the front end as shown below

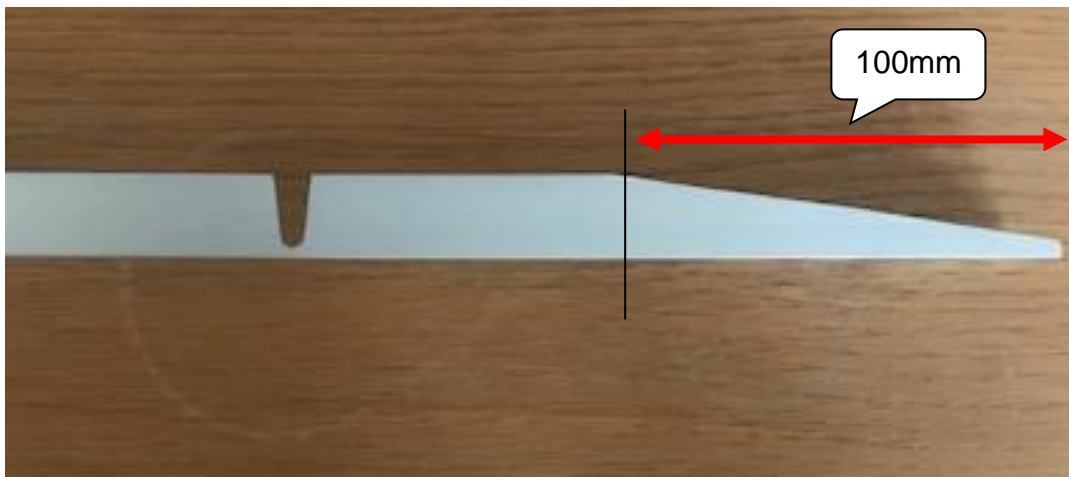


Fig 248

c) Next drill the vertical face of the angle with 4mm holes starting with the front 2 holes as below:

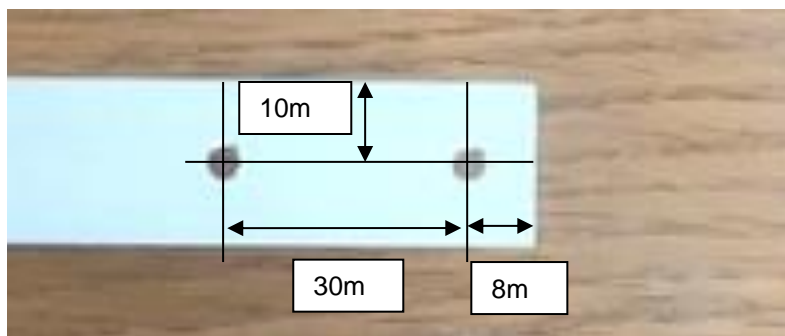


Fig 249

d) Offer up a throttle plate and cleco it into the second hole as shown below. Then using the holes in the throttle plate as a guide drill through them 4mm.

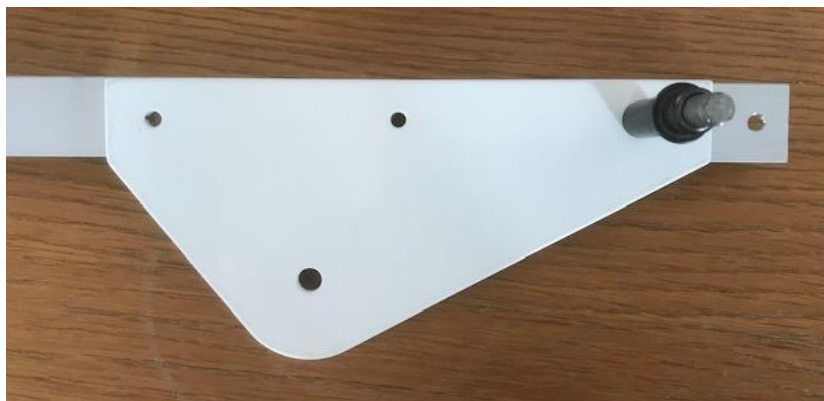
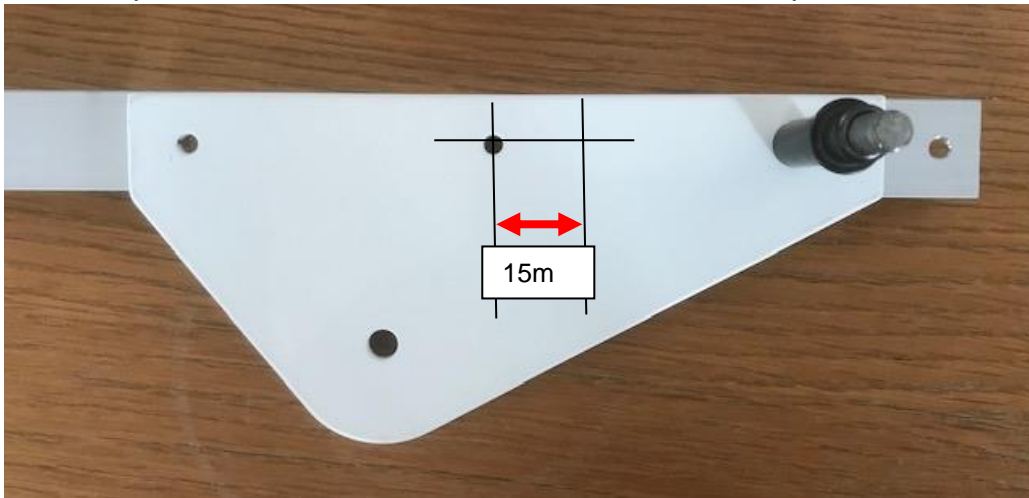


Fig 250

- e) Mark and drill another 4mm hole 15mm forward of the middle hole in the throttle plate. This hole is used for the front throttle stops



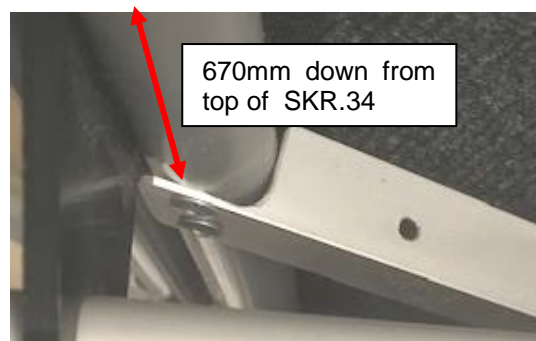
**Fig 251**

- f) Attach the throttle plate to the angle – with throttle stops as shown below (note rear stops are the accentric ones, and front stops the concentric ones), fixed with 4-25mm screws, and then use 4-12mm screws in the remaining two holes.



**Fig 252**

- g) Cleco the angle on to the firewall bracket. Bend the angle so that the throttle plate section is at right angles to the firewall.
- h) The rear of the angle attaches to the cabin upright tube SKR.34. The top of the angle should be 670mm from the top of the SKR.34 tube. Mark and cut the angle to fit around the tube in this position.



**Fig 253**

- i) When happy with the fit and positioning fit the plate to the top of the angle at the bend position



**Fig 254**

- j) Drill and fix this using 2 x 4-10mm aluminium rivets.
- k) Verify the fit at the rear and drill two 4mm holes to pass through SKR.34 tube centre. Fix with Clecos just now, use 4-10mm aluminum rivets for final fixing.



**Fig 255**

- l) Repeat the above to make a mirror assembly for the right hand attachment angle.

### 14.3 Throttle torque tube

Assemble the machined end parts SKR.737.



**Fig 256 Left side end assembly**

- a) Slide the throttle vertical arm inside the SKR.737. It needs to be a tight slop free fit. It will likely need a slight squeeze to oval the tube to achieve this. Do this in a vice and squeeze left and right sides. Only a very little should be needed! The vertical arm with three 6mm holes goes on the left side, the arm with a 4mm middle hole goes on the right side.



**Fig 257**

- b) An M6-50 caphead bolt is used as the axle. This should be an interference fit into the SKR.737. To achieve this squeeze the head to oval it. Apply loctite 270/ 638 (high strength retainer) and fit the bolt – driving it fully home into the SKR.737 with a punch and hammer.



Fig 258



- c) Repeat for the right side (note orientate so the 4mm hole should be above center).
- d) Fix the assembled SKR.737 ends onto the throttle plates. A WFL.1.6.24 plastic washer is used each side. Then on the outside a penny washer. The right side just has a single Nyloc nut only loosely applied. The left side is used to set throttle friction and has two nuts to lock together. But friction will be set later.



Fig 259

- e) With the assemblies in position on the throttle plates, measure carefully the distance between shoulders for the throttle torque tube SKR.743 to fit over them. Double (and triple!) check this measurement then cut the torque tube to length.



Fig 260

- f) Remove the SKR.737 assemblies and rivet the torque-tube to them using eight 3.2 x 10mm steel rivets per side.

**Do not drill within 12mm of the end of the tube. There should be two rings of four rivets each on each end,**

- g) Do one end first then verify both Throttle vertical arms are exactly aligned before doing the other end. When done fit the completed assembly between the throttle plates. With this done the rear edges of the support angles can now be riveted on to the SKR.34 cabin tubes and the 4mm screw at the front that connects to the firewall bracket can be finally tightened.

#### **14.4 Throttle levers**

- a) Rivet the connector tangs to the throttle lever tubes. Use 4-10mm steel rivets. First hole should be drilled so its centre is 7mm from tube end



**Fig 261**

- b) Attach to the assembly to the outside of the throttle vertical arm – arranged as below, loosely for now.



**Fig 262**



- c) Slide on the plastic guide. The centre hole of the guide should be 650mm below the top of the SKR.34 cabin upright tube. Try it in position and make sure the lever can slide back and forth without binding. If necessary open up the hole a little to achieve this – usually because of the relative angles it is the top outer and bottom inner edges of the hole that may need opening up.



**Fig 263**

- d) Throttle ball end knobs must be fixed to the tube to prevent them being pulled off when throttle is closed. They are fixed into position by drilling through the underneath and up through the tube using a 3.5mm drill. Then a 25mm mm self tapping screw is used to hold them. This is easiest done by removing the assembly to drill.



**Fig 264**

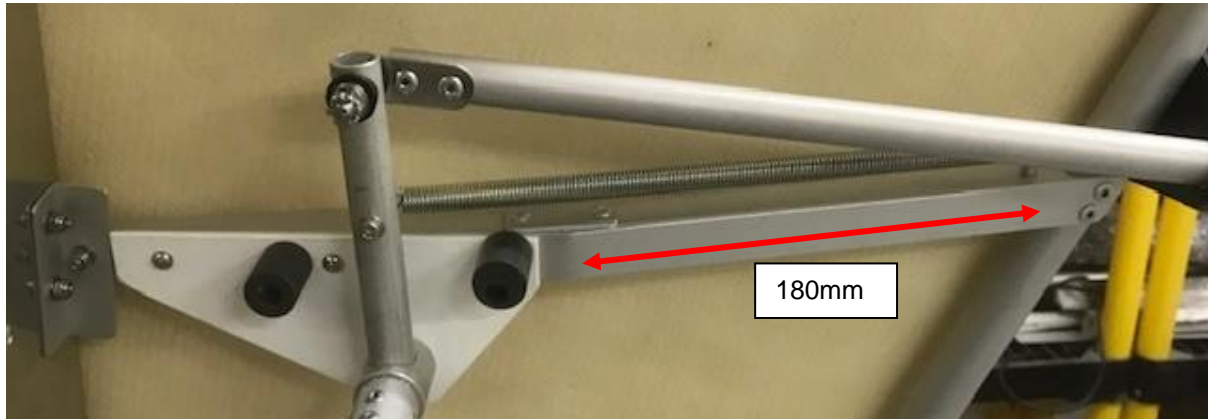
- e) Refit and then rivet the plastic guide in place on the SKR.34 uprights using the 4-10 aluminium rivets.



**Fig 265**

## 14.5 Balance spring, cables and friction.

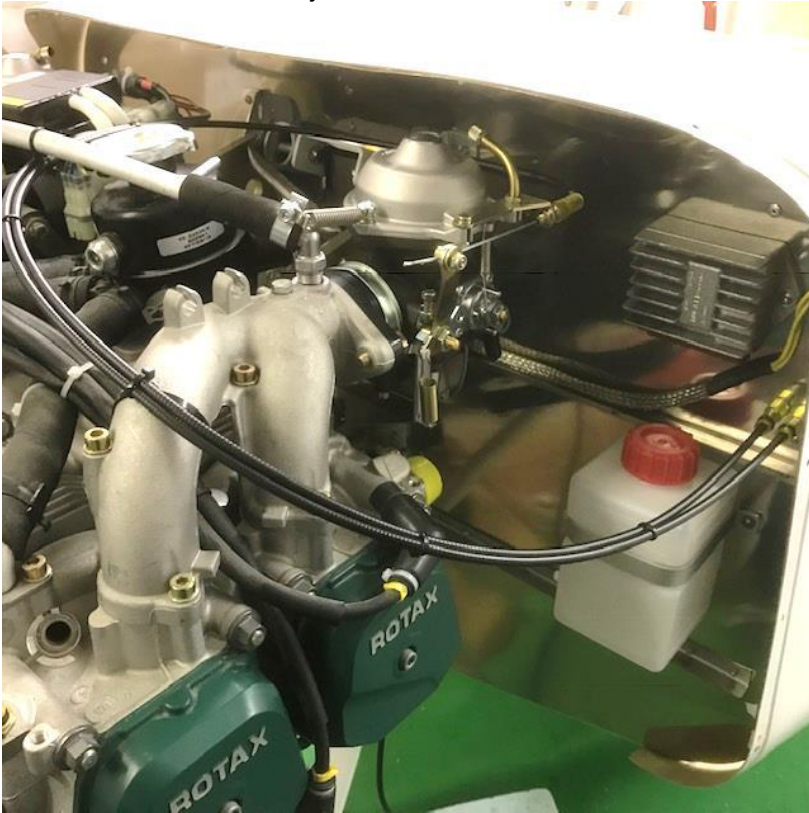
- a) A spring is fitted to the right side assembly to balance against the pull of the carburetor springs. Drill a 4mm hole in the middle of the top of the angle 180mm rear of the centre of the bend



**Figs 266**

- b) At the front the spring is fixed to the vertical arm with a 4-35 screw and 10mm long spacer tube. A washer goes under the screw head to stop the spring sliding off.
- c) At the rear the spring end is trapped between two washers so it can slide down, then attached to the top of the angle using a 4-20 screw and 10mm spacer tube.

- d) Throttle cables should be routed in smooth arcs, and supported so they don't rub or get caught on anything. See recommended routing below. Note also the short lengths of tubing on the cable ends to hold them in the cable adjusters in the firewall.



**Figs 267 throttle cable routings**

- e) Throttle cable inners attach to the left vertical arm as shown below. The U shackle should be free to move and follow the cable angle.



**Fig 268**

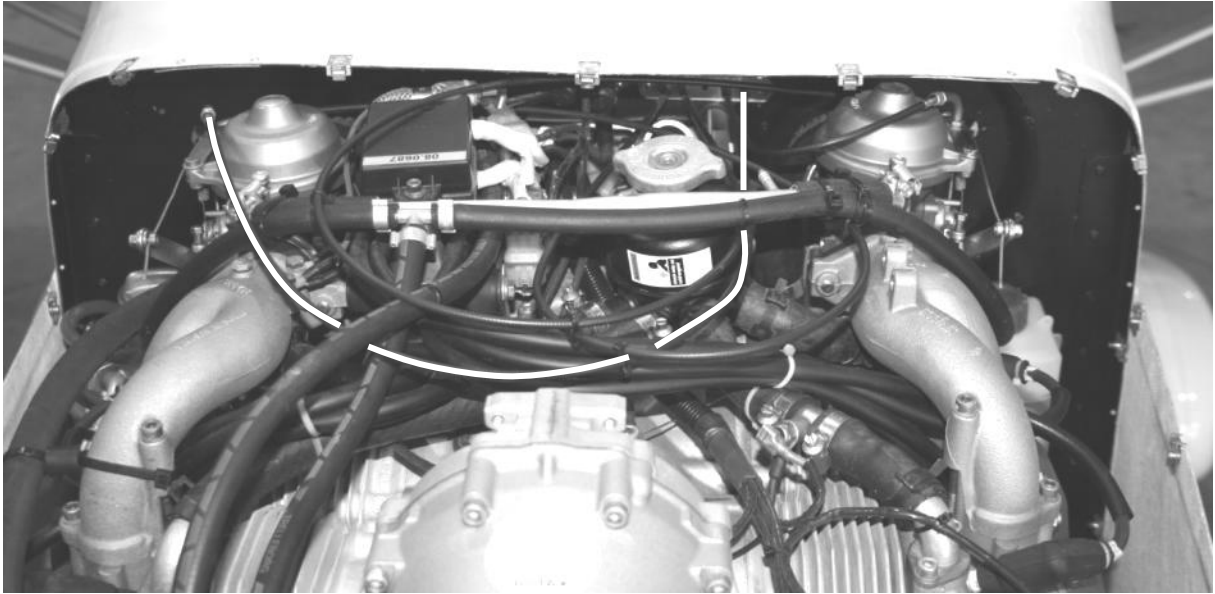
- f) The rear eccentric throttle stops should be set in the mid position and adjusted such that both vertical arms contact at the same time – or left arm very slightly before the right. Cable length should then be adjusted via the cable adjusters on the firewall and on the carburetors to synchronize carb openings and set the initial engine idle. The stops on the carburetors themselves should be set to be well clear of the levers on the carburetor so they have no influence. Subsequently the engine idle can be adjusted by means of the throttle stops in the cabin.
- g) Throttle friction should be set to prevent throttle creep, but not be over-tight such as to give a stiff and jerky throttle movement. To do this start by making sure the right side torque tube pivot assembly is not applying any friction – the nut should be tightened only to remove gaps / sloppiness.
- h) All friction adjustment should be done using the left pivot assembly. Tighten the inner one of the pair of nuts to set friction, then lock it from loosening by tightening the outer nut down on to it using two spanners – one to hold the inner nut still, and the other to tighten the outer nut down on it.



**Fig 269**

## 14.6 Choke cables

- a) Fit the choke cable bracket in position so the cables run as below



**Figure 270 choke cable route to starboard carburettor (in white)**



**Figure 271 route of choke cable to port carburettor (in white)**

- b) Possible interference with bonnet – the engine rocks quite a bit when starting. On some it has been found that the choke cable guide on the starboard carburettor in the position supplied from Rotax, can come in contact with the bonnet and cracks can develop. We recommend unscrewing and refitting cable to lie to the rear of the carburettor top.

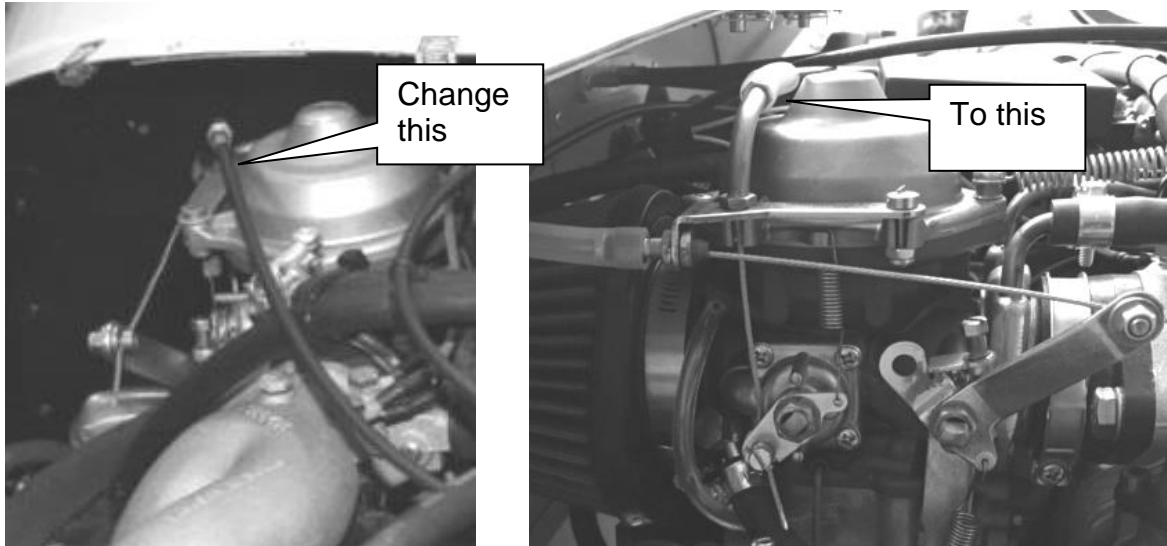


Fig 272

- c) The choke inner cable is a simple loop of cable covered with plastic tube where it passes through the instrument panel on the port side, Fig 279  
*A pop-rivet with the centre pushed out makes a neat cable guide for the choke cables passing through the instrument panel. Secure the rivets*

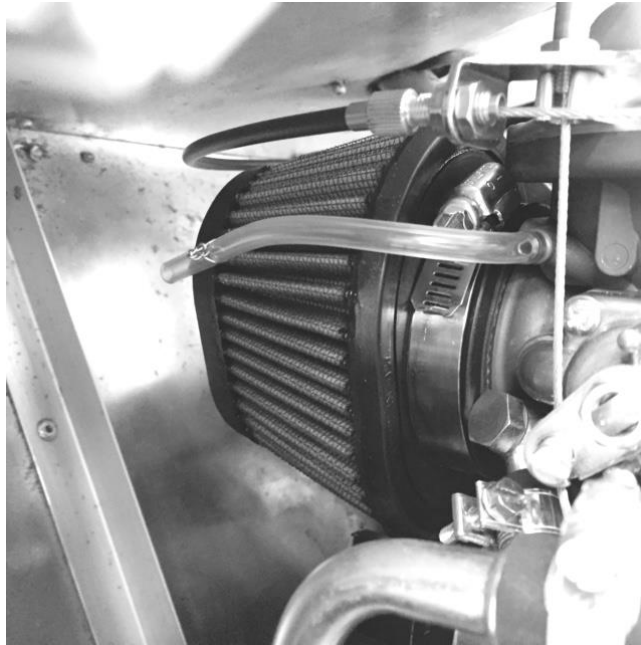
*with a small piece of tubing pushed over the rear of them, or with a touch of glue.*



Figure 273 choke.

- d) Air filters can be fitted now to the carburettors. The standard UK filter RU2780 requires a spacer ring to fit on the carb mouth. Make sure it is pushed fully forwards and clip done up tight so the filter is secure.
- e) The carburettor float chamber vent pipe should be lead backwards along a shallow decline and fixed with a small loop of lockwire to the rear of the filter. This will prevent any fuel overflow from landing directly on the exhaust.

*Don't be tempted to simply increase the length of this pipe to exit below the cowling – otherwise pressure differences can cause engine rough running and possible failure.*



**Figure 274 Fitted air filter and vent pipe**

## 15. Instruments

- k) Remove the panel and mount the instruments, magneto switches etc. in the panel as desired.

***However, note the position of the throttle cable lever arm and spring, and do not mount instruments so that they interfere with it. Be aware also that the binnacle sides taper inwards – which may give rise to interference with particularly long instruments if fitted close to the outer edges of the panel. We suggest making a mock up panel out of plywood before committing to cutting the real thing!***

*BMAA TILs 7 and 27 may be useful reading regarding the fitting of instruments.*

*A useful approach to cutting neat holes is to mark out the hole, drill a large number of holes inside this line close together, cut between them with a junior hacksaw, then finish the hole to the line with an abrasive flap-wheel in a power-drill. Sandpaper wrapped around a tapered wine bottle neck is also a good way to finally ease the holes to size – remember to leave plenty of time between consuming the contents and performing such delicate operations!*

*Sand along the edges of holes and not across them as this can lead to chips and fraying.*

*Edges of holes will have a whitish appearance. This can show if the gap around the instrument bezel is less than super tight. A good tip is to use a black 'sharpie' or equivalent permanent marker on the hole edges to darken them.*

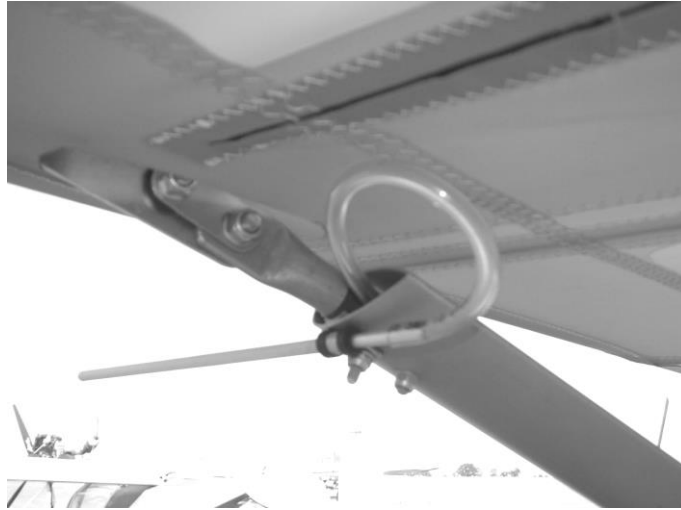
### 15.1 Pitot-Static System

This can be left until the final rigging stage, but is in the build manual here to group it with the instrument fitting section.

- a) The Pitot probe should be mounted at the port forward lift strut to wing attachment using a P-clip, fig 229

*Replace the standard bolt with a longer bolt (supplied with pitot tube).*





**Figure 275 Pitot probe location.**

- b) The connecting tube should be routed down the inside of the lift strut, to a push fit joiner tube at the fuselage to lift strut bolt.
- c) The fuselage piece of tube should enter the cockpit and pass under the floor and up behind the instrument panel to the ASI.

# 16 Electrical System

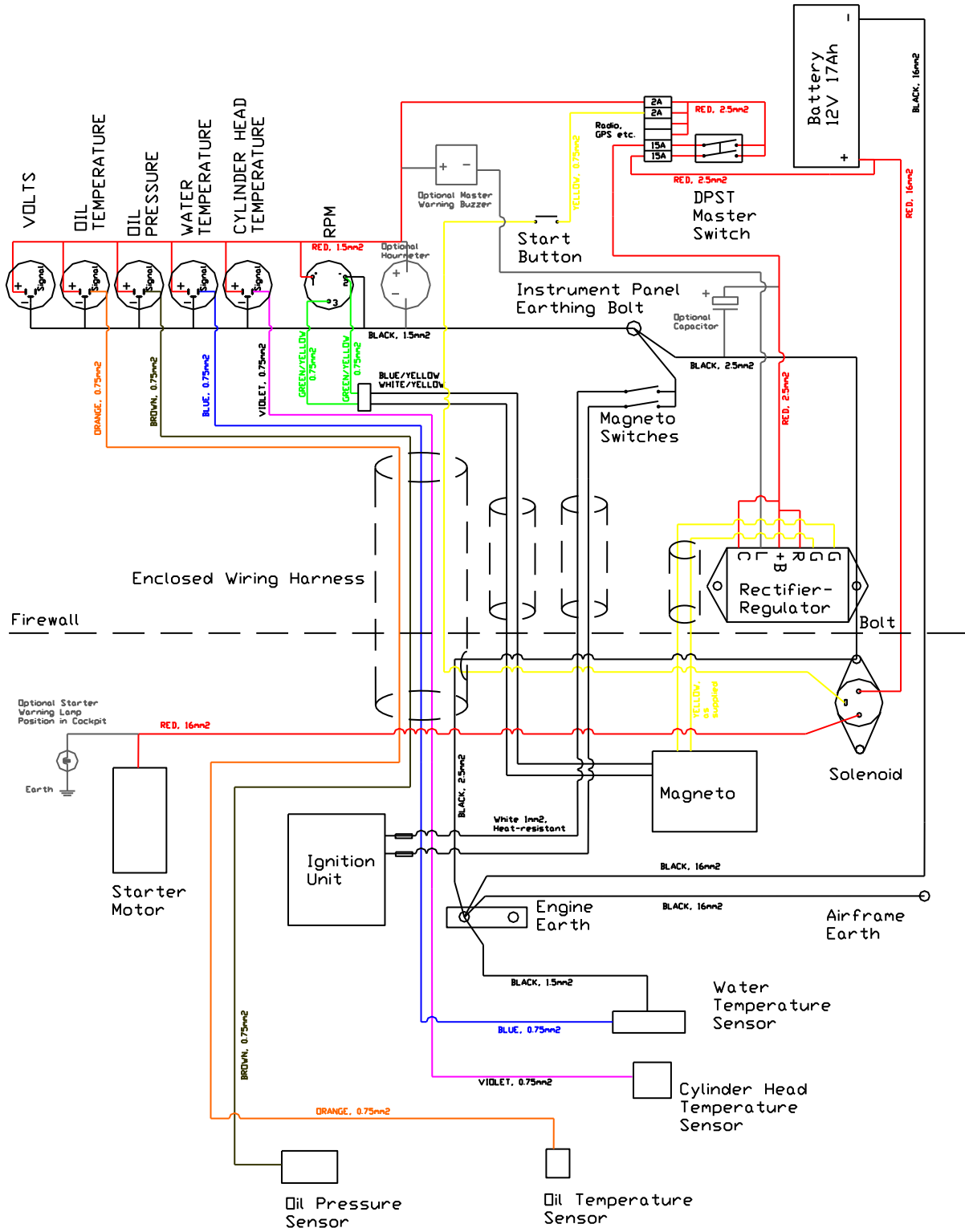


Figure 276 overall wiring schematic, Rotax 912 and standard analogue instruments.  
(ensure all colours are visible when printed out)

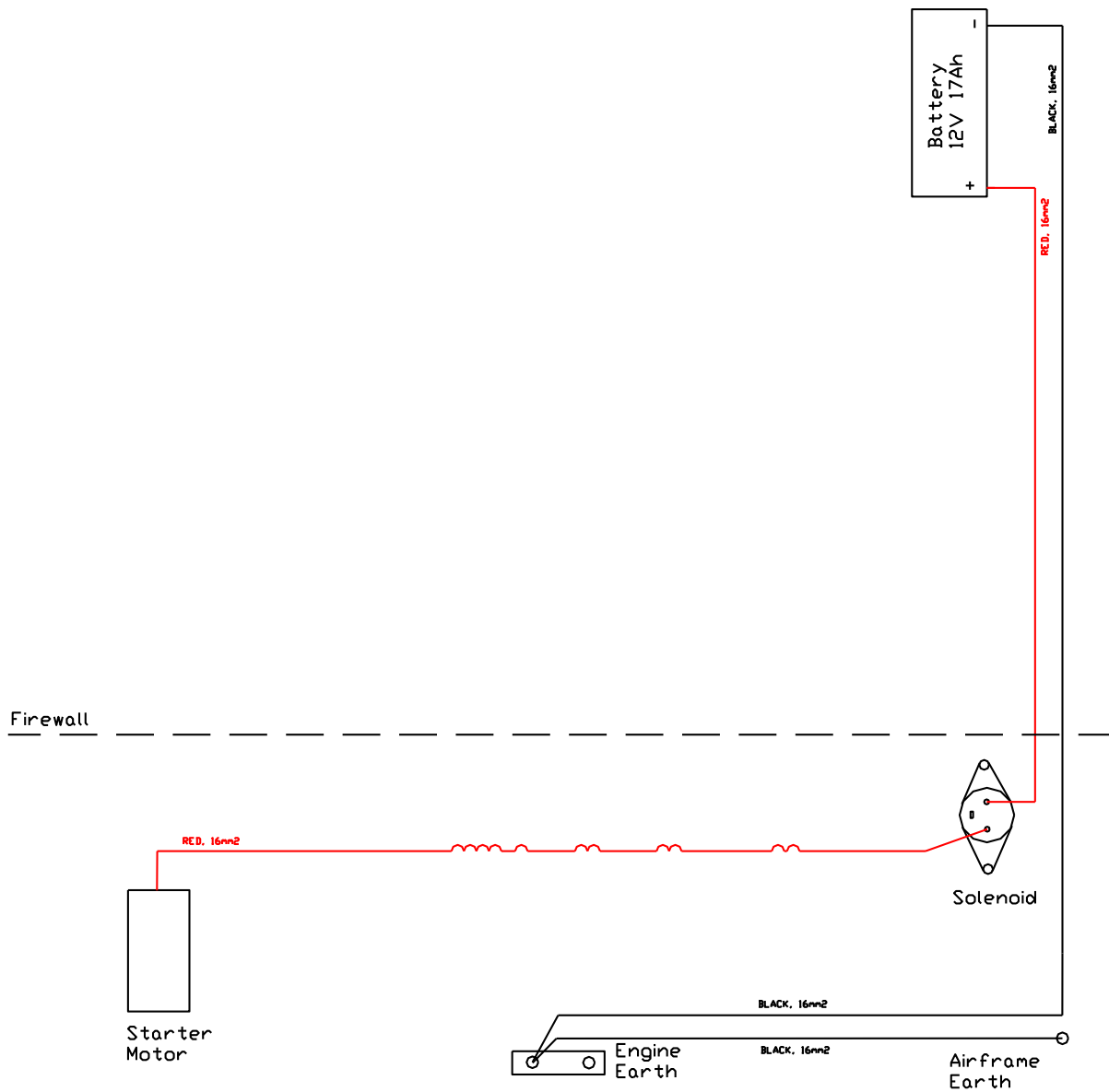


Figure 277 heavy duty power wiring schematic, Rotax 912.

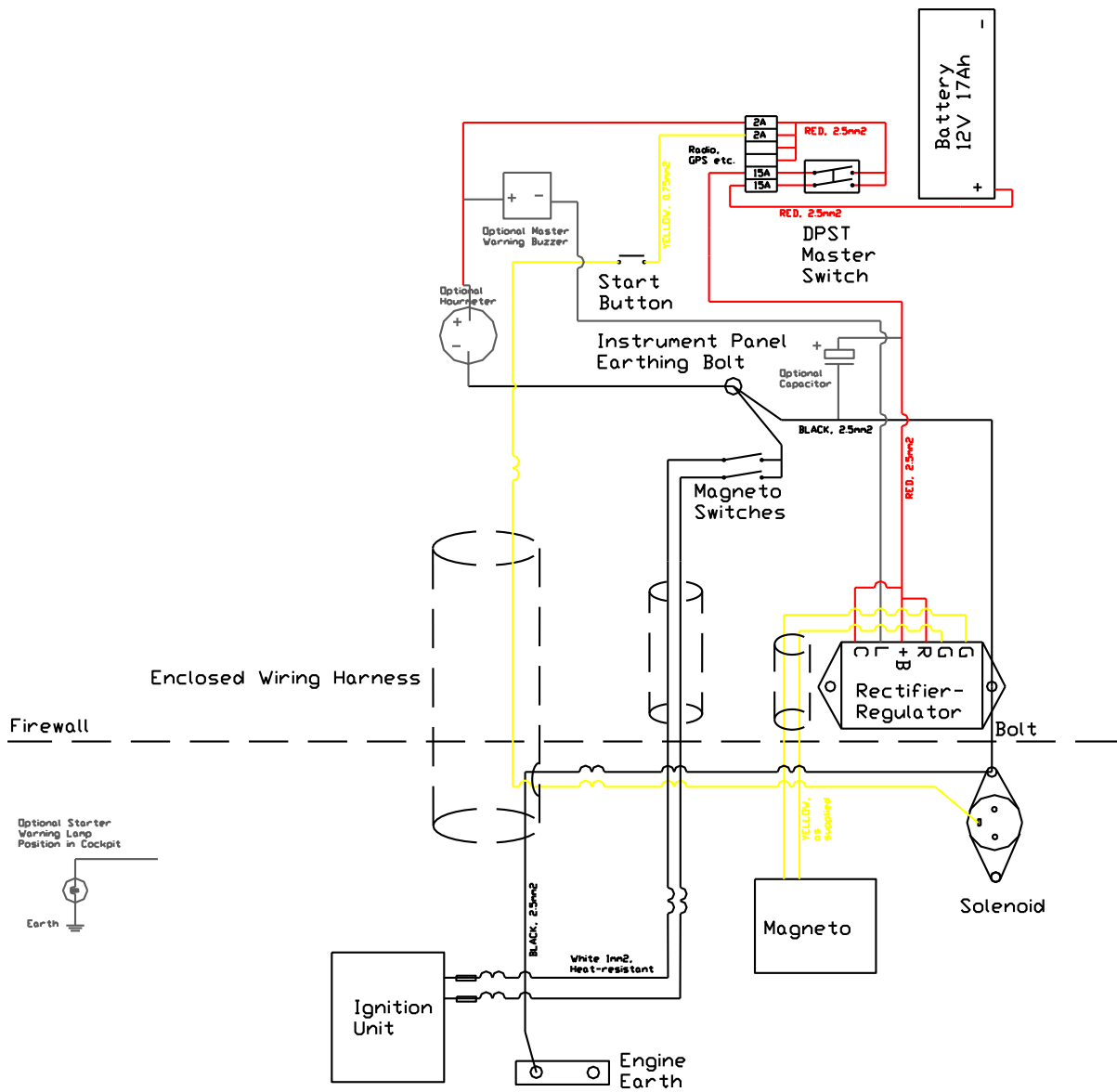


Figure 278 low current wiring schematic, Rotax 912.

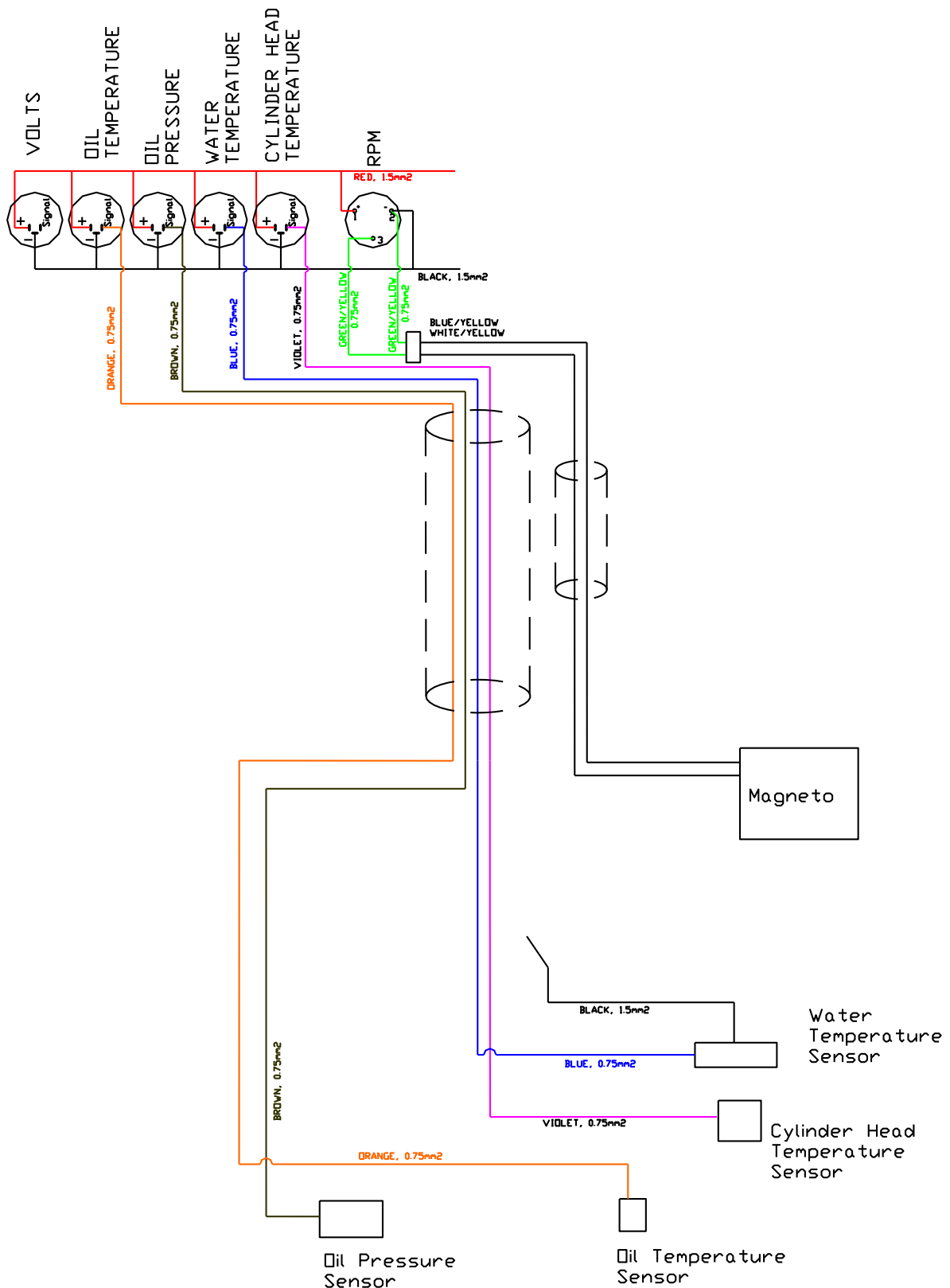


Figure 279 instrument wiring schematic, Rotax 912. (note that later engines have 'wet' temp senders on cylinder heads and what was previously CHT measurement is now coolant, and separate coolant temperature gauges are not required. Also latest wiring looms in the engine installation package include magneto (ignition) wires, and RPM within the made up loom, but Oil pressure is a separate loom).

## 16.1 Soft start wiring

912ULS engines after 2013, incorporate an 'easy start' system. This retards the ignition on both mags for a few seconds at start up. To enable this system the engine is wired to the start solenoid. A separate loom is supplied by Rotax for this with new engines consisting of two wires with connectors pre applied at one end . See below the explanatory wiring diagram from the Rotax manual.

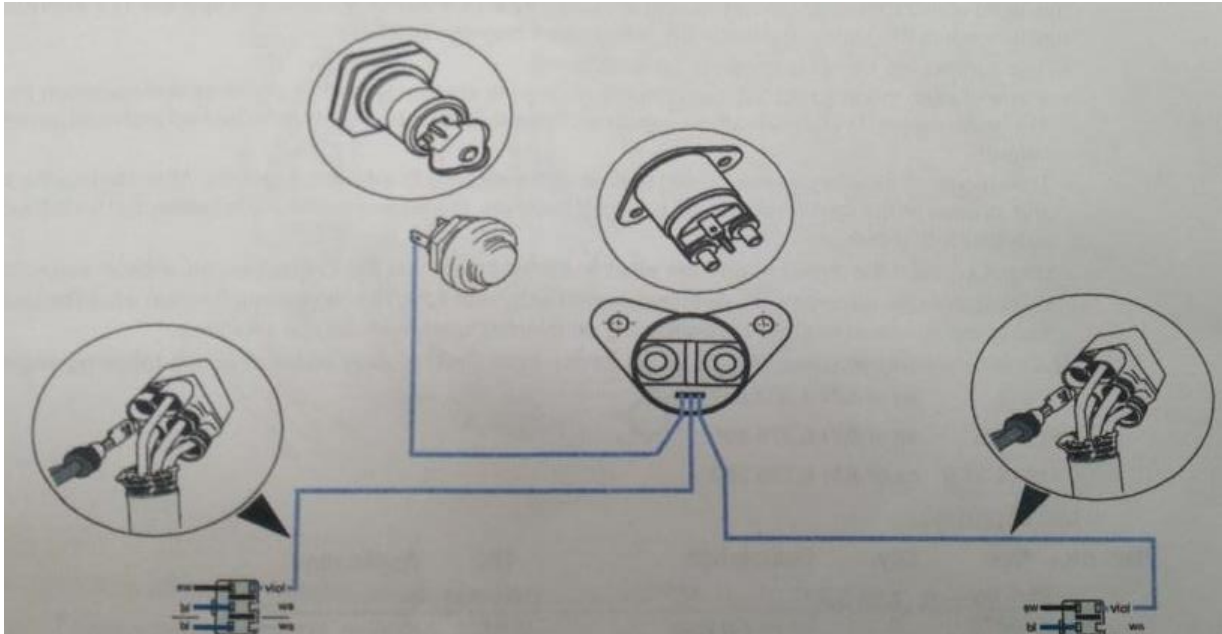


Figure 280 – 'Easy start' wiring diagram

It is basically two leads that come off the solenoid spade connector and insert in the plugs as shown above and also as shown below – the leads are the purple ones in the picture (but are black in the Rotax pre made loom) and connect to the light purple / 'violet' wires. Plugs will need releasing from the clips to gain easy access. or may come pre inserted.

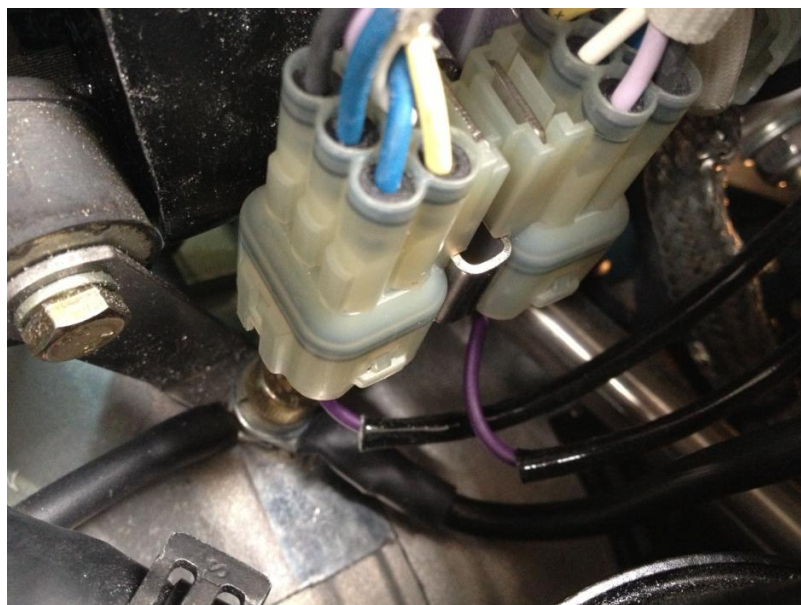


Figure 281 – connector plug wiring

## **16.2 Wiring General Points**

**A ready-made wiring loom for Rotax standard temp and pressure senders, RPM and ignition, as well as main battery leads are included with the engine installation package for the Rotax 912.** The instructions on wiring assume you have either bought this, or are wiring it yourself in the same manner. There are many choices for instruments, engine monitoring systems and avionics and their associated wiring requirements, so you may have to design and make your own looms in accordance with their specific instructions.

If you do not have a basic understanding of electrical systems it may be advisable to buy an introductory text on electrics, especially if you are not using the ready-made loom, or are adding extra equipment. This will serve you well throughout your flying career, not just whilst wiring your Nynja!

When making connections, crimping is generally the quickest and best method. Soldering may seem attractive, but introduces fatigue points and so is not generally recommended.

Crimp tools: you get what you pay for. This is a good moment to spend as much as you dare, your crimps will be better for it! Alternatively, you may be able to borrow or hire a decent tool.

Keep all wiring neat, and ensure that no bare metal connections are visible which may lead to short circuits. Heat shrink tubing is neater than insulation tape for this job! It is available from Maplins, electrical and car accessory shops etc..

Secure the wiring with cable-ties, P-clips or similar, ensuring that it remains clear of all moving and vibrating parts, and is protected from chafing against sharp edges.

Also ensure that the wiring cannot be accidentally damaged or disturbed by pilots' feet, baggage etc..

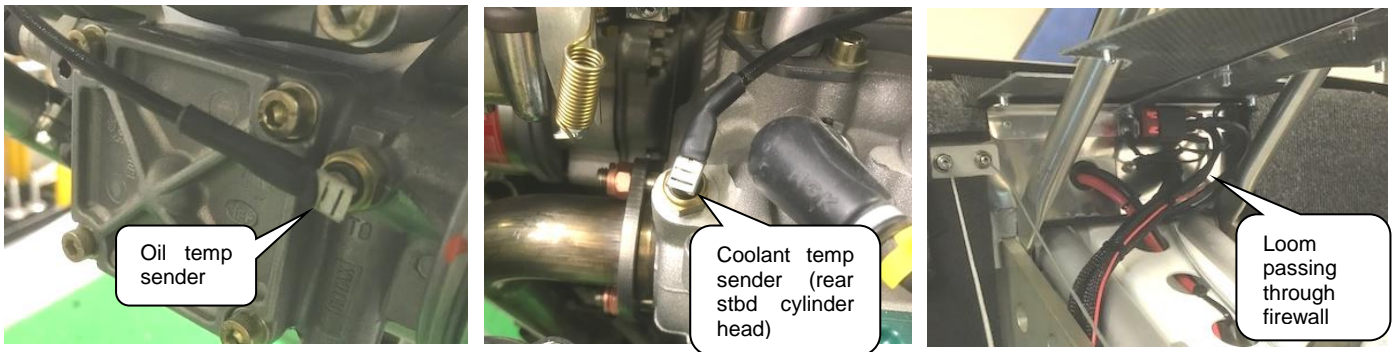
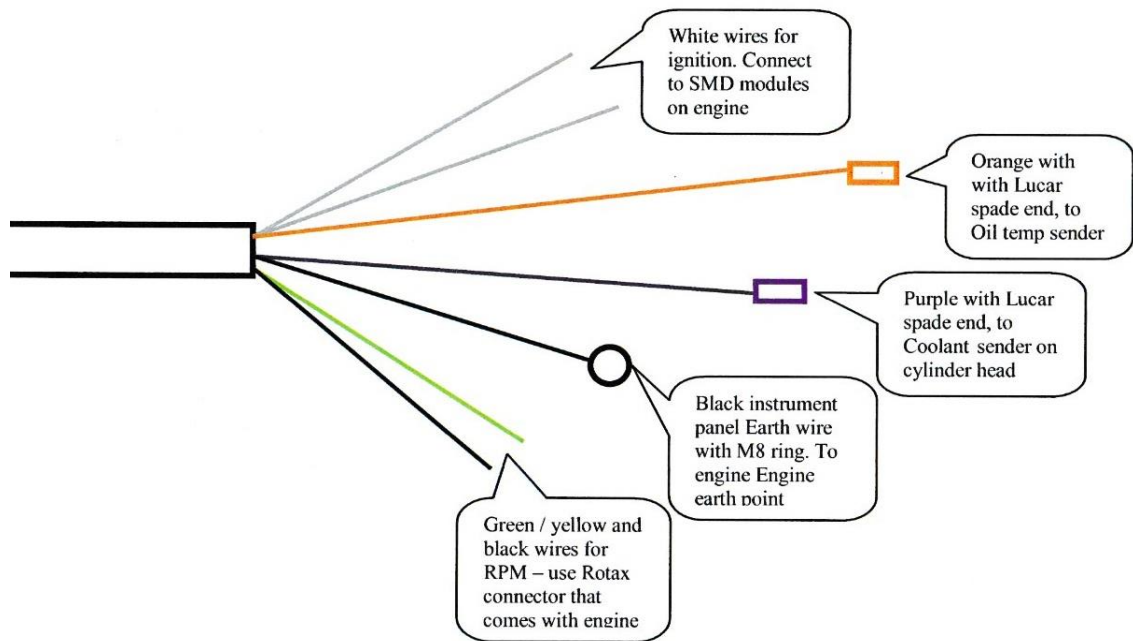
## **16.3 Low Current and Instrument Wiring**

The low current wiring consists of that for the instruments, master switch and magnetos, plus other ancillaries such as a radio.

- a) Read the instructions which come with the engine and the instruments.

*BMAA TILs 7 and 27 may be useful reading too.*

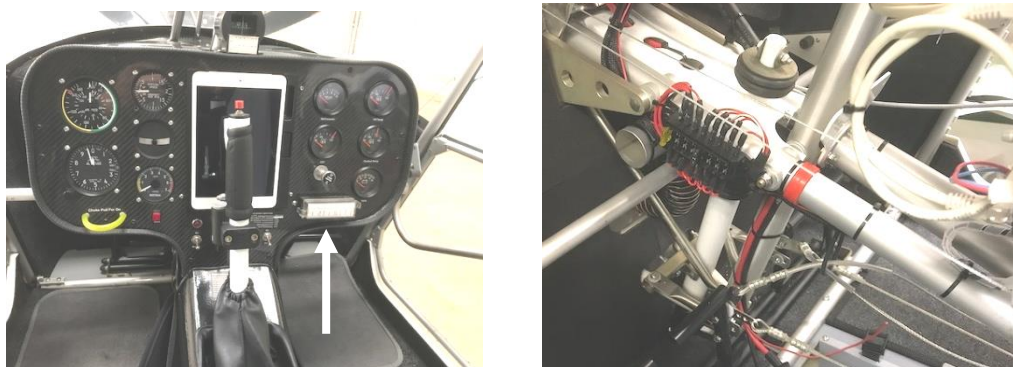
- b) A Pre made loom for engine temp senders, RPM and ignition is included in the Engine installation kit for Rotax 912. Schematic below:



**Fig 282 – sender, RPM and ignition loom**

- c) The oil pressure sender wires are supplied by Rotax with new engines with a made up plug on one end. Run this neatly alongside the other looms through the firewall.
- d) The fuse box can be mounted through the instrument panel for easy access – as shown below, or if panel is full of instruments and space is tight may be mounted elsewhere.

*The contacts can be conveniently connected together, where required, by drilling one hole through each of the protruding contacts in a line and soldering a length of solid wire into the holes.*



**Figure 283- fuse box positions (note right hand picture shows fuse box of different type with connectors exiting sideways).**



- e) The connections on the cabin side should be made according to the instrument instructions and the electrical system schematic.
- f) A common earth bolt can be fitted to provide a convenient earth point for the instruments and other connections.
- g) All switches in aeroplanes should be UP for ON (in the sense of running, powered etc.).

*Note "On" labelled on the magneto (ignition) switches is actually OFF as far as the engine is concerned, as the magnetos are grounded to prevent operation.*

*For versatility and commonality the toggle switches for master and ignitions supplied in the engine installation kit are the double-pole double throw (DPDT) type. Study if necessary to fully understand how these switches work and should be wired up..*

*The connections on the engine side should be made according to the engine installation manual and the electrical system schematics.*

- h) On the 912 the optional capacitor shown in the wiring diagram and the Rotax installation manual may be fitted if desired, although it is rather bulky.

*This has two uses: if you experience interference with your radio through its power supply from the regulator, the capacitor will reduce this by smoothing the supply a little, although the battery already does most of this and a radio power interface does the same thing. The capacitor also provides a fail-safe against accidental disconnection of the battery whilst the engine is running, which would otherwise cause the regulator voltage to rise with possible damage to instruments, radio etc.*

*Disconnection would occur either by blowing of the fuse to the battery or if the wire to terminal C on the regulator were to become disconnected.*

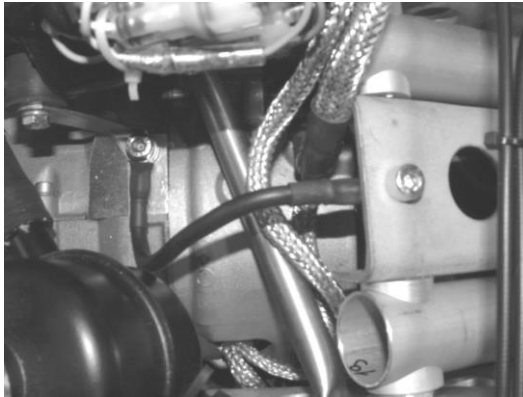
*A suitable capacitor is available from Rotax/Skydrive. If only protection from disconnection were required, a smaller capacitor could be used at your own discretion.*

- i) Other optional items are shown on the wiring diagrams: they are an hour-meter, a master-switch warning buzzer, and a start-button warning light.
- j) Additional systems such as GPS, radio etc. should be individually protected by fuses of the appropriate size.

## **16.4 Battery**

- a) Pre made cables for Battery to Engine Earth, Engine Earth to frame Earth, Battery to starter Solenoid and Starter Solenoid to Starter Motor are included in the Engine installation kit.
- b) The battery should be installed in its supporting box in the hole in the floor between the central cabin tubes, underneath the dash board.
- c) Secure with the webbing strap.

- d) Ensure that the engine block is well earthed to the airframe,
- e) Figure 261. Here an extra hole has been drilled in the engine mount. Alternatively, attach the earth to one of the existing bolts if enough thread length is available.



**Figure 284 engine to airframe earth.**

- f) Attach the earth cable to the battery negative and to the bolt on the engine block in the same location as shown in fig 261 above

*Route the cable through the firewall in the vicinity of the other wires.*

- g) The recommended position for regulator and solenoid are on the firewall to port of the port Carburettor.



**Figure 285 912 solenoid and regulator**

- h) Ensure that the regulator is properly earthed.

*If fitting regulator and solenoid to the firewall, beware that the aluminium firewall is not a good earth – it may work initially but could break down over time – leading to mystery faults! Use separate earth wires from the securing bolts to a main earth point.*

- i) Ensure the battery terminal boots are firmly in place, and that the rudder stop cables are held away from the battery by their bungee restraint.

***Failure to do this may result in a short circuit and fire!***

## 17 Windscreen and rear windows

### 17.1 Windscreen

Do not allow threadlock (Loctite etc.) or other solvents to come in contact with the Lexan as it will damage it severely.

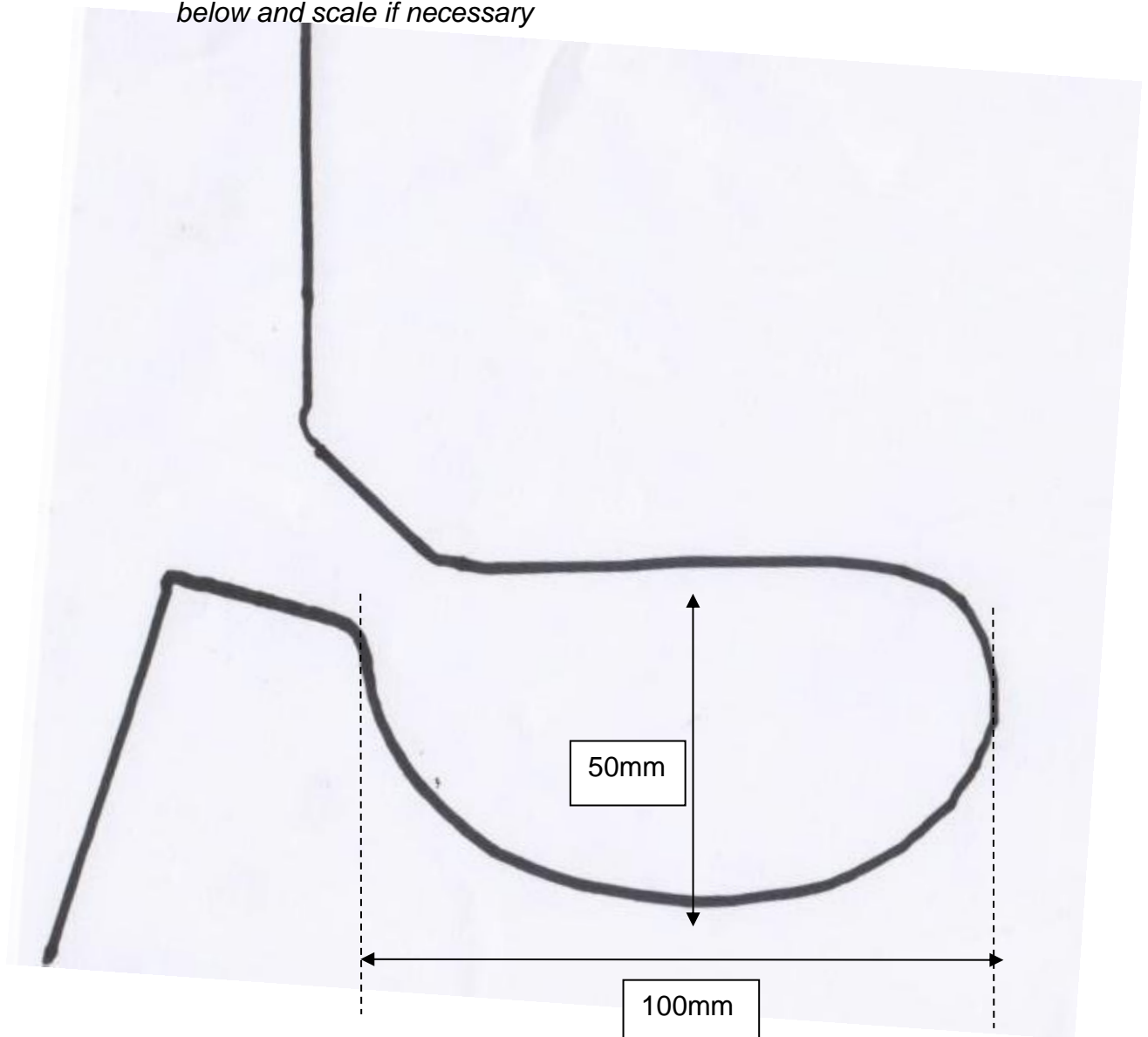
Fitting the windscreen is best done with wings in place to ensure perfect fit.

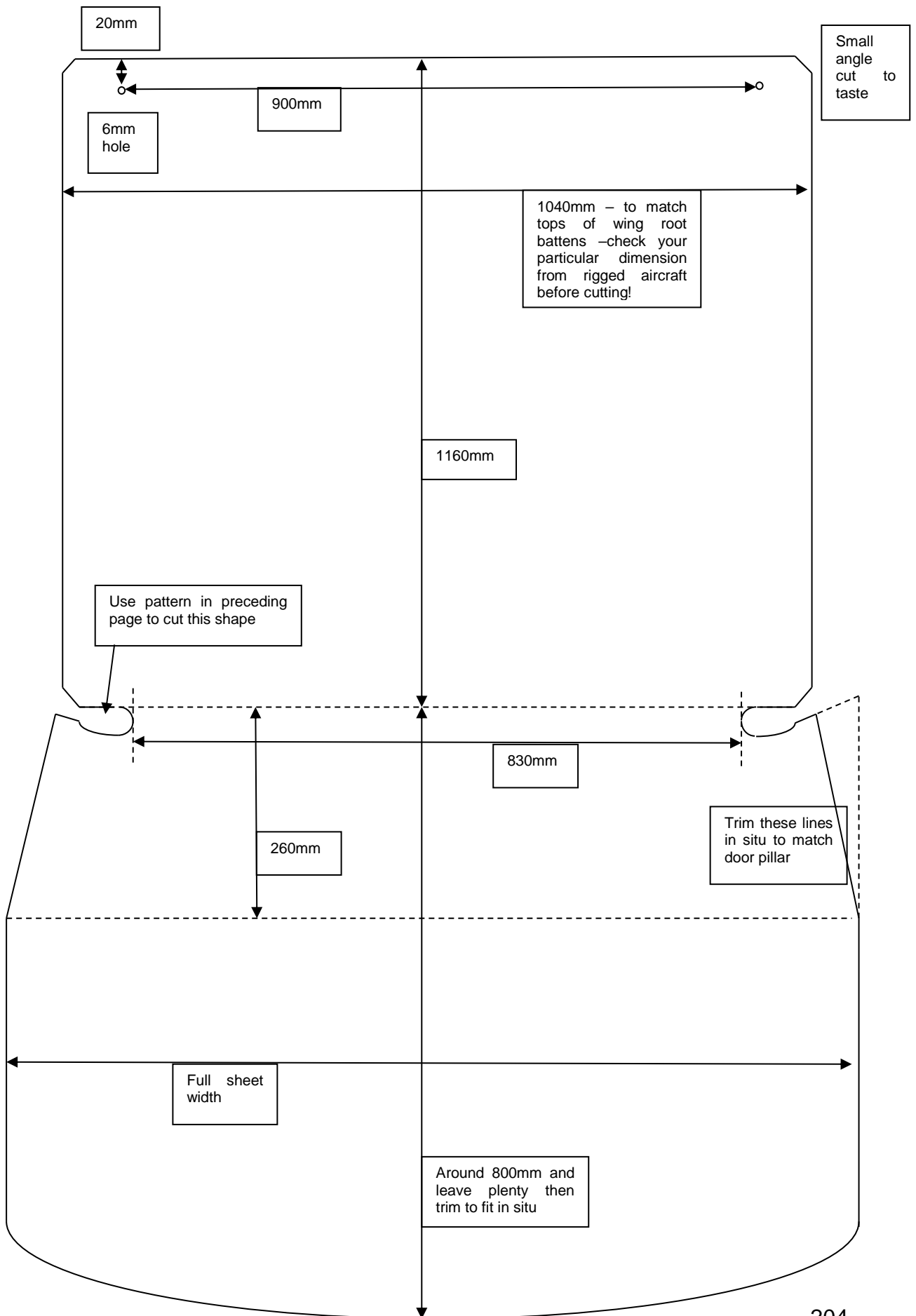
- a) Apply the supplied strips of thin self-adhesive foam strip to the top of the curved tubes TU34 supporting the top part of the windscreen.

*This will reduce noise and vibration.*

- b) The lexans should come marked with the screen pattern. But produced below is a full drawing should you need it:

*The corner patterns should print out full size but use measurements below and scale if necessary*





- c) Cut the main windscreen Lexan sheet to the drawn pattern.

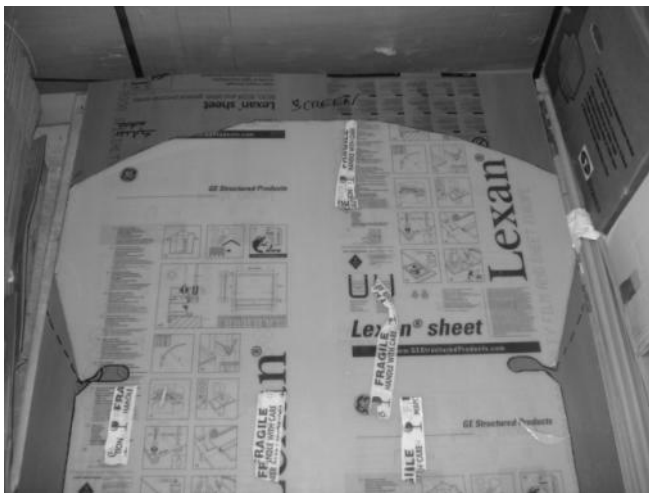
*Cut a little oversize at the front, and sides to start with – these will be trimmed to fit later. (cut oversize especially at the front – by at least 30mm)*

*Draw an accurate centreline on the protective covering film – this will help later to ensure everything is straight and centred.*

*A good tool for cutting lexan is straight tin snips as shown in the picture below. Edges cut with tin snips should be dressed smooth with sandpaper over a sanding block.*

*For more intricate curves a Dremel cutting toll can be used followed by using the sanding drum attachment.*

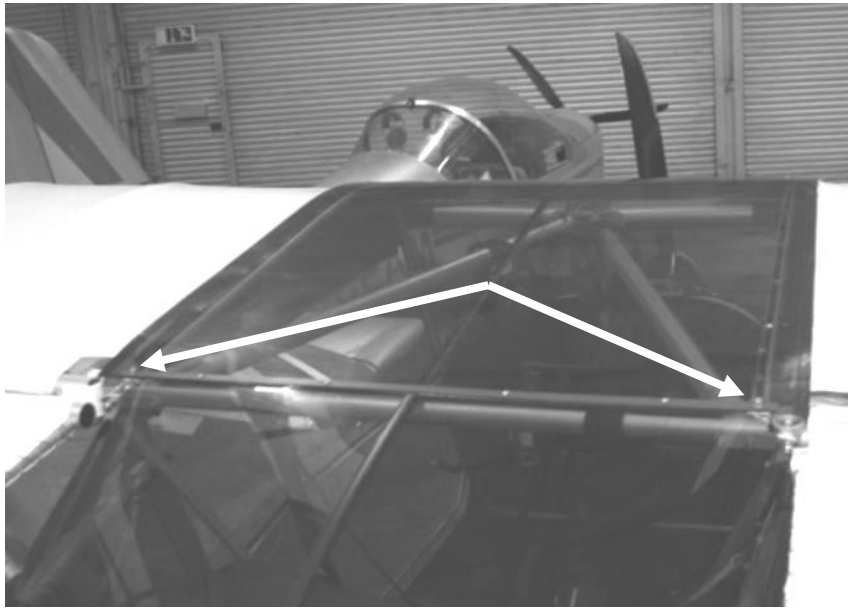
*To trim excess from edges, a Surform tool has been found to be useful.*



**Figure 287 cutting the Lexan to the pattern.**

- d) Drill the two rear holes marked on the rear part of the Lexan.  
e) Lay the Lexan over the cockpit, locating the holes in the Lexan over the two bolts sticking up at the rear of the cockpit.

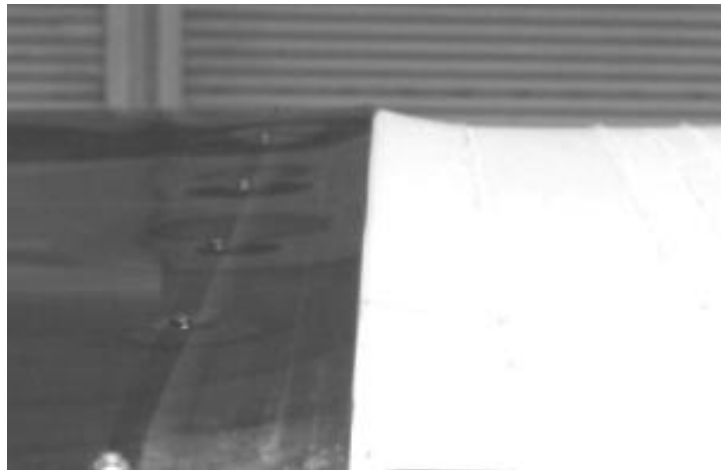
*Check that you have not left the leading-edge securing pins in place, as if you do, and they are incorrectly inserted from the front instead of their proper insertion from the rear, you will not be able to get them out again when you have fitted the windscreen!*



**Figure 288 drilling for the rear mounting bolts.**

*Check that the lexan as fitted is centred and not on at an angle. Adjust the holes if required.*

- f) The lexan is normally a little oversized in width. Mark the sides, remove and cut, so that the edges sit just past the peak of the wing covering root batten by 5mm or so



**Figure 289 lexan edge matched to wing covering root batten peak**

- g) Before rivetting the lexan in position, apply 3mm self adhesive foam strip to lexan edge so it protects the covering from chafing with the lexan (a good seal also enhances flight and stall characteristics). This can be done later, but will require the wings removing to do it.

- h) At the rear fit the rear screen moulding so its top is aligned and flat with the angle of the lexan. Trim so that the seatbelts may pass unhindered under it. Use some rubber berading to edge the slots so seatbelts cannot chafe. Fix in position to the tube using 4mm aluminium rivets. The screen can be fixed into it using 4mm riv-nuts evenly spaced. Use some thin foam between screen and moulding to prevent rattling



**Fig 290 rear screen moulding**

- i) Push the windscreen into position behind the cowling lip, wrap around the sides and clamp into position on the cabin uprights.

*Take care – the lexan is quite springy and if its edge is bashed against the glassfibre cowling edge it can cause chunks to be taken out. Two people makes easier work at this stage.*

*The windscreen pattern is intended to be oversize at the front. Insert the screen and position carefully, mark a cut line aiming for a neat overlap of 25mm. – maybe more along the side if the side pockets are being fitted – look forwards to that section now to see why.*

*Take care that the tubes **tu34** supporting the windscreen do not get knocked out of position, check them regularly, and check that the shape of the cowling remains as it should be otherwise you may build a strange shape into the windscreen and the cowling!*

*The drawn centreline is a useful reference and should end up in the dead centre of the cowling.*



**Figure 291** windscreen over lap inside cowling (note we painted the overlap to match interior fabric trimming.

- j) Rivet the Lexan every 15cm or so to the large curved tubes on the top sides of the fuselage.

*Use the pre-drilled holes, start at the rear and work towards the front of the Lexan.*

*Clecos / skinpins can be used first rather than going straight for rivets.*

*Peel back the securing film so it is not trapped between the TU34 and the lexan and under the rivet heads – it won't be easy to get out afterwards..*

*Use the black 4mm aluminium rivets.*

- k) Get two helpers, one on each side of the fuselage pushing the Lexan tightly into the inside of the curved part of the cowling.

*Make sure there are no gaps, and that the Lexan is evenly positioned with respect to the cabin upright tubes **tu34** on each side, and that these are in their correct positions too.*

- l) While the two people hold the cowling in place, drill holes through the cowling and the Lexan to hold it in place with white 4mm pan head plastic screws, and black plastic domed nuts.

*Check that the cowling has not distorted, particularly with reference to the minimum 10mm clearance from the spinner – the bonnet must be secured in position before securing the lexan, or it may not fit afterwards!*

*The curvature of the cowling can be increased slightly by lifting it in the middle before fixing the windscreen, to increase space for the carburettors etc. . Don't over-do this however, as you will distort the rest of the cowling.*

*Space the screws evenly, every 100mm or so.*

*Start with a hole in the exact centre (this will be used later for the screen bracing batten – don't put a screw in yet).*

*To finally fix the dome nuts, use a drop of superglue inside as threadlock – don't do this until you are ready for a final fixing – it may*



*be rather permanent – we have managed to unscrew them, but they might need cutting off.*

- m) If using the two piece doors drill and rivet the sides of the windscreen to the cabin uprights **tu34**.

*The spacing of the rivets should be around 60mm or so. You can use the silver aluminium 4mm rivets. Trim the excess Lexan so that it is even with the rear of the tubes.*

- n) If using the one piece doors proceed to that section of the manual and fit the glassfibre strip as shown.
- o) Locate the windscreen roof centre batten – you should have sorted it out and put it aside when fitting the wing battens. Find also the screen centre batten and joiner plug.

*Cut the end off the roof centre batten to expose the hollow tube end. Fit the small tube plug inside the end of the tube so that half its length is exposed. Plug onto this the screen centre batten tube*

*Curve the ensemble to match the curve of the roof and windscreen as precisely as possible. It may be necessary to trim the length of the extension batten to fit.*

*Drill the roof batten (not the screen centre batten) matching the spacing on the adjacent windscreen supports*

*Apply the thin self adhesive foam strip to the batten ensemble where it will touch the lexan.*

*Fix into position. While one person holds the batten against the underside of the top of the windscreen, another person can drill from the top, through the Lexan.*

*Use 4mm black aluminium rivets to fix to the roof area Do not use any rivets down the forward windscreen portion Secure the front end of the screen centre batten using a 4mm bolt to pass through the glassfibre upper rear cowling piece, the lexan and through the batten.*

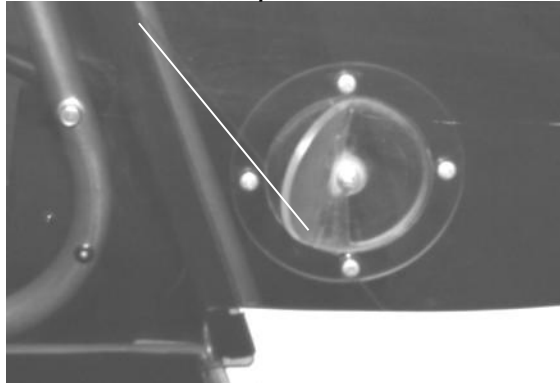


**Fig 292 screen centre batten**

- p) At the rear the centre batten can be slotted into the rear screen moulding make sure it is tight or it will rattle!
- q) With the left over Lexan, cut a triangular piece to fit in the corners of the windscreen and tube **SKR34**. Secure in place with rivets through tubes **SKR34** and through the cowlings.

*A pair of vents such as those available from Light Aero Spares may be fitted across the joins if desired.*

*Dress the rear side edges of the windscreen smooth with a sanding block. Apply two lines of 1x10mm self adhesive foam strip to the edge, where the door will overlap later.*



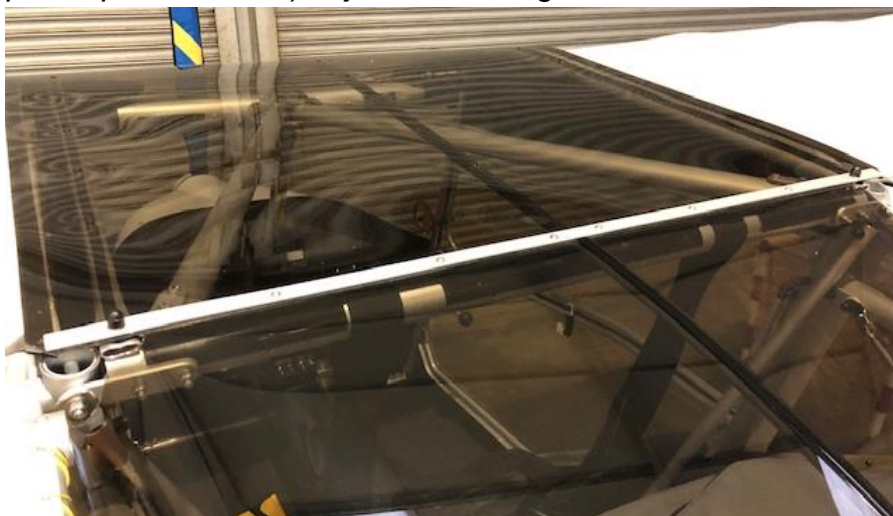
**Fig 293 windscreen side fillet, and vista vent**

## **17.2 Rear windows**

If intending to fit the rear thermal screen option, plastic angles will have to be fitted at this stage - read ahead now to section 27.

- a) Cut the windows to the pattern. Leave a little oversize at first.

*Overlap the rear windows sliding underneath the rear edge of the windscreen by around 25mm and passing over the cabin cross tube centre. Make a capstrip from some 2mm aluminium strip. We used a H section moulding (DIY shop item painted black) to join left and right rear screen halves*



**Fig 294 windscreen rear edge / rear window interface**

- b) Use the black 4mm plastic screws and black plastic dome nuts to secure to the glassfibre fairings.

*Before any fixing the windows will need carefully cutting and dressing to fit. Clecots/ skinpins very useful during the fitting / fixing process.*

*To ensure accurate sizing and positioning of the holes for the flap rods, a useful technique is, with wings fitted and flaps connected, to make a card template which can be taped into position and hole cut and finessed to match travel of flap rod when flaps are extended. Mark the position of the template, and then with lexan finally fitted to the fuselage the template can be overlaid and positioned to the reference marks, and hole marked and cut in the lexan.*

- c) On the side the windows will need carefully marking and cutting to fit around the brackets on the end of the TU2 upper fuselage tubes.

*A dremel cutting wheel and sanding drum makes light work of this.*



**Figure 295 lexan cut around end of TU2 and template to get exact hole shape**

- d) Use rivets to secure to the cabin rear upright TU 6.

*Trim the edge of the lexan to be flush with forward edge of tube. Use the trim beading over the exposed edge. The rivet line should be covered with a strip of 3mm self adhesive foam*



**Figure 296 finished installed rear window**

## 18 Doors

The doors should be made to fit, with the wings in place for best results and fit. Care with cutting and positioning the doors will reduce the number of draughts!

Check and double check the fit before cutting the parts, especially the Lexan. The exact measurements depend upon a number of factors, Use the patterns as a guide only.

Before making the doors, decide which wing root enclosure system you will be using – and if using the glassfibre one, fit this first .

### 18.1 Keeping out the drafts.

Supplied in the kit are two big pieces of glassfibre angle designed to be used as wing root closures and gaps seals extending to the wing undersurface.

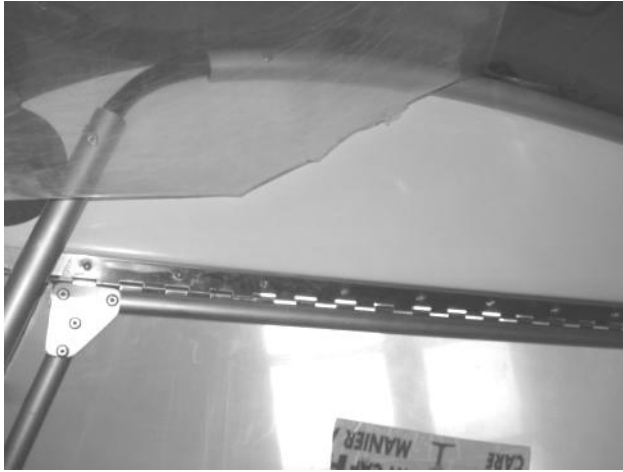
However they weight around a total 1kg installed (500g each). In the UK demonstrator to save weight we did not use these. We extended the angle used on the door tops to meet the wing undersurface. This can be done by using some spare lexan or using a strip of glassfibre cut from the big angles rivetted in place on the aluminium angle.

We then made a wingroot enclosure from some light fabric, velcroed in place to the cabin roof tube 34 and the edge of the aluminium angle, as an optional fit and not necessary to count in the basic aircraft weight. This piece is purely cosmetic and the drafts are sealed by the strip on the angle. This is included in UK kits.

So you decide which way to do it on your aircraft!



**Figure 297** fabric enclosure, and extended angle to close gap to wing undersurface rivetted to top of angle.



**Figure 298 large glassfibre angle enclosure.**

To fit the large glassfibre enclosure angle – you should do this before making the upper door, so that the door angle can sit flush with it.:

*Trim upper surface to cut marks to fit as shown in fig 249 above.*

*It sits against the TU34 upper tube and rivets to it with 4mm aluminium rivets*

*Before final trimming and riveting Fit the wings and position the piece so that the glassfibre lower edge sits flush under the wing root. This edge can then be trimmed to an even overlap.*

*The aluminium door angle should be butted up underneath, drilled to fit in that position.*

## 18.2 One Piece Door

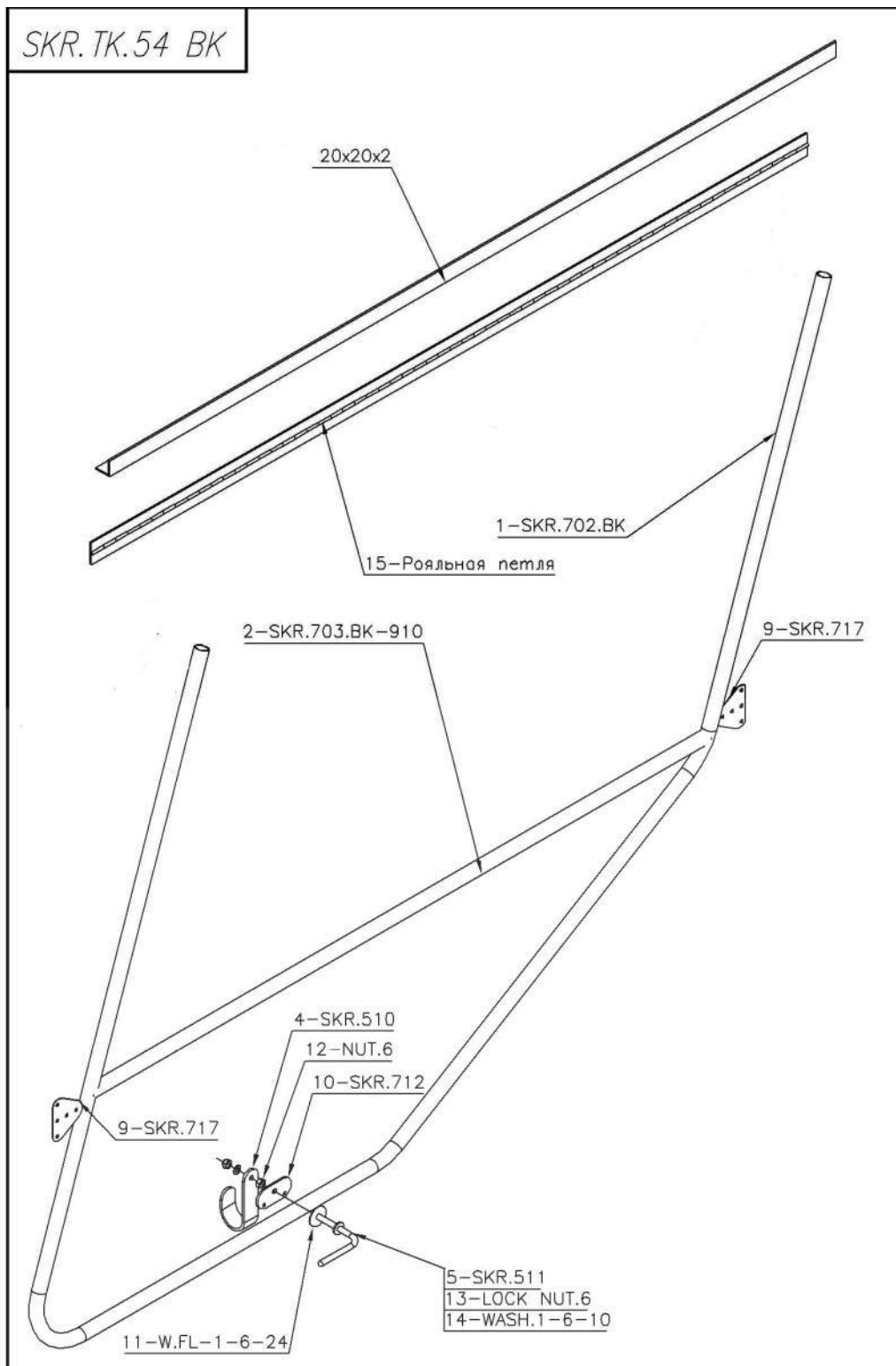


Figure 299 one piece door frame.

### 18.2.1 One Piece Door Frame

- a) The door is hinged with a length of 'piano' hinge. This is attached to a 20x20mm piece of aluminium angle. This angle has its upper horizontal edge facing outwards, at the same level as the wing undersurface

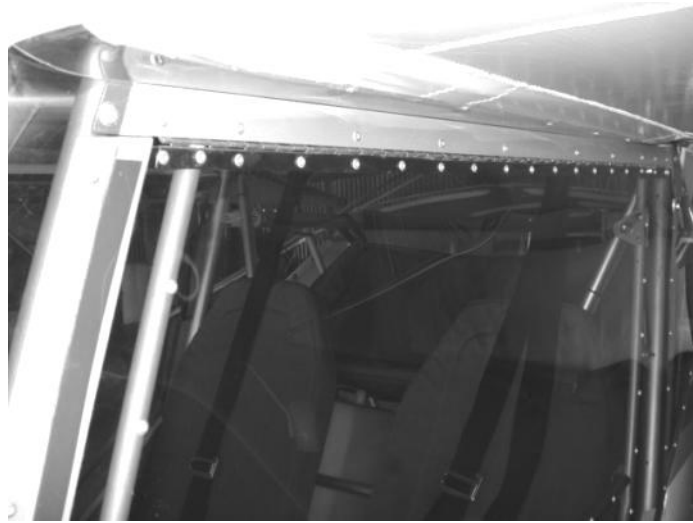


Figure 300 upper hinge

- b) Offer up the 20x20 angle and align it level with the wing undersurface. Mark the position of the tube centres for TU34 and TU 6, then drill the centre of the angle in these positions – 4mm diameter in TU34, and 5mm in TU6..
- c) Offer it up again , mark and drill the TU34 and TU6 to match, and temporarily fix into position.
- d) When using the one piece doors the front cabin upright TU34 is fitted with a glassfibre strip for the door glazing to seal against when the door shuts.

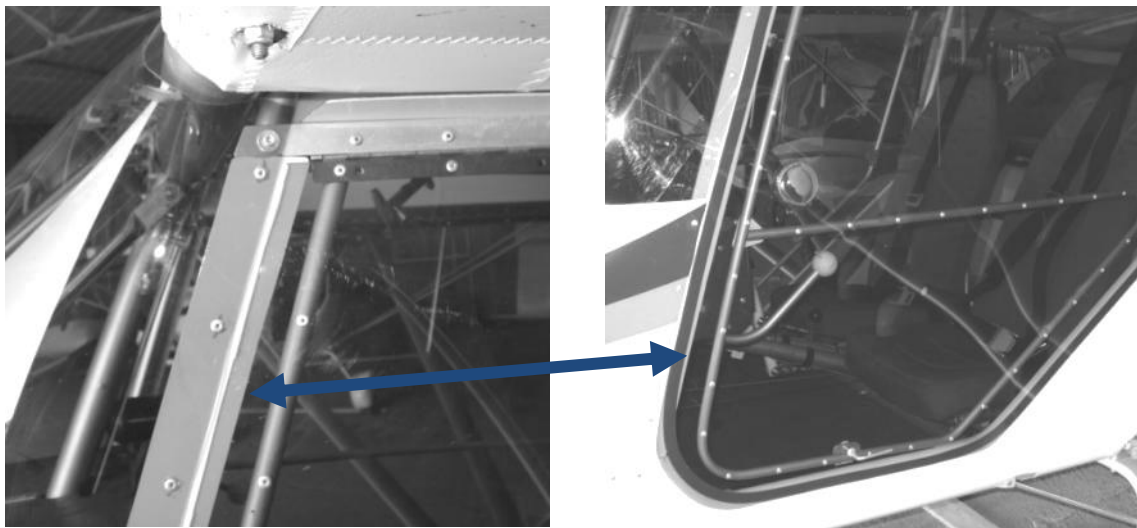


Figure 301 Glassfibre sealing strip

*If not fitted already fit this now. It runs the whole way up to align with the joggle in the door sill. Trim and dress the edges of the windscreen and cowling moulding to align just beyond the centre of TU34 – leaving enough edge distance for the rivets.*

- e) Fit the piano hinge now to the 20x20 angle trimming its length as necessary.
- f) Take the door frame and offer it up to the opening.

*Aim for a final position with an even spacing from the cabin uprights TU34 and the top of the door sill and rear upright TU6*

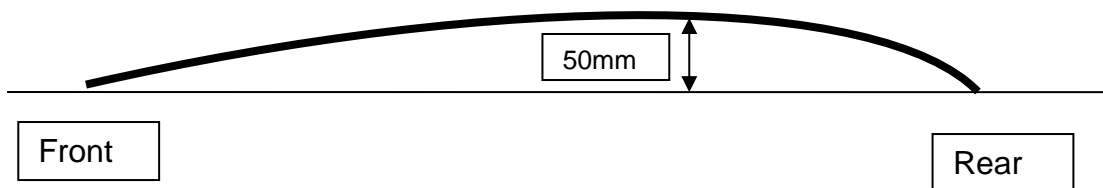
*Carefully bend the frame as required to ensure the best fit.*

*The relative positions of the rear cabin uprights **tu6** and the cabin uprights **tu34** requires that the rear edge is also bent outwards slightly relative to the front.*

- g) Mark the tops of the door frames and cut, just below the hinge line. Drill the hinge and door tubes with 4mm holes and secure with cleco's/ skinpin's.

- h) Fit the central curved tube.

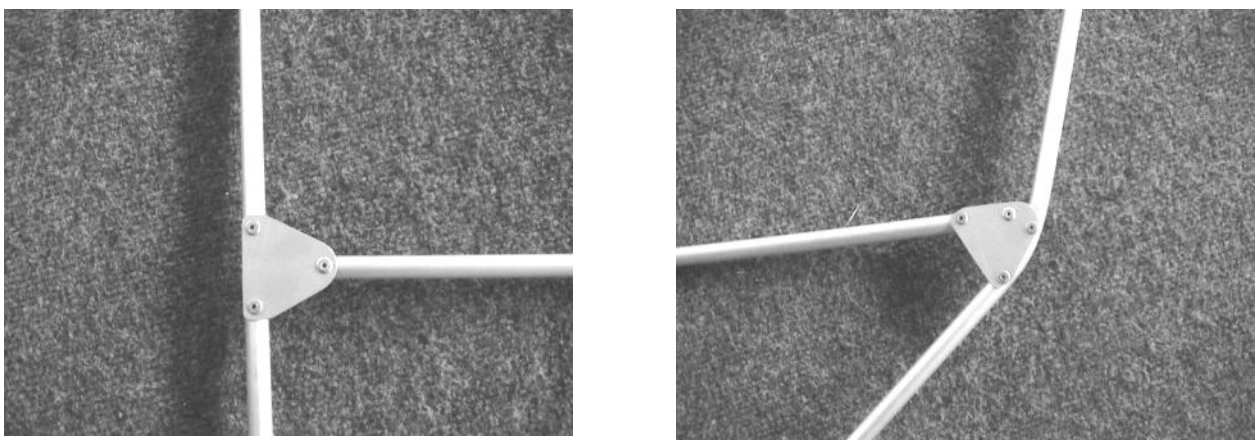
*The curve should go towards the rear of the door – like a backwards aerofoil. Check the curve with a straight edge – max camber should be 50mm.*



**Fig 302 – door curve**

*It should be positioned with the rear edge just above the bend in the door frame, and the front edge positioned so the tube is horizontal or nearly so matching the lines and overall shape of the aircraft. If it needs trimming – trim from the front edge.*

*Fit in position using the gusset plates shown in drawing Fig 285 and 286, with 4mm aluminium rivets.*



**Fig 303 front and rear gusset plates**

- i) Do a final check of fit and operation of the doorframe.



## 18.2.2 Fitting the Lexan

- a) Cut out the Lexan sheet from the patterns.

*Use a large pair of tin snips. The patterns are supplied as a guide, and your individually constructed doors may vary slightly, so cut oversize initially to be safe.*

- b) With the door in position offer up the Lexan and mark some reference points to align with the door frame.

*For now it should be positioned accurately against the hinge, and centred to provide an even overlap all the way around its other three sides.*

- c) Before riveting mark and drill the holes on the doorframe.

*Use a nominal rivet spacing of 60mm. Try to drill in the centre of the tubes or it will pull the lexan out of shape. Lightly marking the centre by drawing a long flexible metal straight edge across the frame can help.*

- d) Drill and rivet in place the lexan using 4mm aluminium rivets.

*Remove the protective coating from the inside face of the Lexan, leave it in place on the outside but remove it using your fingernail around each point to clear the rivet heads.*

*It is advisable to fix with cleco's/skin pin's first before rivetting*

*Work from the upper front corner, and rivet the front edge first. Follow this by riveting the lower edge. Due to the curve in the central cross-piece the rear edge will have to be worked around the curve, to avoid a wavy edge.*

*It may be necessary to drill out some rivets and reposition the tension in the Lexan slightly to get the best fit (cleco's/ skinpin's used first will help avoid this). Do not be tempted to put more curve in the central cross piece to give greater shoulder room or you will turn this into an impossible task! Finish by riveting the upper cross piece and then the central cross piece.*

*When drilling angle the drill slightly away from the last rivet. When squeezing the rivets bring the rivet upright. This then applies some light tension to the Lexan and prevents the Lexan bulging between rivets. Take care when drilling to ensure the tube is drilled centrally.*

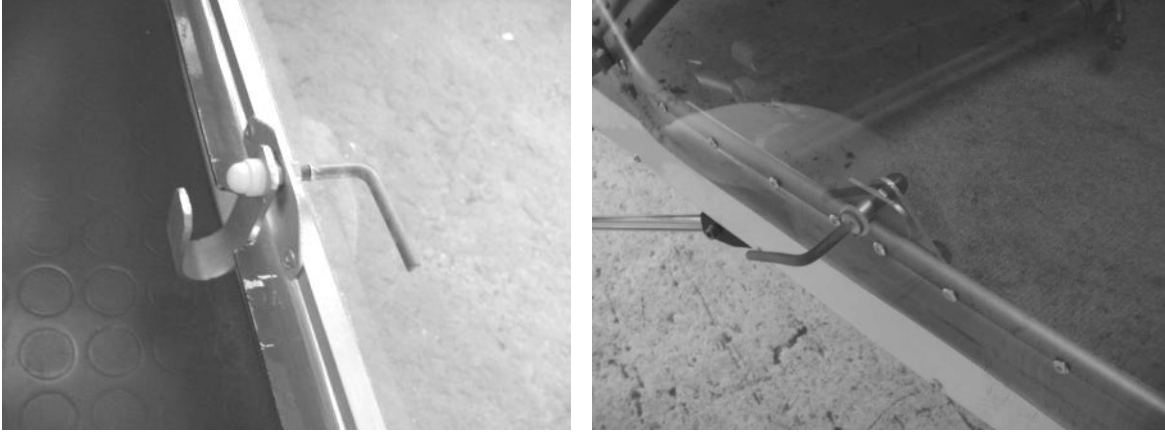
- e) Fit the door and mark carefully the overlap for cutting to final position.

*The front and lower edge should be cut to match the recess. The rear can overlap the rear window, or another glassfibre strip can be used.*

### 18.2.3 Fittings

- a) Fit the lower catch assemblies as per Figure 282 and 287.

*Use two 4mm steel rivets to attach the aluminium plate to the doorframe.*



**Figure 304 lower catch.**

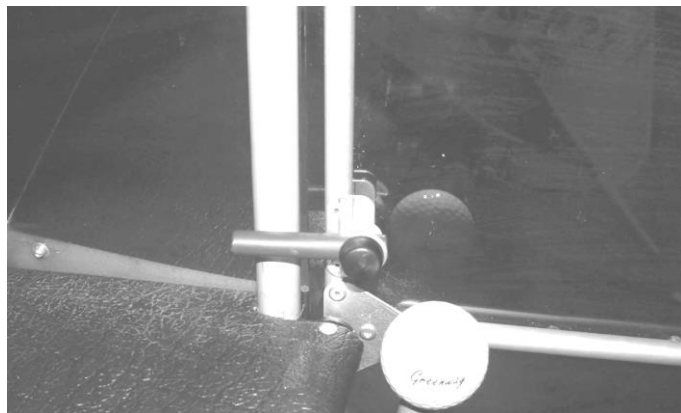
- b) The inner edge of the sill should be positioned so the latch it a tight fit to lock into place.

*The fibreglass can be filed a little to achieve a slight indent to prevent the lever from inadvertently rotating to the open position, or an Nylon or aluminium piece can be riveted on to protect the fibreglass from wear.*

- c) Position the front catch just above the gusset plate for the forwards edge of the centre cross piece.

*UKMOD: this is an additional catch for UK aircraft to secure the front of the doorframe to the cabin uprights **tu34**.*

*It should be fitted with the bolt tightened to ensure enough friction to prevent inadvertent rotation.*

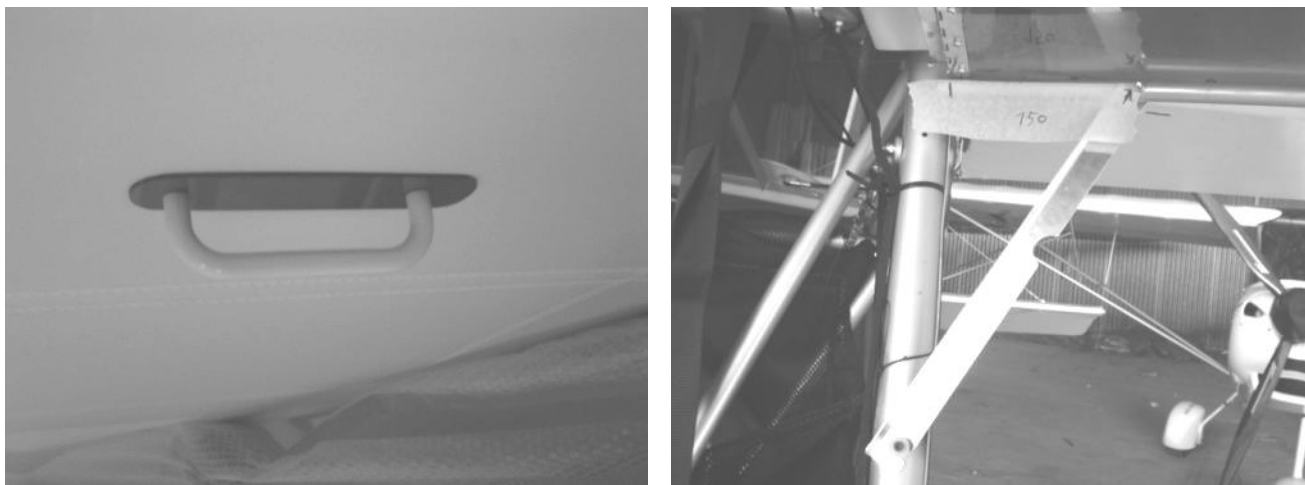


**Figure 305 front catch.**

- d) With the wings fitted and in place fit the open door keeper, Figure 256.

*This should be positioned so that the door handle can be rotated into it. It is fitted to the wing surface with two screws (cut these to length) with spreader plates made from two rectangles of scrap Lexan 30mm X 150 (15mm radius at each end) either side of the wing fabric. This job will require two people or very long bendy arms!*

*Alternatively a stay can be fabricated or small gas filled struts fitted to hold the door open*



**Figure 306 door open keeper, and example of an alternative fabricated stay.**

## 18.3 Two Piece Door



Figure 307 two piece door overview

### 18.3.1 Lower door frames

- a) Ensure that the aluminium door hinges have been fitted and riveted to the cabin uprights **tu34**.

*Remember that the doors open outwards and forwards, so the hinge “bulge” needs to be on the outside.*

*Hinge should be fitted so top edge is 25mm below the top edge of the glassfibre cowling. This should then match the windscreen lower edge and but against or near it. Lower edge should fit level with the top edge of the floor pan moulding sill.*

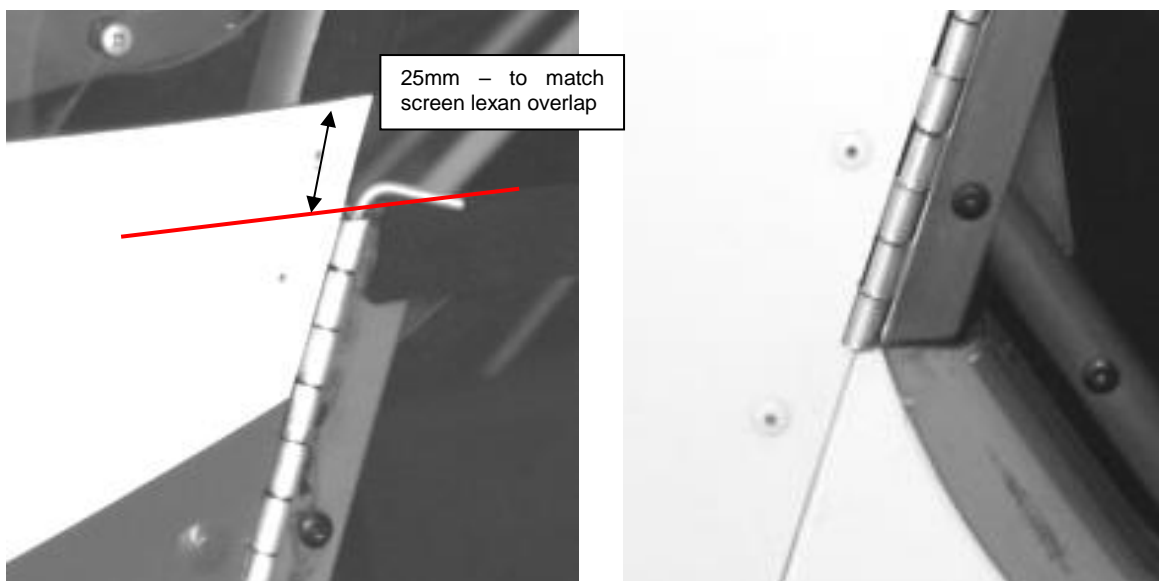
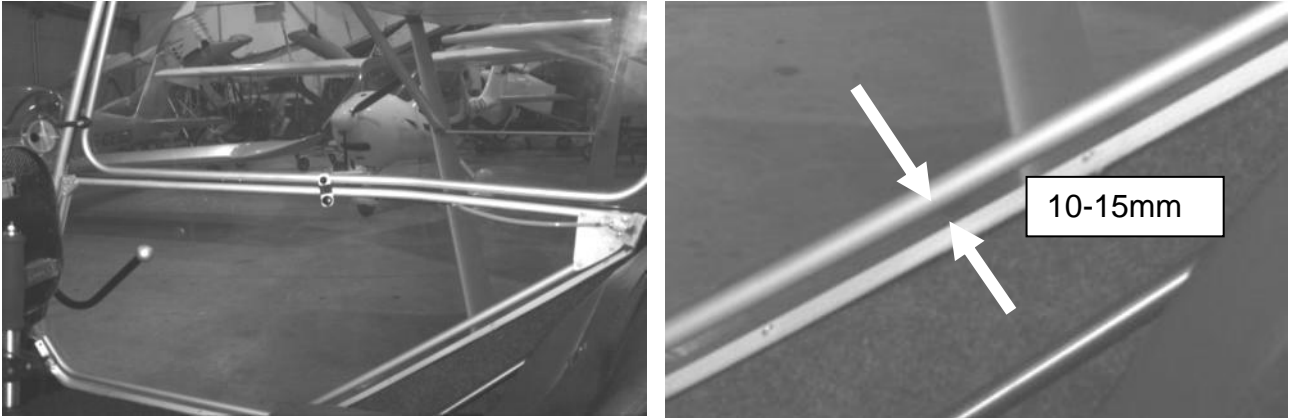


Figure 308 upper and lower hinge positions

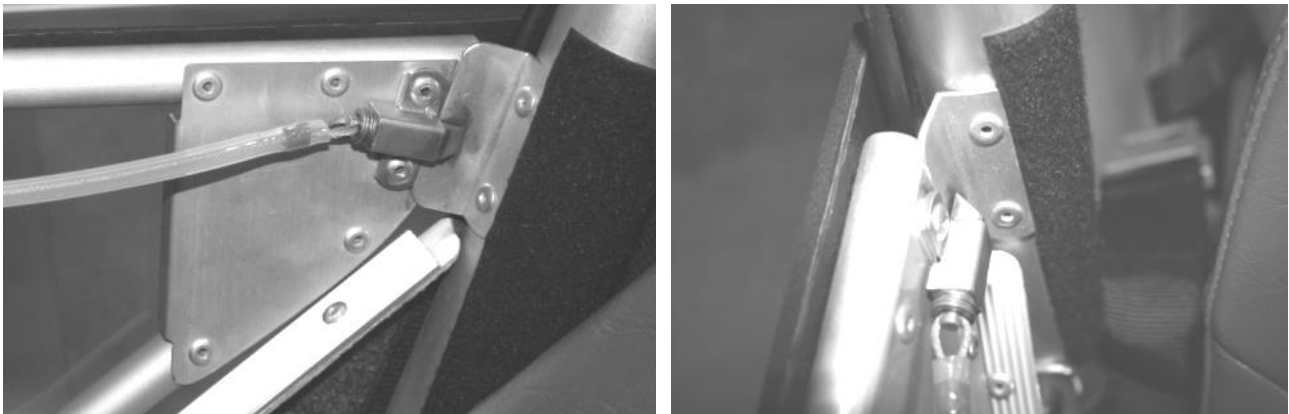
- b) The frame tubes are supplied slightly over long at each end and must be trimmed to fit.
- c) Start with the lower tube first and offer it up into position.

*It should be an even fit inside the opening spaced 10-15mm. make up some spacers this size and tape them around strategically around the opening so you can rest the tube in position and achieve this.*



**Figure 309 tube spacing**

- d) Make sure that the rear part of the door frame is close enough to the rear cabin upright to allow the door catch to reach 5-10mm overlap with catch plate.



**Figure 310 door catch overlap**

- e) When happy with the positioning trim the forward tube end to fit

*Trim it to match the vertical line of the hinge*



**Figure 311 front end of lower door tube – shown with door open.**

- f) The rear upper end should be trimmed to fit below the top tube. Offer up the rear gusset plate as a guide to where to cut the tube to fit.



**Figure 312 rear gusset plate and rear end of lower door.**

- g) Drill the front end of the tube and hinge and secure with a cleco / skinpin.

*Make sure the tube is in exactly the correct position before drilling and not rotated out of alignment with the opening.*

- h) The top tube must next be trimmed to fit.

*It is important that the outwards bend matches the position of the bend in the upper door frame. Get this now and tap it in position so that this can be ascertained and the tube trimmed to fit accordingly.*

- i) Now fit the lower door frame together.

*Start with fixing the top tube to the hinge by drilling and fixing with a cleco/ skinpin. Ensure that the tube is correctly orientated with bend outwards and not rotated upwards or downwards.*

*Next with the door frame taped in the closed position, drill and rivet the rear gusset plate into position. Allow room to fit the catch, and but up against the catch plate later later – see Fig 262 above and Fig 272 later. Use 4mm aluminium rivets. Make sure the doorframes are not allowed to twist during this operation*

- j) Un-tape and check correct fit and opening and closing.

*Some adjustment by carefully bending the tubes may be required.*

*Leave the clecos in position holding the tubes to the hinge for now. They are not riveted to the hinge until the lexan is fitted.*

### 18.3.2 Upper door frames

- a) The door is hinged with two short lengths of aluminium hinge. These are attached to a 20x20mm piece of aluminium angle. This angle has its upper horizontal edge facing outwards, at the same level as the wing undersurface

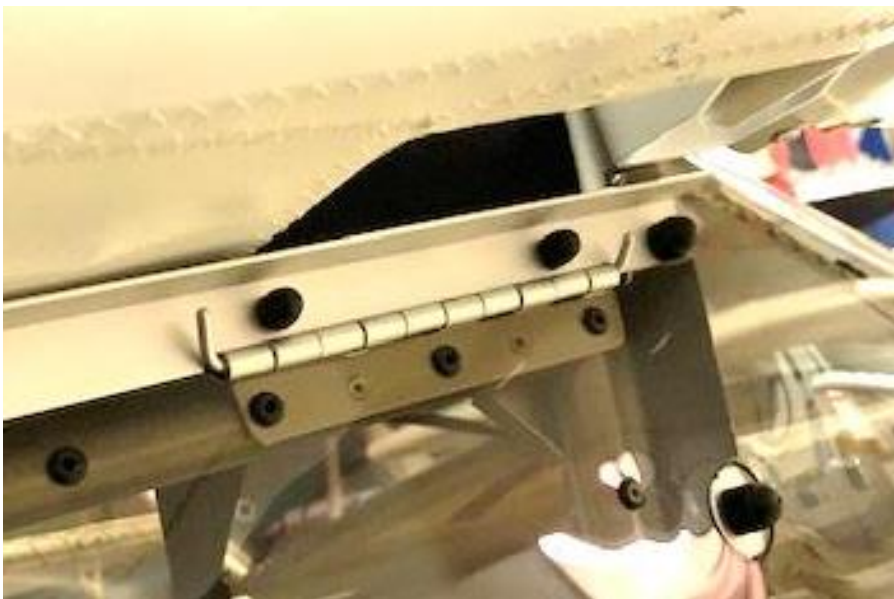
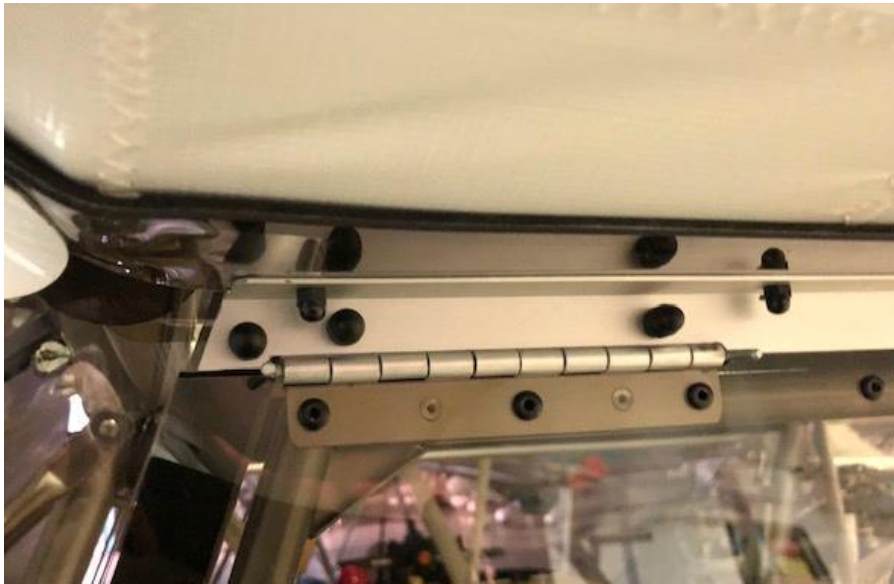


**Figure 313 upper door**

- b) Offer up the 20x20 angle and align its top edge level with the wing under surface. Mark the position of the tube centres for TU34 and TU 6, then drill the centre of the angle in these positions – 4mm diameter in TU34 and 5mm in TU6.
- c) Offer it up again, mark and drill the TU34 and TU6 to match, and temporarily fix into position and verify fit, then remove.

d) Attach the hinges.

*File / dremel cut, the angle so that the hinges can be inset, so the edge aligns with the hinge axis.*



**Figure 314 Upper door frame hinges (port front and rear).**

e) Fix the hinges to the angle. Use 4mm panhead screws – nuts to the outside.

f) Temporarily fix the assembly in position on the TU34 and TU6 tubes.

g) Offer the upper doorframe up into position.

*It should fit in the opening with even spacing – again of 10-15mm. Use some spacers to sand it off from the lower door frame and TU34 at this spacing. Adjust the bends as required to get a nice fit.*



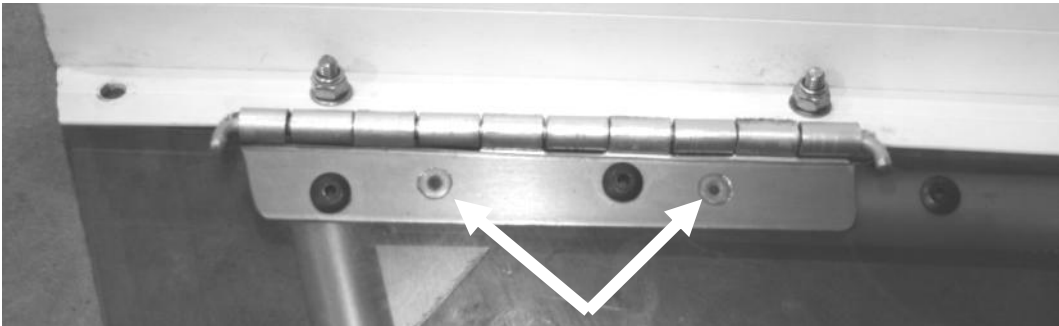
*the TU34 sits at a vertical angle different to the TU6 carefully bend the rear frame upright outwards as required to get alignment with both.*

*Trim excess off the ends of the tubes so that the ends align just below the hinge axis.*

*When happy with the fit and with the frame taped into position. Drill through the hinge and the tube ends and fix with clecos.*

- h) Cut a top rail tube to fit inside the tubes, and fix into position.

*Use 2 x 3mm countersunk rivets to fix to the hinge*



**Figure 315 top rail tube fixed to hinge**

- i) Check opening and closing of door frame and good alignment. Tweak as necessary, then rivet on the upper corners gusset plates, with 4mm aluminium rivets.



**Figure 316 upper corner gusset plates.**

### 18.3.3 Fitting the Lexan

- a) Mark out the Lexan sheets using the patterns supplied.

*The Lexan is big enough but there is not much spare space. Lay out the patterns and find the best arrangement to ensure they can all be cut from the sheet.*

*Cut out the Lexan using a pair of large tin snips.*

*The patterns are supplied as a guide and your individually constructed doors will vary slightly, so cut out oversize to be safe.*

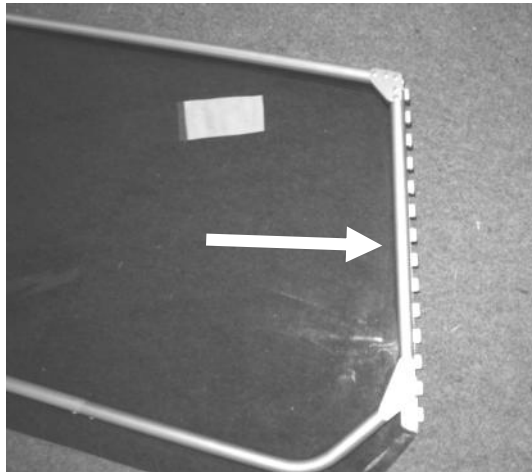
- b) Remove the doors from the aeroplane for fitting the lexan. Fit the Lexan to the lower doors first.

*Use the forward and upper edges as your accurate edges and trim so that these fit nicely. Allow a generous overlap on the lower and rear edges, which can be trimmed later.*

- c) Before riveting mark the position of the holes to be drilled on the doorframe.

*Use a nominal rivet spacing of 60mm adjusted where required to provide an even spacing on each side. Remove the protective covering from the inside face of the Lexan, leave it in place on the outside, but remove it using your fingernail around each point to clear the rivet heads.*

*The front vertical tube is riveted in position with the lexan. Drill the hinge and tube at this stage ready*



**Figure 317 front tube**

- d) Drill and rivet the Lexan into place.

*Work from the upper front corner, outwards and downwards together. When drilling angle the drill slightly away from the last rivet. When squeezing the rivets bring the rivet upright. This then applies some light tension to the Lexan and prevents the Lexan bulging between rivets.*

*Take care when drilling to ensure the tube is drilled centrally.*

- e) Repeat this process for the upper doors.

*The upper edge of the Lexan is your accurate edge and should be butted up against the edge of the angle. Cut a recess around the hinge bulge to achieve this, using a file or dremel.*

*Allow generous overlaps front and rear and with the lower door at this stage.*

- f) Refit the lower door. Using a chart pen or similar accurately mark the lexan for trimming.

*It should fit evenly just inside the joggle on the glassfibre door sill and overlap the rear window by 25mm at the rear. Dress the final edges with a sanding block to get a nice smooth rounded edge.*

*Apply 3mm self adhesive foam strip on the upper edge of the lexan aligned with the top edge, where the upper door will overlap.*



**Figure 318 lower door lexan fit**

- g) Refit the upper doors, mark and trim the lexan.



**Figure 319 upper door lexan fit**

*The rear edge of the windscreen sides should earlier have had two lines of 1x10mm self adhesive foam applied, and the rear windows forwards edge a beading strip and a line of 3x20mm self adhesive foam applied. If not do it now!*

*The lexan overlap should be cut to match the edges of this foam. In addition a small cut out area to allow the lexan to pass around the end of the rear upper fuselage longeron TU2.*

#### **18.3.4 Fittings**

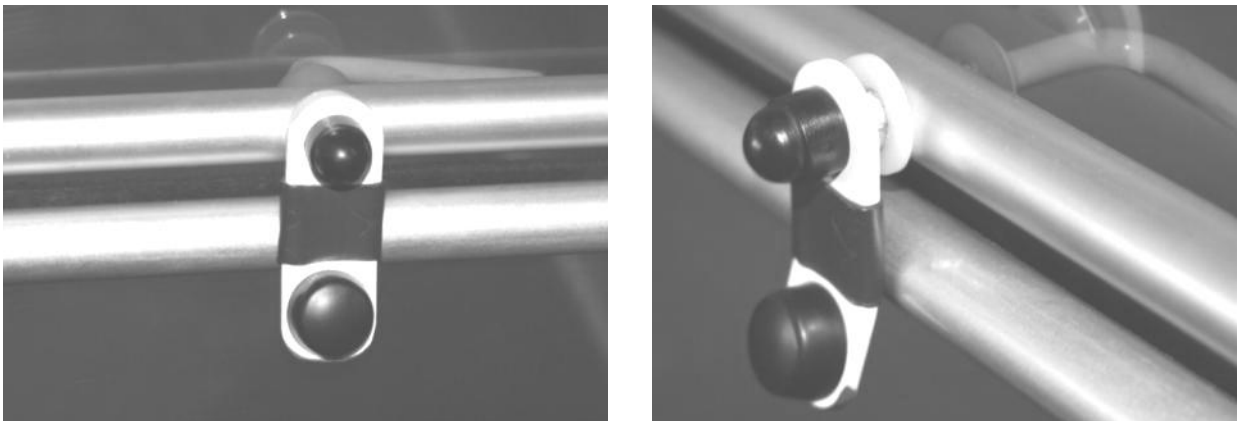
- a) Drill through the centre of the upper door frame lower tube 480mm from the forward edge of the door using a 6mm drill bit to accept the door handle.

*This measurement doesn't need to be exact, but should be even between sides. And either be through a rivet position or between two.*

- b) Use the handle / catch parts from the main kit, inserting the handle through the hole in the doorframe.
- c) On the inside fit a thin plastic washer followed by the plain nut, hooped shape handle and Nyloc nut.
- d) Tighten the nuts against one another to lock the parts into position.

*Adjust the position of the nuts so that some friction is felt when rotating the handle. The hooped handle can be left as is or the hooped part cut off to leave a flat lever as desired.*

*Some protection to stop the lever scratching the lower door tube is desirable. In Figure 303 below the lever has been fitted with some heatshrink (the black band) to achieve this.*

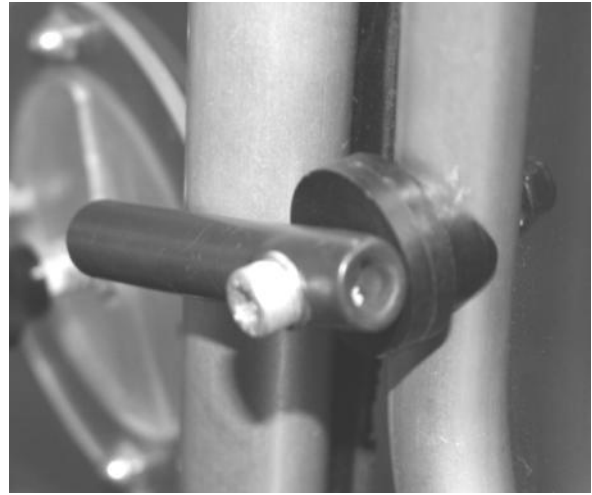


**Figure 310 upper door catch (this one has had the hooped part cut off, is bent inwards slightly and has a skiffy cap fitted to provide a handle 'knob')**

- e) Fit the forward catch by drilling a 5mm hole in the forward vertical of the upper door frame just above the bend radius (see Figure 308)

*Assemble the parts with two 3mm plastic washers, and a saddle washer between catch and doorframe.*

- f) Adjust the tension to achieve some friction.



**Figure 311 upper door forward catch.**

**g) Fit the door catches.**

*Offer up the catch and aluminium angle. Determine the best position to fix the angle to the door pillar, so it lies flat against the gusset plate on the door, and doesn't cross any rivet heads. Drill and rivet it in position. Use two 4mm steel rivets and snug down firmly, so that it fits tightly with no movement.*

*Determine the best position for the latch, ensuring maximum engagement when closed. Mark the position and drill and rivet in position. Note that two 4mm washers must go between the latch and gusset plate under each hole to raise the latch enough to slide over the angle.*

*The door catch is activated by pulling the wire. Fix the front end with a 4mm rivet to the underside of the door tube leaving a slight bow.*



**Figure 312 door catch**

- h) Fit the open door keeper.

*This should be positioned so that the door handle can be rotated into it. It is fitted to the wing surface with two screws (cut these to length) with spreader plates made from two rectangles of scrap Lexan 30mm X 150 (15mm radius at each end) either side of the wing fabric. This job will require two people or very long bendy arms!*



**Figure 313 door open keeper.**

- i) Now check final fit of the lower door when closed and latched, then fit the front gusset plates.

*We didnt fit these parts earlier becuae it is difficult to gurantee a nice fit between the lexan and the glassfibre at the bottom.*

*Verify the fit – it may be that the door needs twisting a little to get an even fit, but will spring back when you release it. Hold it in position and drill for the gusset plates. Still holding it in position and slightly overbent, apply the rivets.*

*This will then make the door far more torsionally rigid.*



**Figure 314 upper and lower gusset plates (port side lower door)**

## 19 Tail surfaces again

Refit the tail surfaces, and reconnect the control cables.

### 19.1 Trimmer system

#### 19.1.1 Trimmer cable

- a) Pass the trimmer cable out through the hole in the fairing at the starboard tailplane forward attachment and feed down the fuselage



Figure 315 trim tab cable.

- b) Fit the trim tab cable bracket on the bolt at the front of the flap lever guide in the position as shown below:

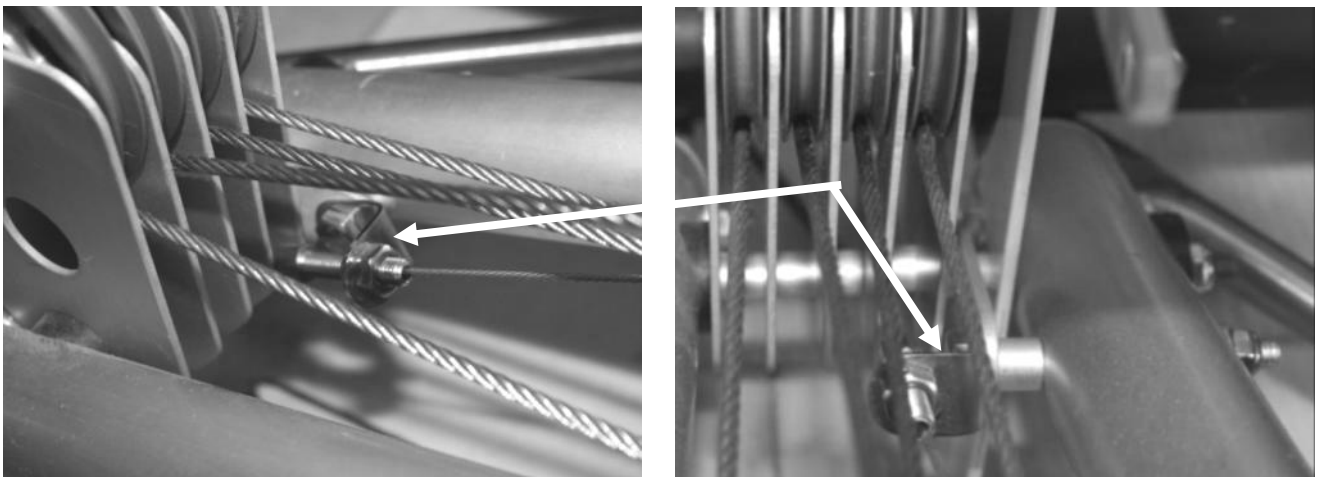


Figure 316 trim tab forward cable bracket

- c) Fit the outer cable in the sockets on the forward and rear cable brackets, and then periodically cable tie along its length to bits of fuselage structure / bracing wires so it won't rattle about.
- d) To hold the cable end into its thimble on the rear cable bracket on the elevator leading edge, cover the cable end and the thimble with a piece of heat shrink tubing over each cable/thimble combination.

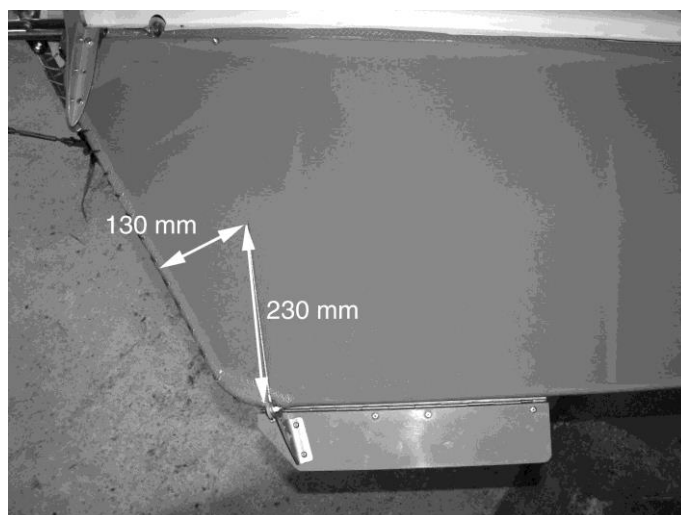
*Take care not to melt the coverings! Direct the heat away from them, and check they don't get hot.*



**Figure 317 aft end of trimmer cable.**

- e) Melt a hole in the upper surface of the elevator fabric for the inner cable, 230mm forwards of the trailing edge and 130mm away from the tapered edge of the elevator, both distances measured at 90° to the respective edge, Figure 278.

*A small tipped soldering iron is good for this job – push it in at a slight angle aiming for a hole about 4mm wide and just a little longer.*

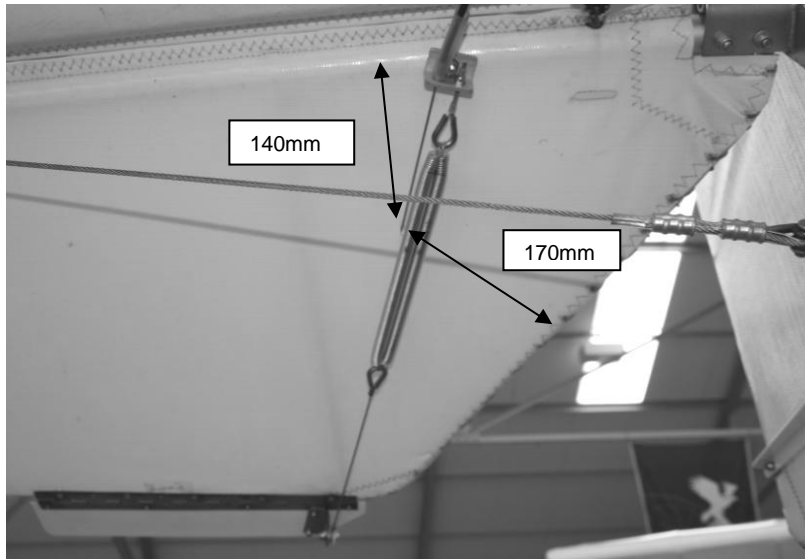


**Figure 318 position of hole in top elevator surface.**

- f) Also melt a hole in the lower surface of the elevator fabric for the inner cable, 140mm rearwards of the centre of the leading edge and 170mm away from



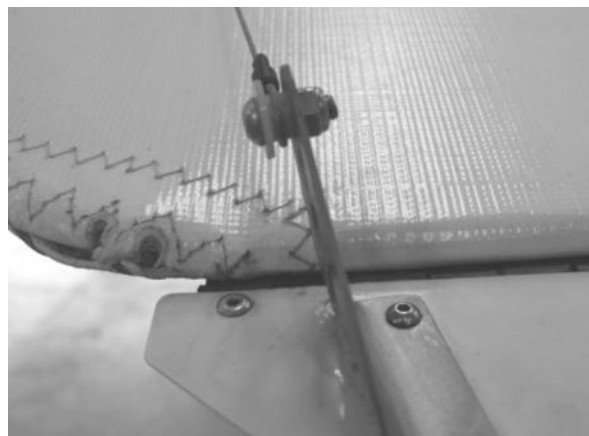
the tapered edge of the elevator, both distances measured at 90° to the respective edge.



**Figure 319 position of hole in lower elevator surface.**

- g) Thread the inner trim cable through the holes in the fabric and into the outer cable and push it steadily all the way through
- h) Attach the loop at the end of the trimmer cable to the top trim tab control horn with a bolt and plastic 'top hat' spacer.

*The cable goes on the inboard side of the horn.*



**Figure 320 cable attachment on trim tab horn.**

- i) Attach the short cable to the lower trim tab horn. It should be orientated so that the forward end has the reinforcing thimble eye in the loop. Attach **two springs in parallel** from this to the thimble eye emanating from the cable bracket on the lower side of the elevator leading edge (shown in fig 312)

### 19.1.2 Trim lever

- a) Take one of the white levers from the kit. Bend it straight. Drill as shown below:

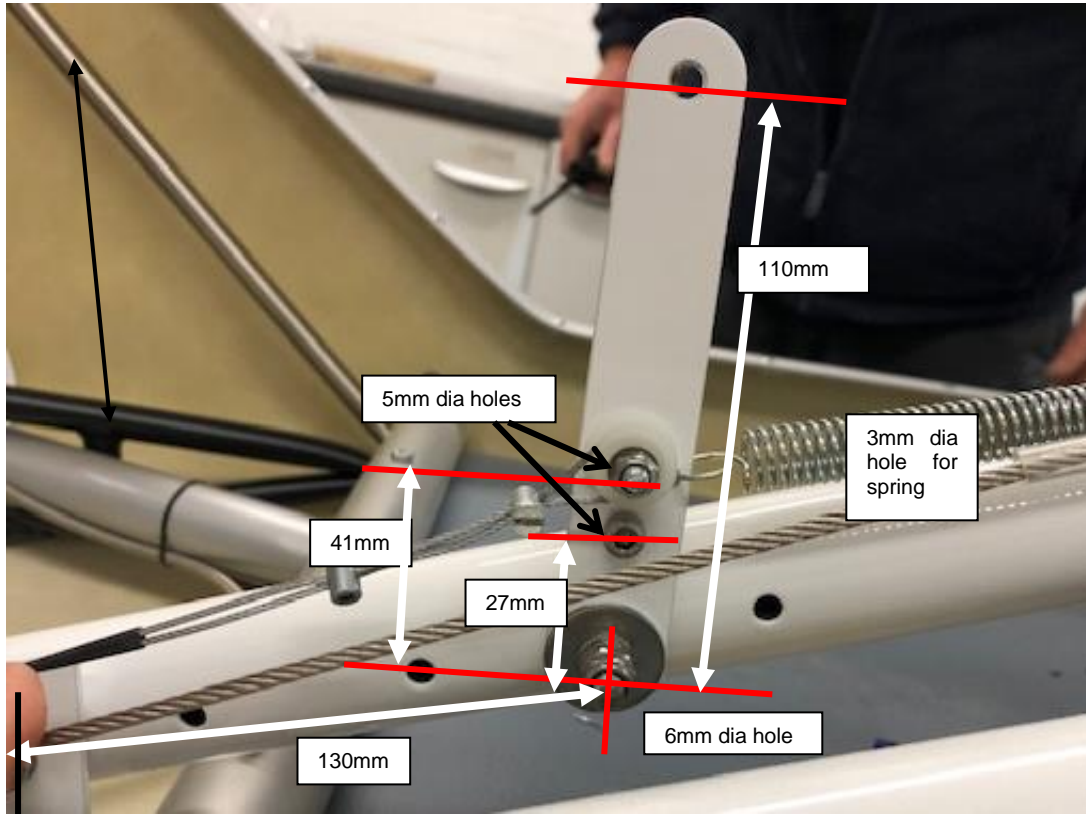


Figure 321 trim lever

- b) Drill a 6mm hole in the port TU19 for the trim lever 130mm forward from the hole centre of the central brace angle as shown above . Then fit the lever.

*There should be a saddle washer and thin plastic washer between the lever and the TU19, and on the other side of the lever a 1mm plastic washer and 6-25 penny washer. Lever can be cut and trimmed so it does not project below these washers.*

- c) Adjust the trim lever friction with the first nut, and lock it with the second nut.

*Movement should be smooth, but tight enough to prevent the lever slipping due to the trim tab loads. This can be checked on flight test.*

- d) Fit the S73 spring.

*It attaches through the 3mm hole in the lever , and fits on the side of the bracket that holds the control stick pivot bearing, using a 6mm bolt and nut and 'top hat' bush – as shown in Figure 314 below.*

- e) Fit the stop bolt

*This is an M5-30 bolt, the threaded end of which sticks out and is covered by a length of tygon tube (and covered with some heatshrink in photos below). It touches the TU19 at limits of movement and forms a control stop.*



**Figure 322 spring fitting and control stop**

- f) Attach the inner cable to the lever

*Use the M5x20mm bolt and top hat bush and washer. The cable wraps around the top hat bush and is secured using two solderless nipples. The holes in these need to be drilled out to 3mm to accommodate two lengths of the inner cable passing through.*



**Figure 323 cable connection**

- g) Adjust the neutral position to give the correct movement.

*With the trimmer lever at 90° to the TU19 tube upon which it is mounted, the tab should be level with the lower surface of the elevator.*

*Coarse adjustment can be made by feeding the inner cable through the solderless nipples, and fine adjustment by winding the adjuster on the forward outer cable bracket.*

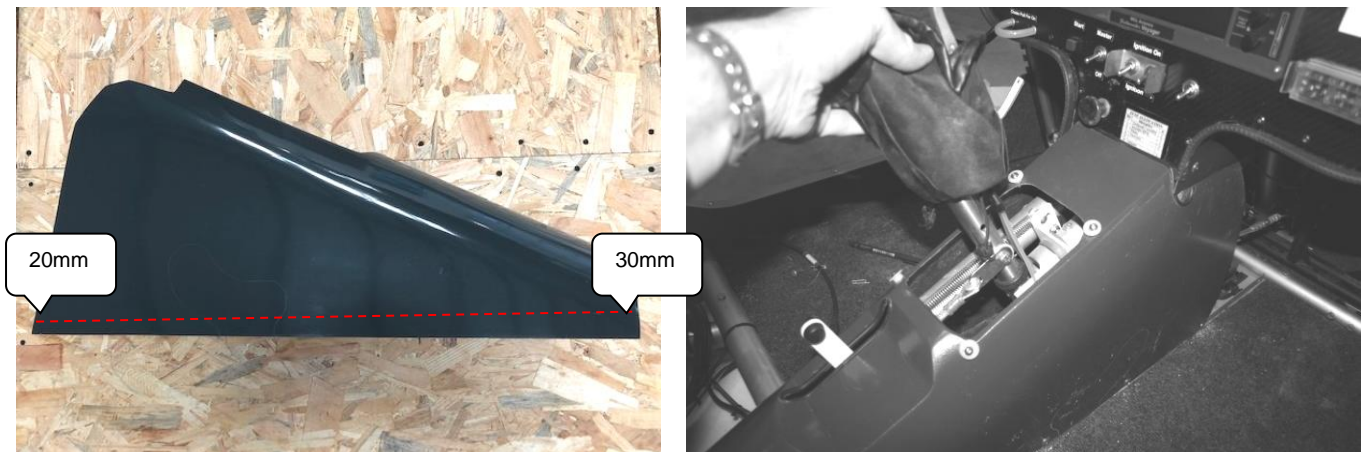
***Ensure that the trimmer works in the correct sense! Trim lever forwards, trim tab deflects upwards, pushes elevator downwards, tail goes up, nose goes down.***

## 20 Centre console.



**Figure 324 console overview**

- a) If fitted, remove the instrument panel surround fairings. Undo the instrument panel and lift it up out of the way for initial console fitting. The console as supplied is a little deep. Trim the lower edges – 20mm at front edge to 30mm at rear
- b) If using the centre stick, cut an opening in the centre console around the stick position, small at first and open up later



**Figure 325 cutting lower edges and stick opening**

- c) Put it loosely in position and mark and cut a preliminary slot for the trim lever (30mm from centreline of console) – or alternatively undo the lever and lay it out of the way and make the slot later.

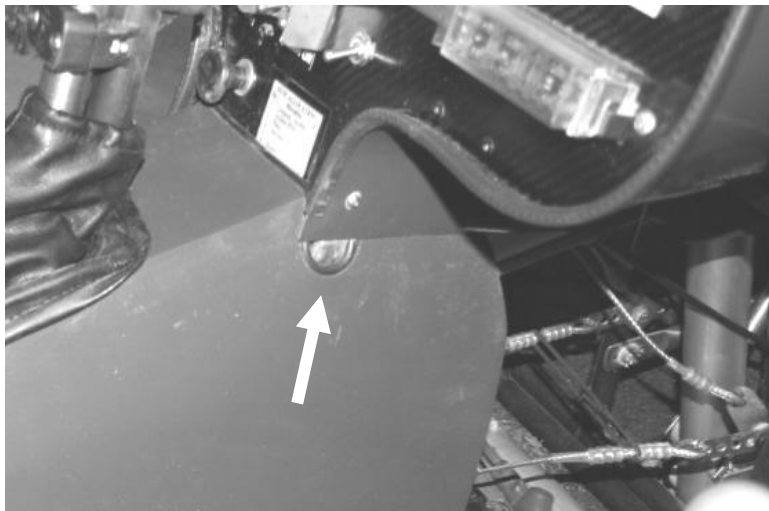
d) Trim to fit

*Cutmarks are provided to indicate where to cut to fit over the TU15. The marks in the side of the fairing are where to trim for the dual stick option.*



**Figure 326 console trimming**

*It will also need trimming around the front upper corners as shown below.*

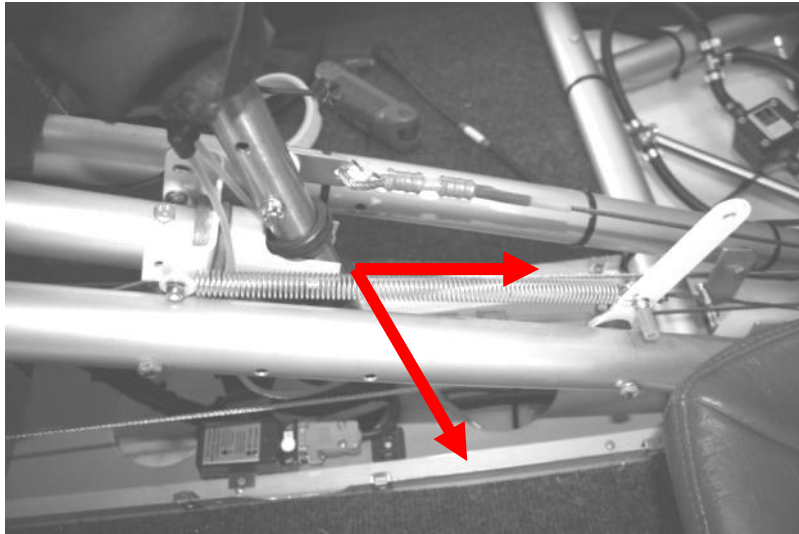


**Figure 327 front corner trimming**

e) Use thin Aluminium angle fixed to the floor with self tapping screws, to mount the lower edge of the centre console.

*The angles should be 150mm apart*

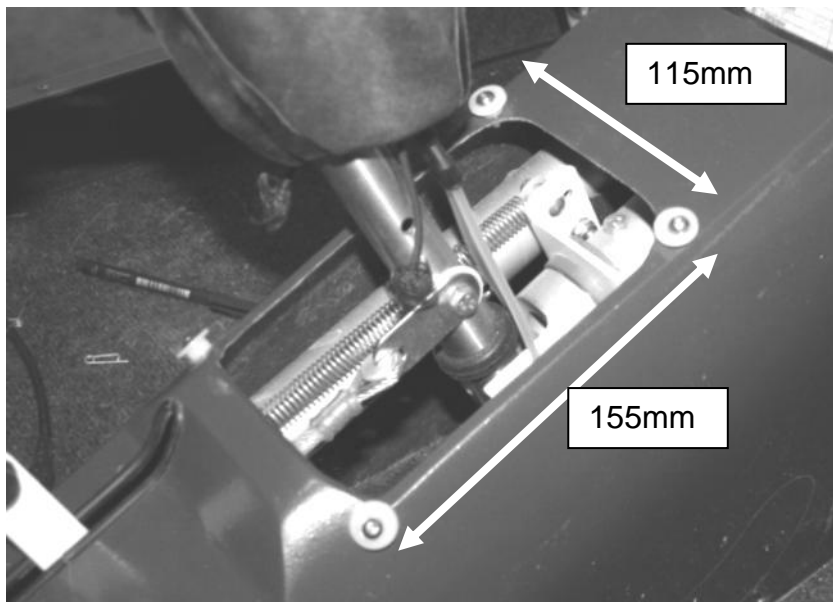
The console should fix to the angle with screws each side – use the 4mm captive lugnut clips and self tapping screws.



**Figure 328 lower fixing angles**

- f) Confirm full and free movement of the stick and open up the hole as required for clearance

*Drill and fix the top hat bushes that form the retaining points for the controls stick gaiter using the dimensions shown below.. These fit with 4x16mm stainless screws, nuts and washers.*



**Figure 329 Control stick gaiter fixings.**

- g) Carefully trim the slot for the trim lever to allow full movement corresponding with trim tab max deflection angles

*Edge the hole with the rubber beading strip – applied with a dabs of superglue. When console is finally fixed the top of the trim lever can be fitted with a knob made from a skiffy cap fitted each side.*



**Figure 330 trim lever finished and edged slot.**

- h) The front edge of the console where it butts against the instrument panel can also be edged with the rubber beading.

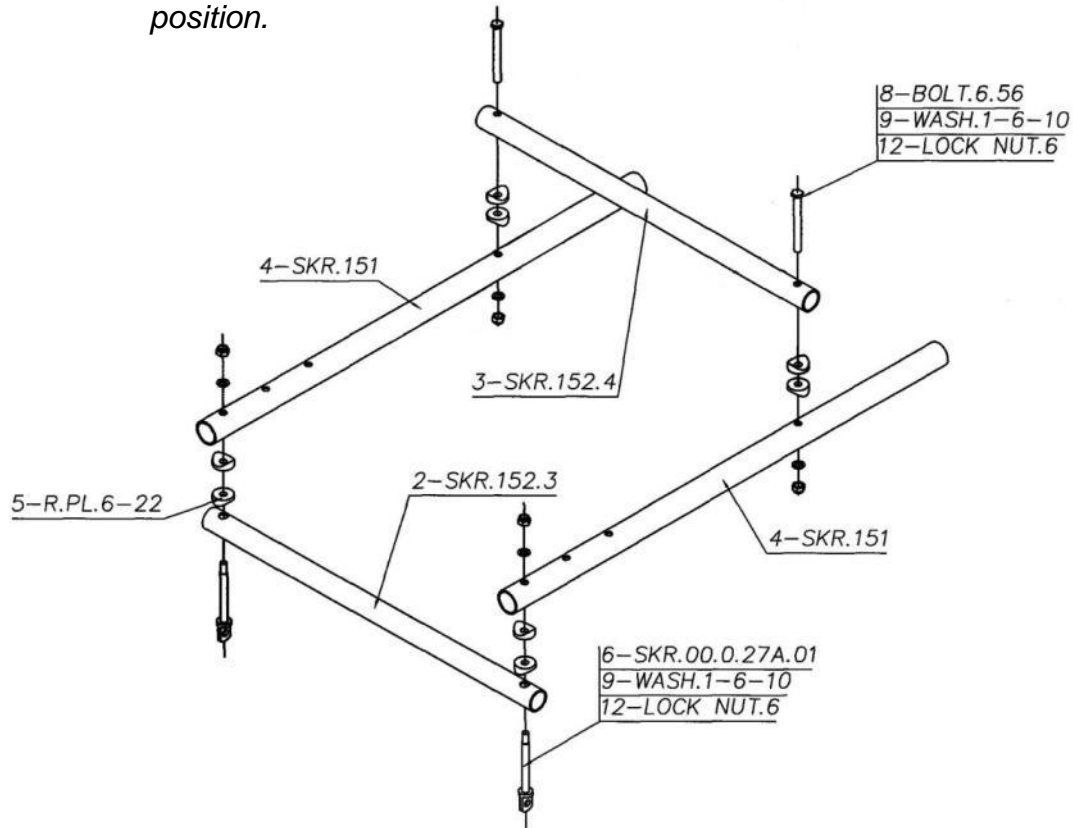


## 21 Seats and Seatbelts

### 21.1 Seats

- a) Assemble the frame as per the drawing

*Note the choice of holes in the front of the side tubes, to set the seat position.*

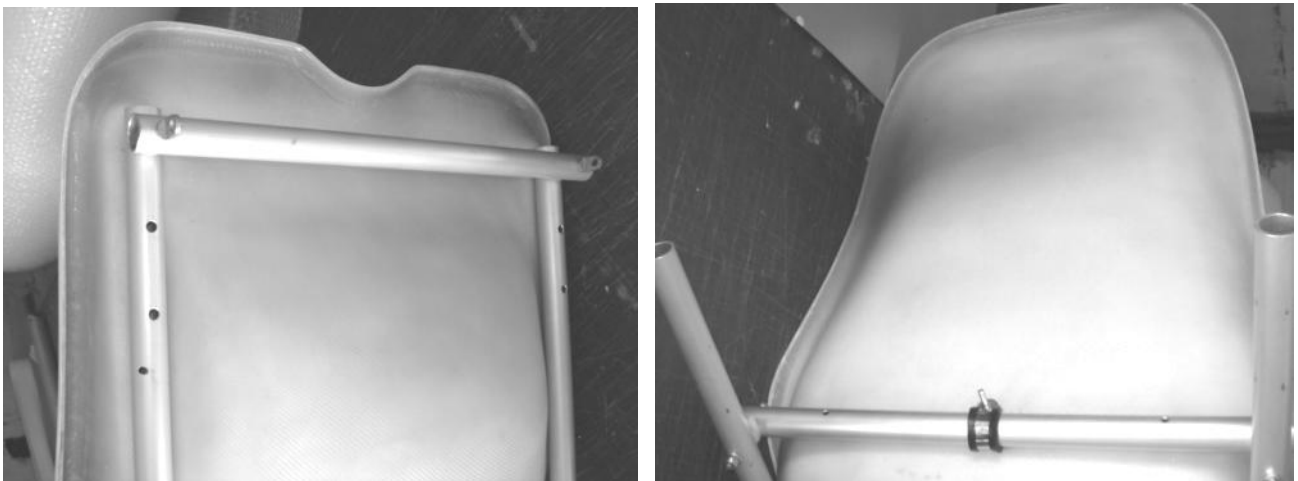


**Figure 331 seat base**

- b) Rest the glassfibre part of the seats on the base and drill and fix them.

*Front is fixed passing the SKR 0.27 eyebolt through the seat base.*

*At the rear the seat is fixed with a P clip, and 5mm panhead bolt*



**Figure 331 Front and rear fixings**

- c) Trim the front inside edge as shown below to facilitate clearance from the centre console.



**Figure 332 inside front corner trimming.**

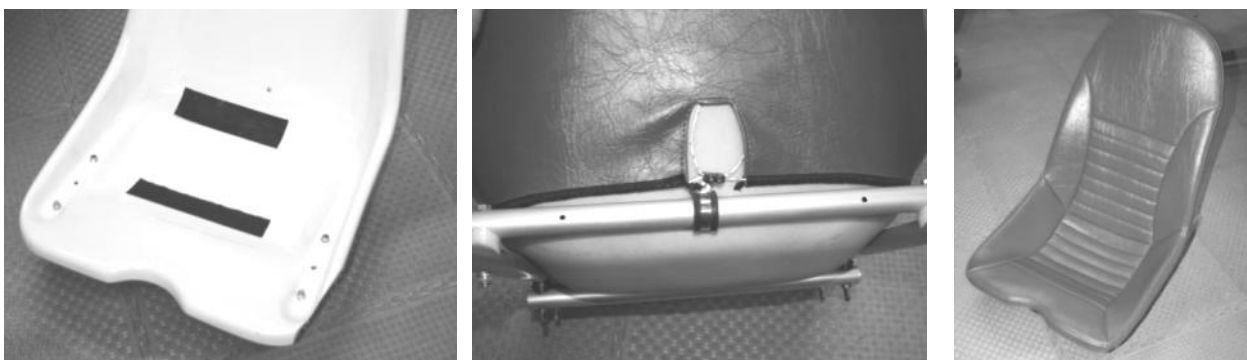
- d) If quick adjustment between length positions is required a second front crossmember may be fitted as shown below



**Figure 333 optional second cross member**

- e) Attach the two strips of Velcro to match the Velcro in the inside of the seat covers, and then put on the seat covers.

*The covers have a cord running around a pocket in their perimeter. Make sure this is slack and then tighten after fitting. Push the east cover down into the seat pan to fully engage with the Velcro strips.*

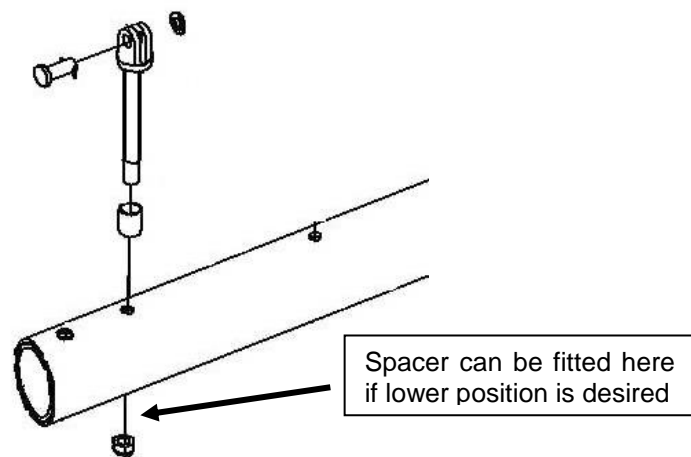


**Figure 334 seat cover fitting**

f) The Nynja seats have two height positions.

*Seats attach onto the female eyebolts on TU15. The Nynja has long eyebolts with small spacer sleeves. These spacers can be fitted above the TU15 – in which case they lift the front of the seat, or can be fitted under the TU15 if a lower position is desired.*

*At the rear the inboard rest peg on the TU27 has two positions. The outer rest is an L bracket. It attaches directly for the higher position or must have a 20mm trimmed off for the lower position.*



**Figure 335 Front fixing**



**Figure 336 rear seat rest positions**

## 21.2 Seatbelts

- a) The seatbelts have their shoulder straps looped over the upper rear cabin cross-piece.



**Figure 337** shoulder strap looped over frame.

- b) The lap strap part of the seatbelts should be looped around the main undercarriage cross-beam.

*Take a double wrap around the beam to prevent the strap slipping under side-loads.*



**Figure 338** lap strap looped around undercarriage beam.

- c) The seatbelt should be brought around the sides of the seat.

*Belts have a single adjusters for lap and shoulder harnesses. Make sure belts are free running and can centre. Don't be tempted to secure to the beams.*

## 22 Fitting the teardrop wheel spat option.

### *Nose Wheel*

Check that the axle is correctly positioned behind the forks. The nose wheel leg will need drilling at the position shown below for the wheel spat attachments. Either use a 5mm rivut as shown, or drill and tap to an M5 thread

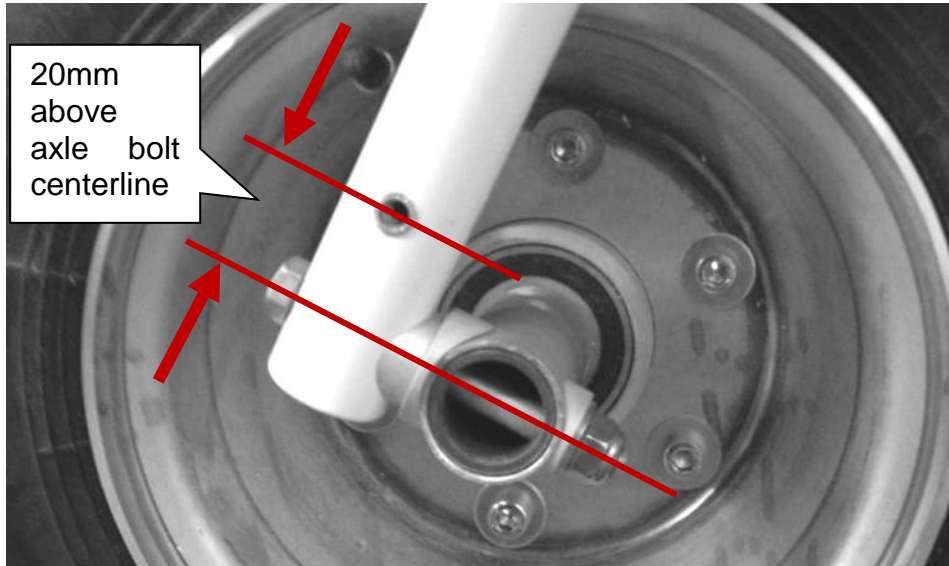


Figure 339

The spat should be offered up to the nose-wheel, to mark the position of the hole for the nose-leg, if not already marked and/or cut-out.

As a guide the holes should follow the following measurements – all using a flexible measuring tape laid to follow curve – us a dress making tape or pre marked strips of masking tape:

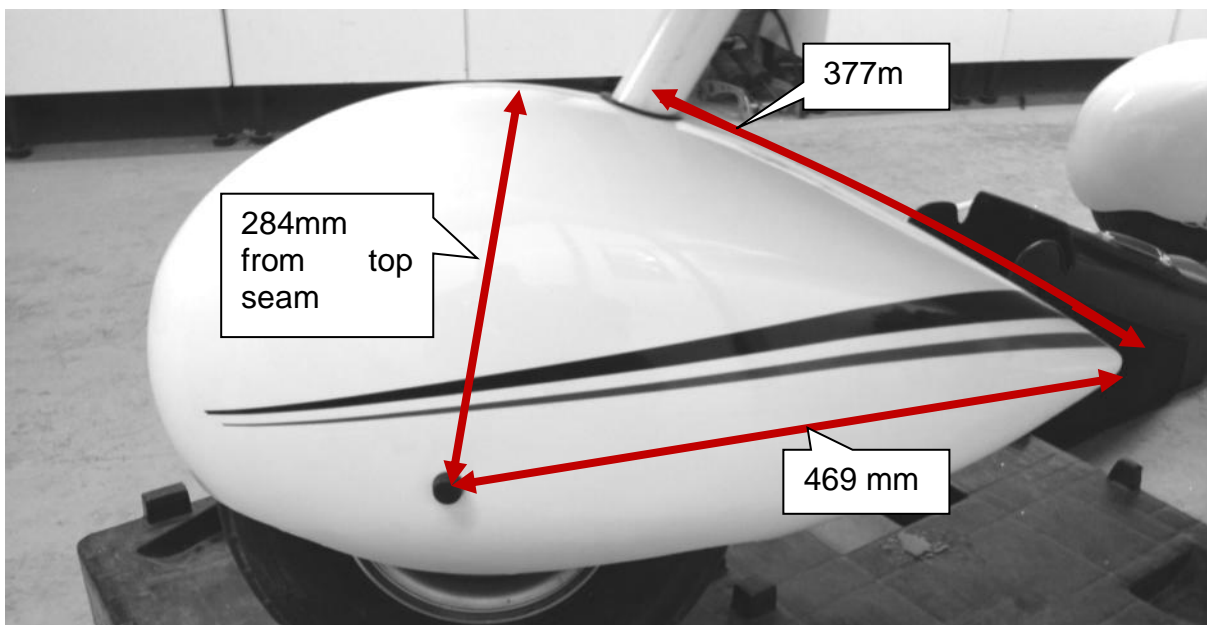


Figure 340

The top hole for the nose leg to pass through should be 40mm, and then enlarged a little to produce a slight front to back oval so the nose leg can pass through at the required angle. Use the rubber beading that is supplied in the kit to edge the hole. For it to fit the glassfibre may have to be sanded a little thinner around the hole edge. Aim for the completed and edged hole to be a slop free fit over the nose leg.

Drill the attachment holes 5mm diameter. The spat attaches using 2 x M5x50 bolts and 30mm spacer between fork and spat sides. Under the head of the bolt should be – M5washer, skiffy cap base, 1.5mm plastic washer.



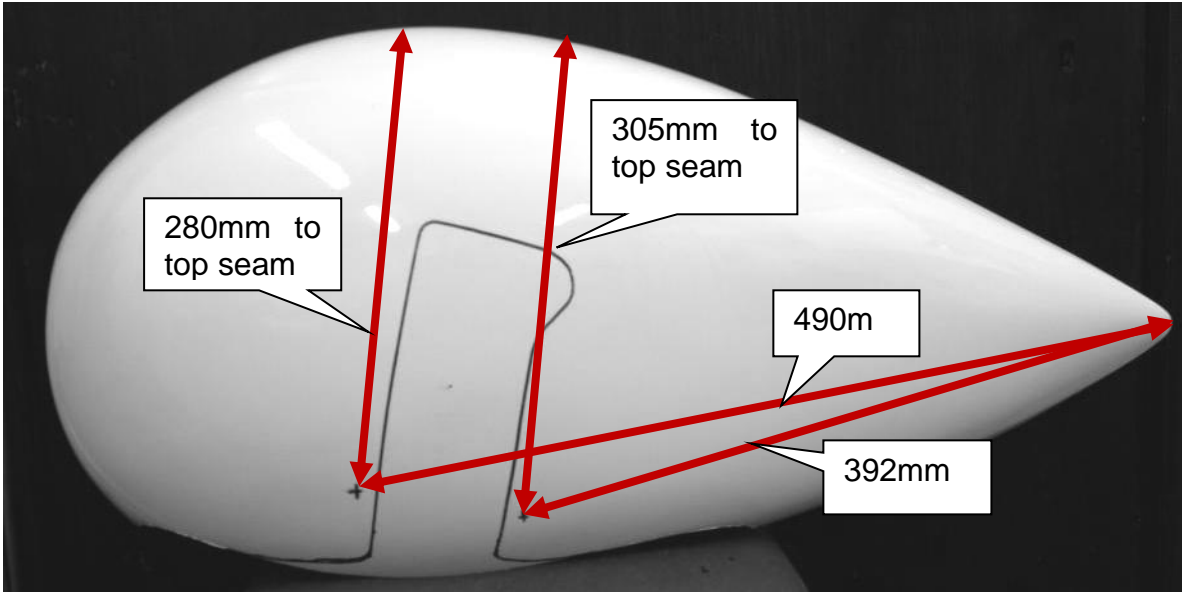
**.Figure 341**

*The nose-leg will have to be dropped out of the aircraft to fit the nose-wheel spat. Undo the bolt securing the nose-leg at the top of the leg, and the bolt securing the steering bar to the nose-leg. Have someone hold the tail of the aircraft down whilst you slide the nose-leg out.*

*The spat was not fitted earlier to protect it from all the parts which you dropped whilst fitting the engine!*

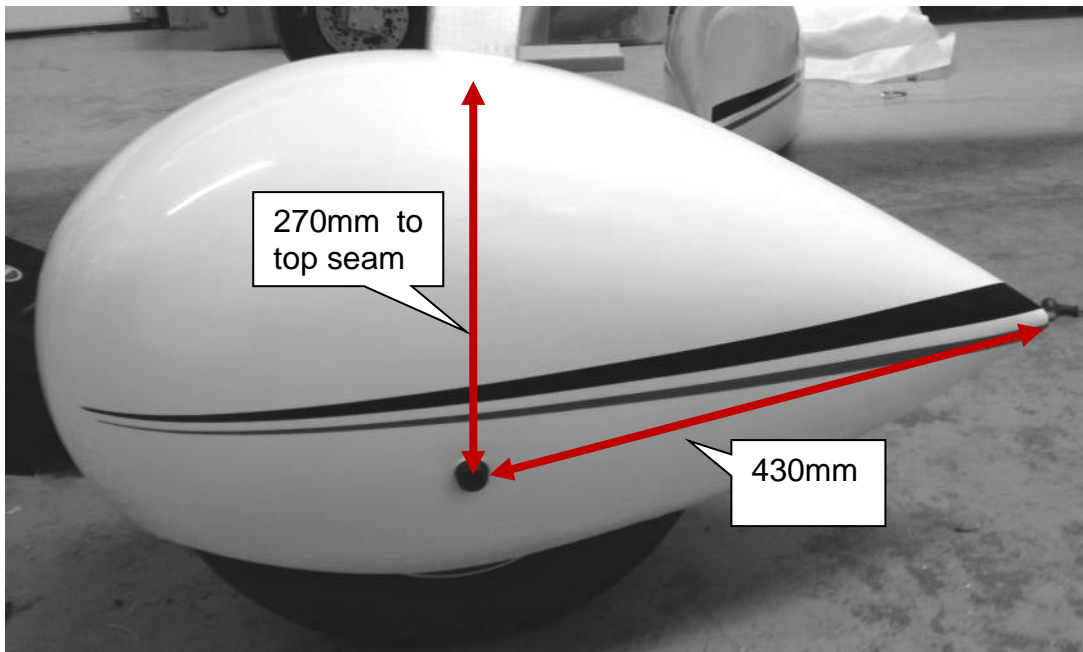
### ***Main Wheel spats***

Refer to template – fig 345. The template references on the inner attachment screw holes. Position of these holes is shown below (all dimensions around curve as previously):



**Figure 342**

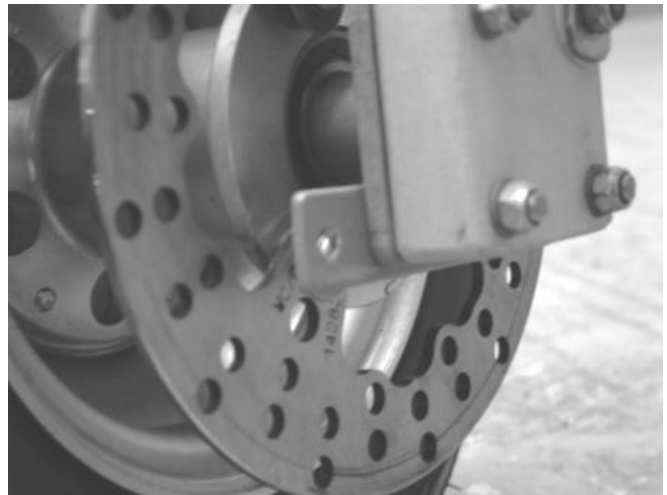
Cut out using a dremel or similar, sand finished edges smooth. Note that spat fits over brake calliper. The outer attachment hole position is as shown below. Drill all attachment holes 6mm diameter.



**Figure 343**

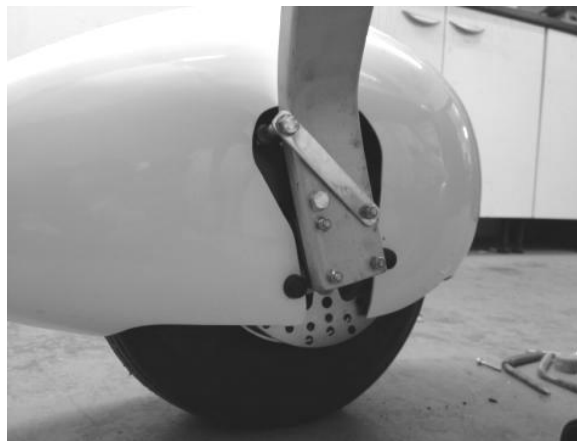
*The inner attachment bracket should have been fitted earlier – as was detailed in the main build manual. If retrofitting spats fit them now. Use the new slightly longer M6 bolts supplied.*

*The outer attachment bracket fits on top of the axle and is held by the wheel retaining bolt – the bolt should pass through the second hole in the bracket – fig 337*



**Figure 344**

The main wheel spats attach with 2 x M6x20 screws to the inner attachment bracket, under the screw head should be a skiffy cap base and 1.5mm plastic washer.



**Figure 345**

The outer attachment bolt is an M6x50 and a 20mm plastic spacer bobbin. Under the head of the bolt should be – M6 washer, 1.5mm plastic washer.



**Figure 346**

The spats as supplied have generic openings for the wheels. It will be necessary to trim in places to give adequate clearance from the tyre. Aim for a minimum 10mm gap between tyre and spats.



Some final sanding and fettling may be necessary on the gear leg cut out section and inner attachment holes to get angles aligned between left and right spats, and to avoid abrasion on the gear legs and the brake lines.

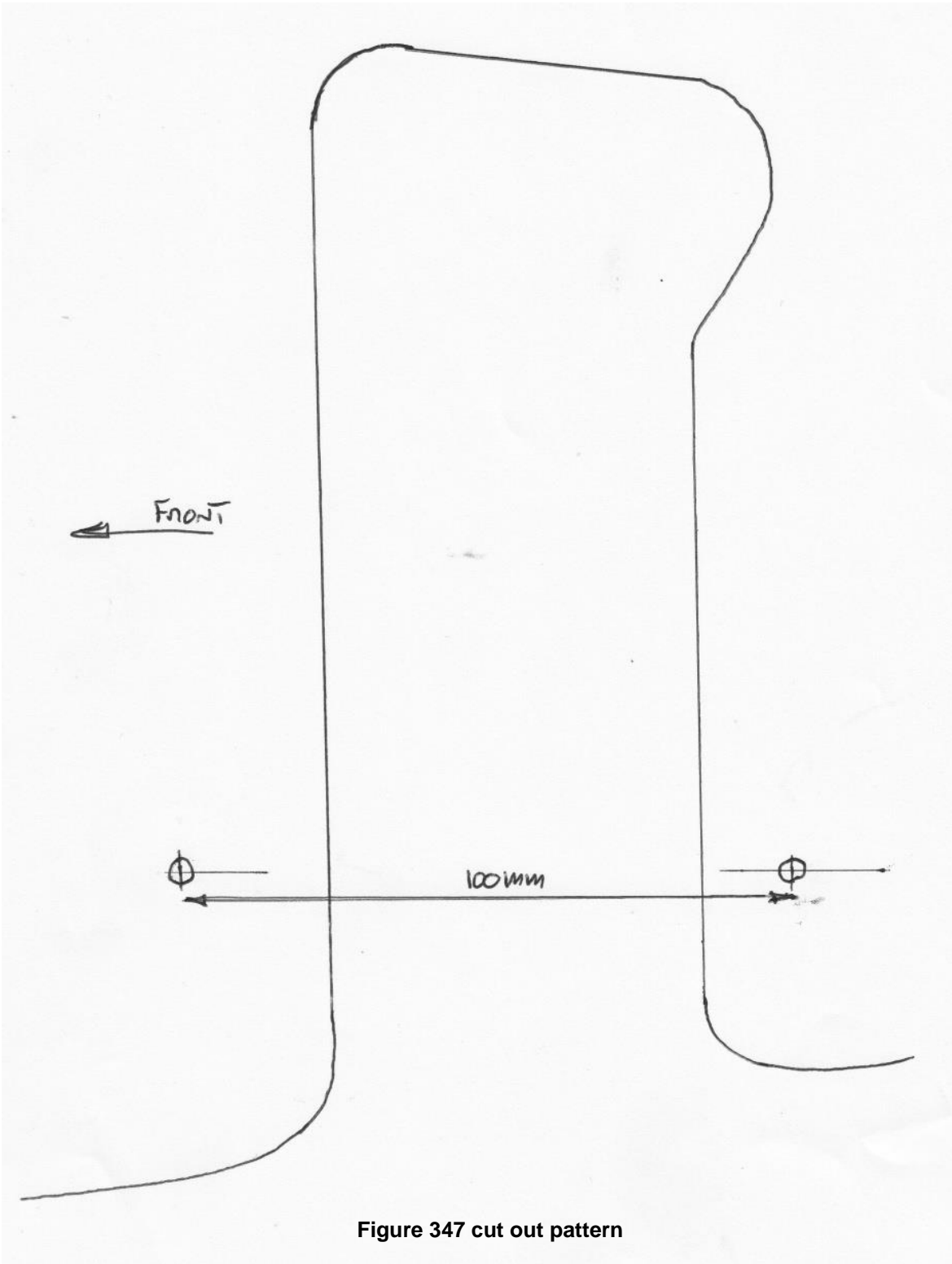


Figure 347 cut out pattern

## 23 Fairings

All fairings are supplied as trimmed from the mould and will require edges sanding smooth and even.

### 23.1 Lower Fin Fairing



Figure 348 lower fin fairing

- a) Sand the inside of the fairing at the rear where it slips over the fin leading edge tube.

*This will help ensure a smooth non abrasive surface where the two meet. Additionally apply some clear protective tape over the fin in the contact area.*

- b) Secure the fairing to the fuselage using aluminium white 4mm rivets.
- c) The edges can be taped over with white self adhesive vinyl tape if desired.

### 23.2 Upper Fin Fairing

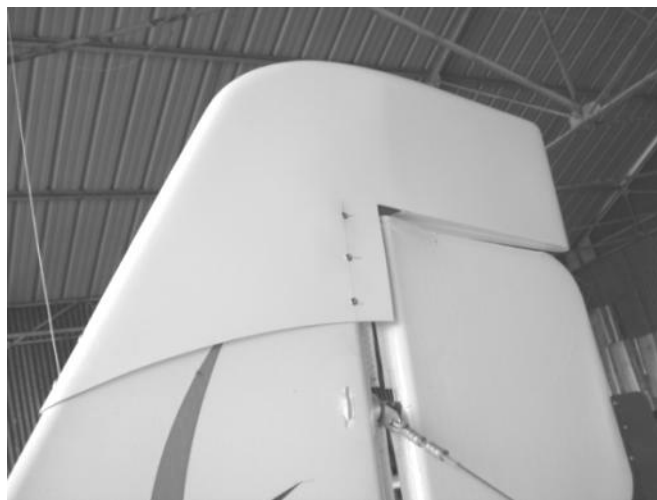


Figure 349 Upper fin fairing

- a) Sand the inside of the fairing at the rear where it slips over the fin leading edge tube, and the trailing edge tube.

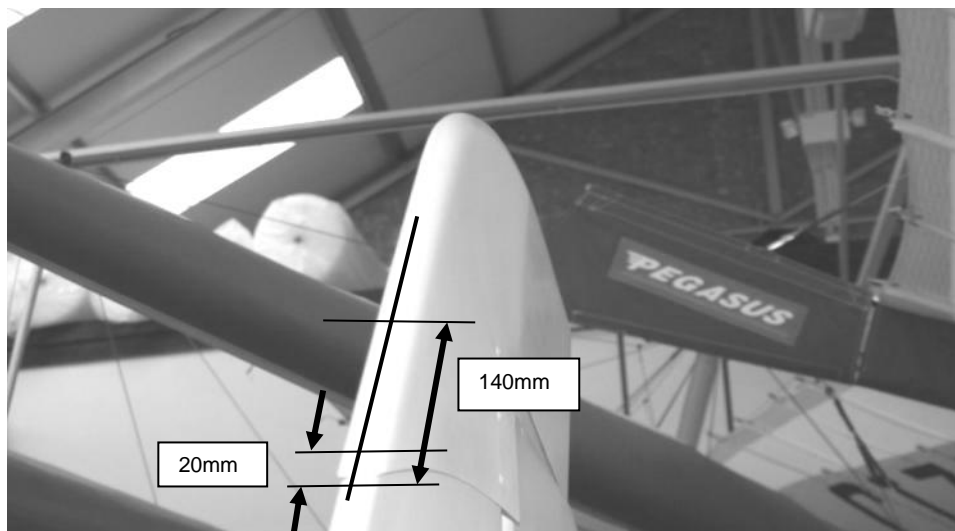
*This will help ensure a smooth non abrasive surface where the two meet.*

- b) Ensure a good straight fit, and drill and fix using 4mm aluminium white rivets.

*Use clecos / skinpins before rivetting*

*The leading edge should be secured with two rivets on the fin leading edge centreline – one 20mm from the lower edge of the fairing and the other 140mm. Make the holes in the glassfibre slightly oversize to avoid splitting the gel seam when the rivets are pulled. If this does happen its only cosmetic (glassfibre is laid up over the join inside during construction ) And can be finished with a self adhesive pinstripe.*

*Use 3 rivets on each side through the rear spar – taking care to position the top rivet hole below the existing rivet under the covering at the top of the tube.*



**Figure 350 rivet position**

### 23.3 Wing Root Fairings



Figure 351 wing root fairings

Use the 4x10mm white plastic pan head screws to secure these.

*7 screws evenly spaced should be sufficient. Make sure the outermost on the top is not drilled too close to the wing root batten where the nut might foul it.*

*For best effect against the tinted screen viewed from the inside, we painted the inside of the fairings black, and use the black domed headed nuts*

### 23.4 Cable Exit Fairings



Figure 352 Cable exit fairings

Make sure cable exit holes are generous, then fix fairings with the white 4x10mm plastic panhead screws.

## 23.5 Tailplane Leading Edge Fairings



Figure 353 Tailplane leading edge fairings

These can be fixed using three white aluminium 4mm rivets.

*Take care not to drill the fuselage tube when drilling for the upper one! – and keep it as low as possible.*

*Alternatively they can be fixed with a single plastic panhead screw at the front and taped on their edges to hold at rear.*

*In position they hide the tailplane front mounting bolt. It is a good idea to cut a hole on the underside of the fairing so that the nut can be inspected on preflight and periodic inspections.*

## 23.6 Wingstrut end Fairings (Socks)

These are simple reinforced fabric fairings that velcro into position on the outer strut ends as shown below. Strips of velco are then stuck on the wing covering to secure the outer ends.



Figure 354 strut end fairings

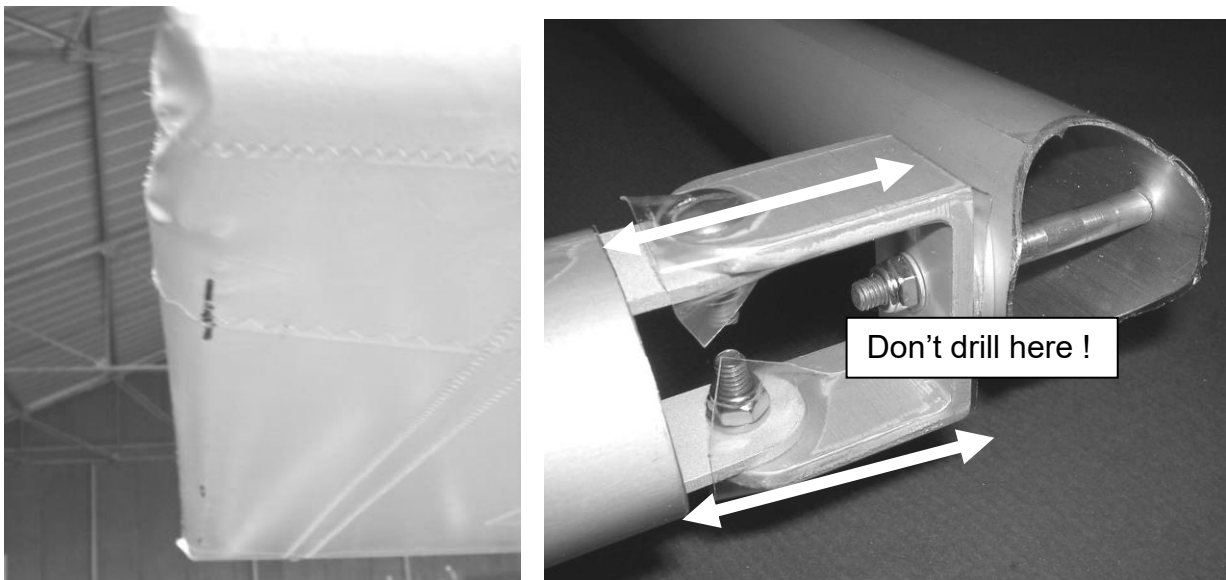
## 23.7 Wingtip Fairings



**Figure 355 wingtip fairings**

a) These attach with 5 rivets on the top and 5 below.

*Use the white 4mm aluminium rivets. These should fix the wingtip fairing to the TU37a tip tube. Take care not to drill through the U brackets at the ends of the tubes.*



**Figure 356 Wing tip**

b) Drill the wingtip fairing 35mm from its edge.

*After verifying where to drill, and checking clearance from aileron, drill the wingtip fairing first. Then offer it up and drill through the holes into the tip tube.*



**Figure 357 marking, drilling and fixing the wingtip fairings.**

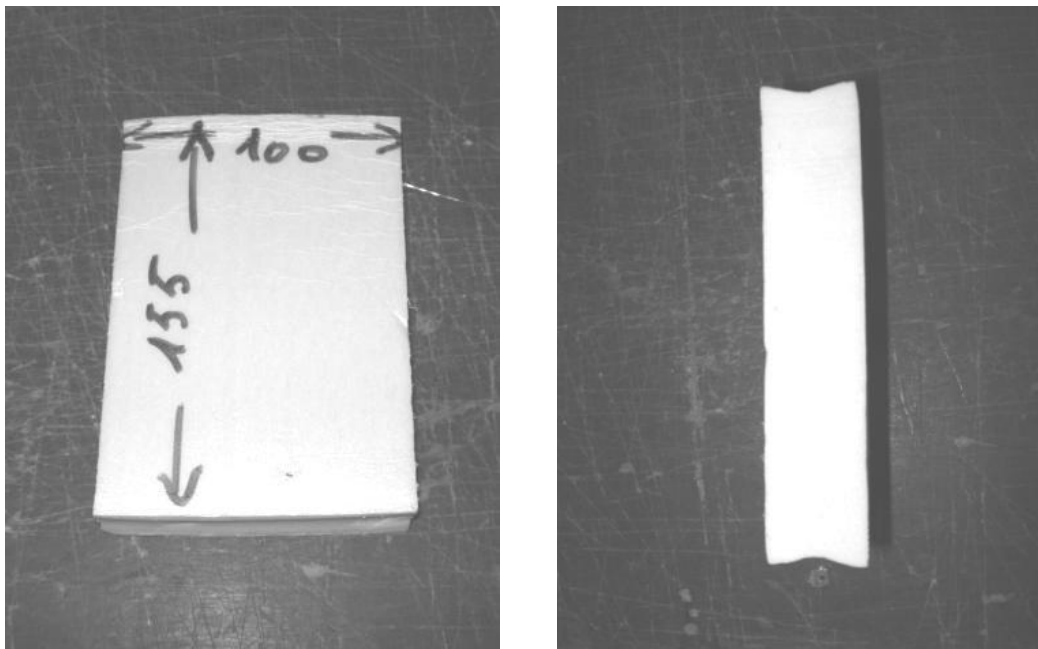
## 24 Aerofoil Profile Support Blocks

These fit inside the wing between each top and undersurface batten and maintain the wings profile at speed.



**Figure 358 wing profile support blocks**

- a) Cut the 10mm wide foam strip supplied into 155mm lengths. Cut 2 for the very end battens 110mm.
- b) Using some 80 grit sandpaper wrapped around a batten sized tube, sand in some grooves on the edges Figure 357 below



**Figure 359 Support block dimensions and grooves**



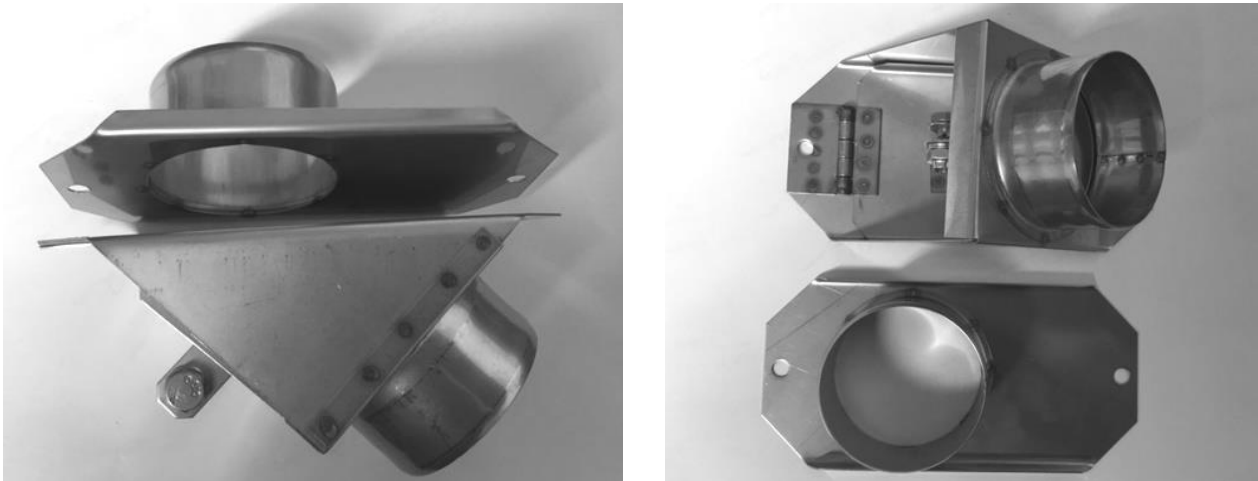
- c) Working from tip to root, and through the zips in the wing covering underside, insert the blocks into position.

*The best technique appears to be to slot against the lower batten first and push , then push the block downwards and under the upper batten into place.*

*Slide the block so as its centre is around 350mm behind the rear face of the leading edge.*

## 25 Fitting the heater option

The heater control valve consists of a flap in an open ended box fitted to the engine side of the firewall, and a flange on the cockpit side of the firewall, that diverts warm air from the exhaust heater jacket into the cockpit. On the cockpit side a length of scat hose takes the warm air to a diffuser T.

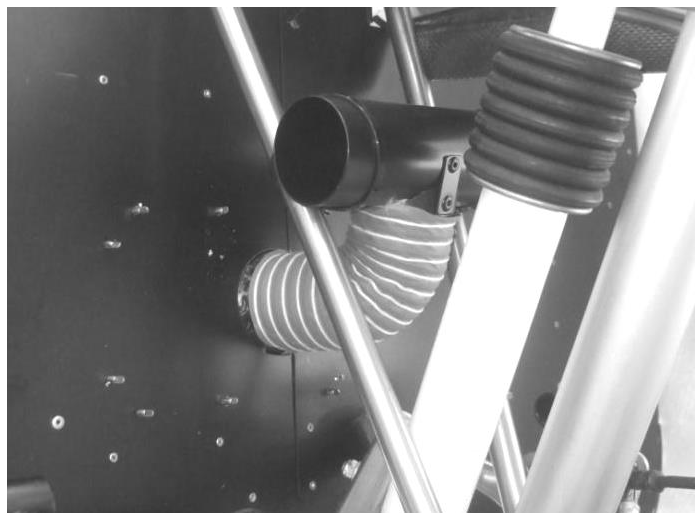


**Figure 360 Heater control valve.**

- a) Cut a 50mm diameter hole in the firewall to accept the heater control valve.

*This hole should be positioned at or close to the centre of the firewall and so box sits just above the stiffening angle*

- b) Fix the valve to the firewall using 5mm panhead bolts and nyloc nuts orinetae the heater box to be horizontal.



**Figure361 cockpit side**

- c) Put scat hose in place between the valve and the exhaust heater jacket outlet. And between valve outlet and diffuser T.

*Just slide it into position, no hose clips are necessary on the scat hose. Secure the diffuser T to the lower engine bracing tubes with cable ties in position as shown in Fig 330*

- d) Fix the heater control cable into the instrument panel and connect it up to the valve using the cable clamp clip in the kit suitably positioned.

*There is no hard and fast correct position for fitting in the instrument panel, but make sure the cable can follow an unobstructed smooth line down to the valve.*

*Cable inner and outer as supplied should be overlong, and can be trimmed to length. Adjust so that valve closes full – just fractionally before the knob hits its stop.*



**Figure 362 heater control knob example**

## 26. Fitting the storage side pockets

These are storage pockets and fit between the cockpit side and instrument binnacle sides. The fix using velcro – a strip stuck to the instrument binnacle side, and another just below the windscreen fixing nuts. The velcro needs a nice smooth surface to stick to. It won't stick well to the glassfibre. If you have left enough overlap stick it to the lexan below the nuts. Or use a separate strip of thin plastic to apply the velcro to, and then fix that to the cockpit side using the screen fixing screws and nuts – like we did in the middle picture below.



Figure 363 side pocket fixing

## 27 Fitting the Nynja rear thermal screen



Fig 364

- a) The Nynja rear thermal screen consists of a fabric faced foam material that fixes in position with Velcro. The Baggage bag stays in position and is accessed via the zipped opening in the thermal screen. Velcro is applied to the lower sections of the rear cabin tubes SKR.6, and around the rear window aperture.
- b) Prepare the rear screen edges





**Fig 365**

*An edge must be made around the rear window area for the thermal screen to attach to. The kit is supplied with 25x25mm plastic angle for this purpose. It attaches using the same fixing screws as for the rear windows. The plastic angle should be cut with slits every 100mm or so to allow it to adopt the curve of the aperture. Allow a gap to allow full movement of the flap control rod. The edge of the angle should be flush or just below the edge of the window surround. Velcro is attached to its inner face for the thermal screen to attach to.*

## 28. Preparing for Flight

Rig the aeroplane ready to fly.

### 28.1 Airframe

#### Dihedral and washout

The following specifications are intended as a rough indication of the correctness of the alignment of the wings. Unless there is a noticeable deviation from these, such as the presence of anhedral or wash-in, any concerns will be addressed at the test flying stage where the use of different-length lift-strut end-fittings can be used to adjust the wing alignment.

- a) The dihedral should be around  $1.2^\circ$  per wing: a straight line between centre of the leading edge tubes at the wing tips should be around 10cm above the same position at the centre of the cabin.
- b) The washout should be around  $1^\circ$  at the wing tips compared to the wing roots: this corresponds to a twist upwards of around 2cm of the height of the trailing edge over the chord of the wing, from root to tip.

*If this is grossly wrong it is likely that the internal bracing cables are not taught. If either cable is loose the turnbuckle should be tightened. If one of the cables remains slack whilst the other is tight it may be that the covering is not properly seated on the leading edge, requiring removal of the wing covering and refitting as per the instructions.*

### 28.2 Aerofoil Jury struts

- a) Check that the eyebolt attachment in the wings are aligned fore and aft. Rotate if necessary. (note – eyebolts may be either male or female type)
- b) Loosely fit the lower U brackets to the wing lift struts. The horizontal bracing strut should be cut to length, drilled and fitted to the lift struts, with its ends flush with the ends of the brackets.

*The front bracket is the one that leans forwards at an acute angle. The rear bracket is more upright, and should have its most upright edge to the rear.*

- c) Fit the horizontal brace and U brackets as shown, with a thin plastic washer between the U bracket and the lift strut.
- d) Fit the Jury struts and bolt them into position.

*The lower fitting uses a 4-40mm bolt – cut this down to 24mm (measured from under the head to the end of the thread). Thin plastic washers should be put both sides between of the jury strut and U bracket. If it is a male eyebolt the upper fitting has a rubber grommet fitted to the eyebolt to prevent lateral movement, and the Jury strut fits over this. Grommet not required if female eyebolt. It is then fixed with a*

4-35mm bolt (cut this down to 21mm measured from under the head to the end of the thread) and aluminium spacer over the bolt Washers should be used both under the head of the bolt and under the nut of the upper fixing bolts. – or may be superseded with a 6mm bolt.

*Note: If the old type round jury struts are still included in the kit don't be tempted to fit them inside the Aerofoil struts – it is just coincidence that they will go inside!*



**Figure 366 Aerofoil jury strut overview**



**Fig 367 Rear and front lower fittings. Note orientation (looking from front)**





**Figure 368 Rear and front upper fittings.**



**Figure 369 Upper fixing hardware. Note position of rubber grommet (bolt may be superseded with 6mm bolt)**

### **28.3 General checks**

- a) Check that all nuts and bolts are properly tightened and thread-locked.
- b) Check that all bolts subject to rotation in use are correctly split-pinned.
- c) Check that all electrical connections are properly made, with no risk of short-circuiting.
- d) Check that all fuel, oil, and water pipe clips and other connections are properly tightened and sealed.

### **28.4 Baggage Bag**

- a) Remove the plywood base from the baggage bag, and cut a generous notch out of the corner to clear the fuel filler fitting

- b) Loop the rear securing straps around the base of the rear fuselage bracing frame at its lower corners, with the buckle towards the fuel tanks.

*The strap should loop around the back of all the tubes.*



**Figure 370 rear securing strap.**

- c) Pass the upper securing straps around the upper rear fuselage tubes above, but not around, the turnbuckles.

*The straps will have to be slid back down the tubes for them to reach.*

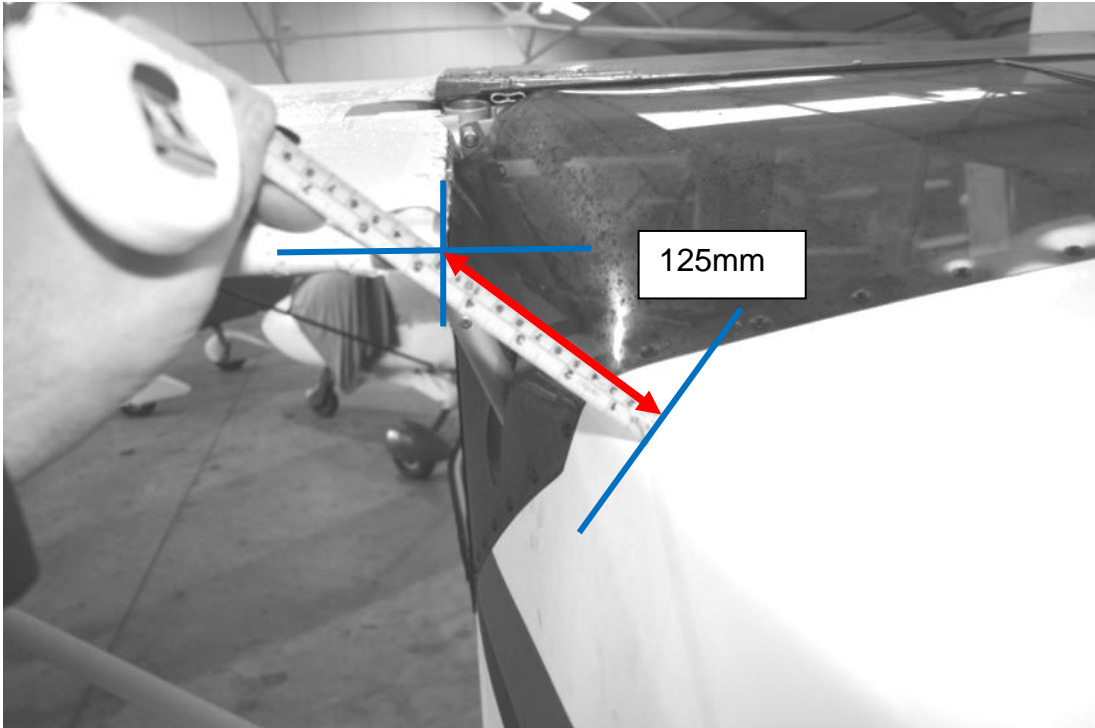
- d) Burn a hole through each strap where the Velcro is, and secure with small pan-head bolts, with the pan-head towards the tube.
- e) Burn holes in the lower Velcro straps and secure with small pan-head bolts.
- f) Connect the lower straps to the rear securing straps using the click-in buckle.

*Note that the lower fixing do not go around the rear cabin uprights TU6. The baggage bag should be free to move upwards and backwards or access to the fuel tank fillers will be restricted.*

## **28.5 Controls**

- a) Mount all the control surfaces and secure with split pins, unless further transportation is to occur.
- b) Check the full and free movement, in the correct sense, of all combinations of the controls.
- c) Check the neutral positions of the flaps and their operation.

*The flaps should be set with the centre of their trailing edges 125mm above the corner of the fuselage fairing*



**Figure 371 flap neutral setting.**

- d) If flaps cannot meet this position with adjuster screwed fully in, of the flap rod can be shortened by redrilling the hole at its lower end where it attached to the stainless angle piece, 20mm above the original hole.
- e) Check the neutral positions and operation of the ailerons.

*Ensure that the stick is kept central whilst adjusting the ailerons.*

*The ailerons should be set with their trailing edges level with those of the flaps.*

*Check that the aileron upward movements are around  $25^\circ$  using a protractor. The downwards movement is less, due to the differential built into the system.*

*If adjustment is needed deflection can be reduced by increasing the diameter of the stops at the torque-tube horn, using tape around the tube to pad-out the stops. If more movement is needed the control horn can be field into a curve where it touches the stop rings.*

- f) Check the tension in the aileron cables.

*It should require around 2kg of force to pull the long aileron cable down at its centre to touch the upper cabin triangle tubes TU10's*

- g) If there is any remaining friction in the aileron control circuit, the fit of the aileron hinges must be checked.

*The ailerons should drop freely under their own weight with the cables detached. If any friction is felt then remove the aileron eyebolt hinges and file the holes in the aileron leading edges until the ailerons move freely. This will greatly improve the feel of the aileron controls.*

*A touch of oil / grease on the hinges works wonders*

- h) Ensure that the tubes which the aileron cables touch are protected by oversized pieces of prop tape or similar.

*There are some small pieces of tubing on the aileron cables. These are fairleads that should be positioned on the top of the TU38 tubes to stop the cables rubbing as they pass over. Hold these in position with two small cable ties. Take care not to flatten the tube with excess cable tie tension.*



**Figure 372 cable guide**

- i) Check the neutral position and operation of the elevator.

*The elevator should be horizontal with the lower half of the stick at 90° to the central cabin tubes, not vertical.*

*Elevator movement should be 25° each way. If necessary file the stop positions on the stick pivot piece to increase movement.*

- j) Ensure the rudder-stop cables have been properly crimped and fitted.
- k) Check the neutral position and operation of the rudder and nose-wheel.

*With the rudder straight, the nose-wheel should be straight. Rudder movement should be 25° each way. Nose-wheel movement should be symmetrical each way.*

- l) Wire-lock all turnbuckles.
- m) Check the correct operation of the brakes.

## **28.6 Powerplant**

### **26.6.1 Fuel tank calibration**

- a) Put a small quantity of fuel into the tanks.
- b) Drain the fuel through the fuel pickup connection.

*Any remaining fuel is roughly the unusable fuel, although it will be affected slightly by the flying attitude.*

- c) Add measured quantities of fuel into the tanks, marking the side of the tanks at 5 litre intervals, starting from zero at the unusable fuel level.

*Allow time for the tank levels to balance before marking each level. This can take a few minutes.*

### **28.6.2 Propeller pitch**

Assemble and fit the propeller following the instructions supplied with the propeller.

Set the propeller pitch to that specified in the HADS for your propeller.

Note that some installations are defined on a max static RPM (5000RPM for 912 and 4850 RPM for 912S installations using the Kiev prop 273 and 283 respectively). This means that once the engine has had its initial run up the propeller pitch may have to be finely adjusted to accurately achieve this. If the RPM is a long way out when the prop is set on its recommended starting pitch, then the RPM gauge may not be indicating accurately and may need calibrating with an optical tachometer (your inspector or local engine service facility should have one).

### **28.6.3 Engine run-up**

Read the engine manual for procedures relating to the first operation of the engine, and subsequent running-in. Follow all requirements for engine and gearbox oil, coolant mix etc. .

It may be advisable to tie the aircraft to a solid structure before any engine power tests, rather than relying on the brakes, particularly on wet grass.

Carburettor balancing on the Rotax engines may be set approximately by comparing the movements of the throttle levers on the carburettors, however for best results the balance should be set by a Rotax engineer familiar with vacuum-gauge balancing.

The Engine Installation Checklist will have to be completed with the assistance of your Inspector.

### **28.6.4 Throttle Friction**

This is adjusted using the two nuts at the port end of the throttle lever torque tube. Set enough friction by tightening the inboard nut to prevent the throttles from vibrating open or closed, then lock this setting with the second nut. Do not set any friction at all on the starboard end of the torque tube.

## 28.6.5 912 Idle Adjustment

The throttles on the 912 engines are sprung to the open position and rely on the cables being pulled taught to achieve the idle setting.

To get a reliable idle setting first loosen the idle adjustment screw(s) on the carburettor(s) – they are **NOT** used to set the idle in this installation!.

The pilots throttle lever has its own stops and its these that set the idle. They are drilled off centre and can be rotated to set the desired idle speed.

However initially set the idle with these stops rotated in a mid way position and lever fully closed against them, by means of adjustment on the cable outers at the carburettor.

Carburettors should also be balanced at this time (specialist engine balance tools exist for this – you can buy them yourself (a good investment if you intend to maintain the engine yourself), or call in a Rotax trained service technician).

When this is complete, check that the idle screws are still adjusted so as not to touch the carburettor levers.

Fine idle adjustment can then be made using the stops on the pilots throttle lever.

If your engine idles with the lever held rearwards, but the RPM springs up significantly when it is released, then the setup is not correct. The most likely causes are:

1. Carburettor levers touching the stops on carbs before the throttle lever touches its stop – wind them well clear!
2. Insufficient throttle lever friction.
3. Too much throttle lever friction (causes a 'stepped' opening and closing)

### **28.6.6 Fuel flow measurement**

This should be performed with the help of your inspector who should have suitable equipment or access to such. Connect a T-piece into the fuel line near the carburettor(s). Connect this to a fuel pressure gauge and a fuel tap, using a length of pipe long enough to reach back into the cockpit.

The fuel flow rate may then be measured: run the engine at full power (aircraft will need stoutly securing for this – and mind the propwash doesn't do any damage to aircraft or objects behind!) with the end of the fuel pipe pointed into a measuring jug in the cockpit, open the tap until the fuel pressure drops to no less than the minimum specified in the engine instructions; measure the time required to bleed off 1 litre of fuel into the measuring jug. Note 1 bar = 100kPa = 15psi roughly.

The excess fuel flow rate is calculated by dividing 3600 seconds by the number of seconds taken for 1 litre. This is required to be greater than 25% of the full power fuel consumption, typically 20-30 litres per hour depending on engine type. Therefore an excess fuel flow rate around 5 litres per hour or greater is required. Much greater flow rates than this minimum are normally found.

An alternative method is to arrange a separate fuel tank to supply the engine by gravity feed, whilst measuring the amount of fuel the pump supplies into a measuring jug beneath the aircraft (use an extension tube on the fuel line, don't try to hit the bucket from the engine!). This then gives the entire fuel flow rate, which must be greater than 125% of the full power fuel flow rate.

## ***28.7 Weight and Balance***

The aircraft will have to be weighed with the assistance of your Inspector, using the information given in the HADS, and using current BMAA format for the report. Note that the weighing attitude is critical on a tall aircraft like the Skyranger, and that bathroom scales are notoriously inaccurate.

## **28.8 Placards**

A number of items require placards as listed in the HADS. A generic placard sheet is supplied including a cable-crossing placard. Apply this to the front vertical tube in sight of the pilots, to show the required crossing of the aileron cables. Do not omit this placard, miss-rigged controls are a common but avoidable problem on any aircraft, and have potentially fatal consequences.

For any other placards, a PC can be used to create and print them out onto paper. Then cover them in an oversize piece of Fablon or similar to hold them in place, this is simple and works well. Alternatively printable adhesive film is available from some computer and office suppliers.

A number of the placards require information gathered during test flying, and so must await its completion.

## **28.9 Test Flying**

### **28.9.1 Paperwork**

- a) See the section on the BMAA homebuilt system at the beginning of this manual.
- b) Register the aircraft with the CAA and fit registration letters.
- c) In case of queries with these BMAA administered procedures, ask your inspector and/or the BMAA.
- d) Read the Pilot's notes.
- e) Ensure that all paperwork is complete. In particular the AW029 needs to be signed by the BMAA Chief Technical Officer and then finally by your inspector. Check that the airfield you intend to fly from has been approved on the form, and that you and the test pilot at least are named on the form

### **28.9.2 Flight Test Day**

With all the paperwork completed the day of the test flight will come!

Test flying any newly constructed aeroplane is a serious business, and should be accomplished with the likelihood of possible emergencies as the major consideration. For this reason the airfield used for test flying should be of generous proportions.

As a guide the field should have a useable runway length of at least 400M without obstructions like wires or buildings on approach or climb-out within another 200M. Surrounding terrain should be such that options exist for all stages of initial climb to altitude to land successfully in the event of an emergency.

It may be tempting to ask the test pilot to fly the aeroplane from the small strip where it has been constructed, and will be based, which may not be ideal for test flying. Please do not put them in the awkward position of having to refuse. The inconvenience of moving the aeroplane to a suitable test flying location is far less than the inconvenience of a rebuild!



A windsock and fire extinguisher on site are essential items. A device for measuring windspeed is desirable.

Some of the test flying will be involved with sorting out a few final adjustments, so make sure you take to the field the following items:

- The +5mm lift strut end (the extra one lying at the bottom of your pile of leftover parts!).

- Lockwire, lockwire pliers and side-cutter pliers.

- General tools (Screwdrivers, spanners etc.)

- Propeller pitch setting tool

- Fuel, in cans to allow choice of fuel load to vary CG position

- Some spare hardware – split pins, nyloc nuts etc.

- All 450kg of associated paperwork!

Refer back to section 1.2 for more information on the paperwork and test flying procedure.

And finally, don't forget your camera to record the moment!

**Happy Flying!**

## 29 Additional Information

### 29.1 Example BMAA Homebuilt Registration Form

#### BMAA - DETAILS OF HOMEBUILT AIRCRAFT PROJECT

BMAA / HB /

*Homebuilt number will be allocated by the BMAA, and will become the aircraft serial number.*

#### Introduction

This form is designed to declare the details of a homebuilt aircraft project to the BMAA. It does not take the place of any other reports that may be requested by the BMAA Technical Office but is essential to clearly show what the planned project is and the source of main parts to be used. Where information is not available or irrelevant leave blank - the BMAA will correspond with you if this data is essential. BMAA will not accept registration of a project until it has been proven a viable microlight aeroplane, if in doubt, check!

*The building of a microlight is not to commence until confirmation of acceptance has been received from the BMAA.*

Note that registration of the aircraft with the CAA will not be possible until it has been given a designation by the BMAA. The appropriate form will be sent to you following registration of the project with the BMAA.

#### 1. Description

(a) Type: SKYDANGER NYNJA	(b) Colour scheme: WHITE	(d) Plans or kit No: UK/BK/001
---------------------------------	-----------------------------	-----------------------------------

If any configuration changes are planned which are not on a currently approved aircraft, please detail this on a separate sheet. There is no extra charge for changes to configuration but please inform the BMAA at the outset wherever possible.

#### 2. Intended Power plant

(a) Engine type / model: ROTAX 912 ULS			
(b) Exhaust: CIT NYNJA	(c) Intake system: K&N FILTERS	(d) Gearing System and ratio: BOX 2.43:1	
(e) Propeller Type: KEVP708283	(f) No. blades: 3	(g) Diameter: 180cm	(h) Pitch: (if known) 35° 233.5cm
(i) Source and any history of engine: NEW			

If an unorthodox engine (e.g. jet, rotary or diesel) is to be used, please describe on a separate sheet(s). BMAA may request detailed further information for any engine or propeller type not previously cleared.

### 3. Owner / Builder's Details

Name: JOE BLOGGS	BMAA No: 001	Home tel: Work tel: Email:
Correspondence address: THE TENT, WINDY AIRFIELD, ON THE HILL. DMG OGG		
Build location: SAME AS ABOVE		

I would like to receive a form BMAA/AW/036 Hardback Aircraft and Engine Logbook (currently £20)

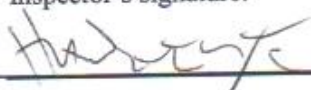

### 4. Nominated Inspector's Details

Inspector must sign below to confirm that they are prepared to inspect this project and have inspected and consider satisfactory the build location / workshop facilities. This must be an inspector, approved by the BMAA Chief Inspector, and who expects to be able to take-on supervision the entire project. On receipt of this form by the BMAA, the Chief Inspector will be consulted as to whether he deems the inspector suitable for the project.

Name: HAWKEYE SMITH	BMAA No: 002 Insp No: 001	Home tel: 0898 771222 Work tel: Email:
Correspondence Address: NOT + BOLTS, SPAN LANE CLEVIS HOLE, LINGS.		

### 5. Checklist

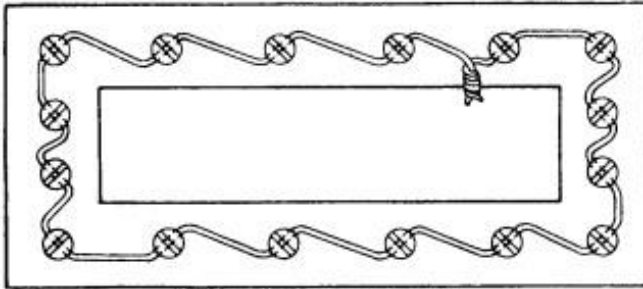
(a)	Form fully completed and signed	
(b)	Copy of kit certificate of conformity (required for registration of series kits)	
(c)	Copy of engine certificate of conformity/provenance (can be supplied later)	
(d)	Copy of propeller certificate of conformity/provenance (can be supplied later)	
(e)	Cheque for project registration fee* (+£20 if you require an aircraft logbook - price subject to change) payable to BMAA	

Inspector's signature: 	Date: 01/01/15	Owner's signature: 	Date: 01/1/15
---	-------------------	--	------------------

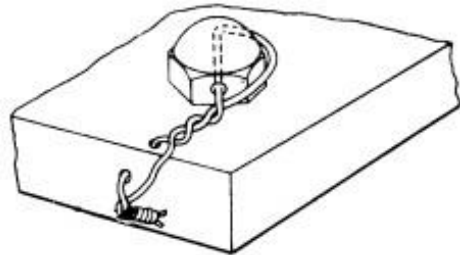
**Note:** You must let the BMAA know if you change inspector or change the configuration of your aircraft. You must get approval before changing inspector.

\* See the latest issue of Microlight Flying for current homebuild project registration fee  
BMAA/AW/022 Issue 7 (Oct 07) Page 2 of 2

## 29.2 Wire-locking



SMALL SCREWS IN CLOSELY  
SPACED CLOSED GEOMETRICAL  
PATTERN  
SINGLE-WIRE METHOD



SINGLE-FASTENER APPLICATION  
DOUBLE-TWIST METHOD



SCREWHEADS  
DOUBLE-TWIST METHOD



EXTERNAL SNAPPING  
SINGLE-WIRE METHOD



BOLTHEADS



CASTLE NUTS

### NOTE

THE SAFETYWIRE IS SHOWN INSTALLED FOR RIGHT-HAND THREADS. THE SAFETYWIRE IS ROUTED IN THE OPPOSITE DIRECTION FOR LEFT-HAND THREADS.

**Section 2. SAFETY METHODS FOR TURNBUCKLES**

**212. GENERAL.** Safety all turnbuckles with safety wire using either the double or single wrap method, or with any appropriately approved special safetying device complying with the requirements of FAA Technical Standard Order TSO-C21. The swaged and unswaged turnbuckle assemblies are covered by AN Standard Drawings. For safety wire sizes and materials, refer to figure 4.22. Do not reuse safety wire. Adjust the turnbuckle to the correct cable tension so that no more than three threads are exposed on either side of the turnbuckle barrel. Do not lubricate turnbuckles.

**213. DOUBLE WRAP METHOD.** Of the methods using safety wire for safetying turnbuckles, the method described here is preferred, although either of the other methods described is satisfactory. The method of double wrap safetying is shown in figure 4.23(A). Use two separate lengths of the proper wire (see figure

4.22). Run one end of the wire through the hole in the barrel of the turnbuckle and bend the end of the wire towards opposite ends of the turnbuckle. Then pass the second length of the wire into the hole in the barrel and bend the ends along the barrel on the side opposite the first. Spiral the two wires in opposite directions around the barrel to cross each other twice between the center hole and the ends. Then pass the wires at the end of the turnbuckle in opposite directions through the holes in the turnbuckle eyes or between the jaws of the turnbuckle fork, as applicable, laying one wire along the barrel and wrapping the other at least four times around the shank of the turnbuckle and binding the laid wires in place before cutting the wrapped wire off. Wrap the remaining length of safety wire at least four turns around the shank and cut it off. Repeat the procedure at the opposite end of the turnbuckle.

When a swaged terminal is being safetyed, pass the ends of both wires, if possible, through the hole provided in the terminal for this purpose and wrap both ends around the shank as described above. When the hole in the terminal is not large enough to accommodate the ends of both wires, the hole may be enlarged in accordance with note 2 of figure 4.22 and the safetying completed as described above. If the hole is not large enough to allow passage of both wires, pass the wire through the hole and loop it over the free end of the other wire, and then wrap both ends around the shank as described.

a. Another satisfactory double wrap method is similar to the above, except that the spiraling of the wires is omitted as shown in figure 4.23(B).

b. The wrapping procedures described and shown on MS 33591 may be used in lieu of the safetying method shown herein.

Cable size	Type of wrap	Diameter of safety wire	Material (annealed condition)
1/16	Single	0.040	Copper, brass. <sup>1</sup>
1/32	Single	0.040	Copper, brass. <sup>1</sup>
1/8	Single	0.040	Stainless steel, Monel and "K" Monel.
1/8	Double	0.040	Copper, brass. <sup>1</sup>
1/8	Single	0.057 min.	Copper, brass. <sup>1</sup>
1/16 and greater.	Double	0.040	Stainless steel, Monel and "K" Monel. <sup>1</sup>
1/32 and greater.	Single	0.057 min.	Stainless steel, Monel or "K" Monel. <sup>1</sup>
1/16 and greater.	Double	0.051 <sup>2</sup>	Copper, brass.

<sup>1</sup> Galvanized or tinned steel, or soft iron wires are also acceptable.  
<sup>2</sup> The safety wire holes in 1/32-inch diameter and larger turnbuckle terminals for swaging may be drilled sufficiently to accommodate the double 0.051-inch diameter copper or brass wires when used.

FIGURE 4.22—Turnbuckle safetying guide.

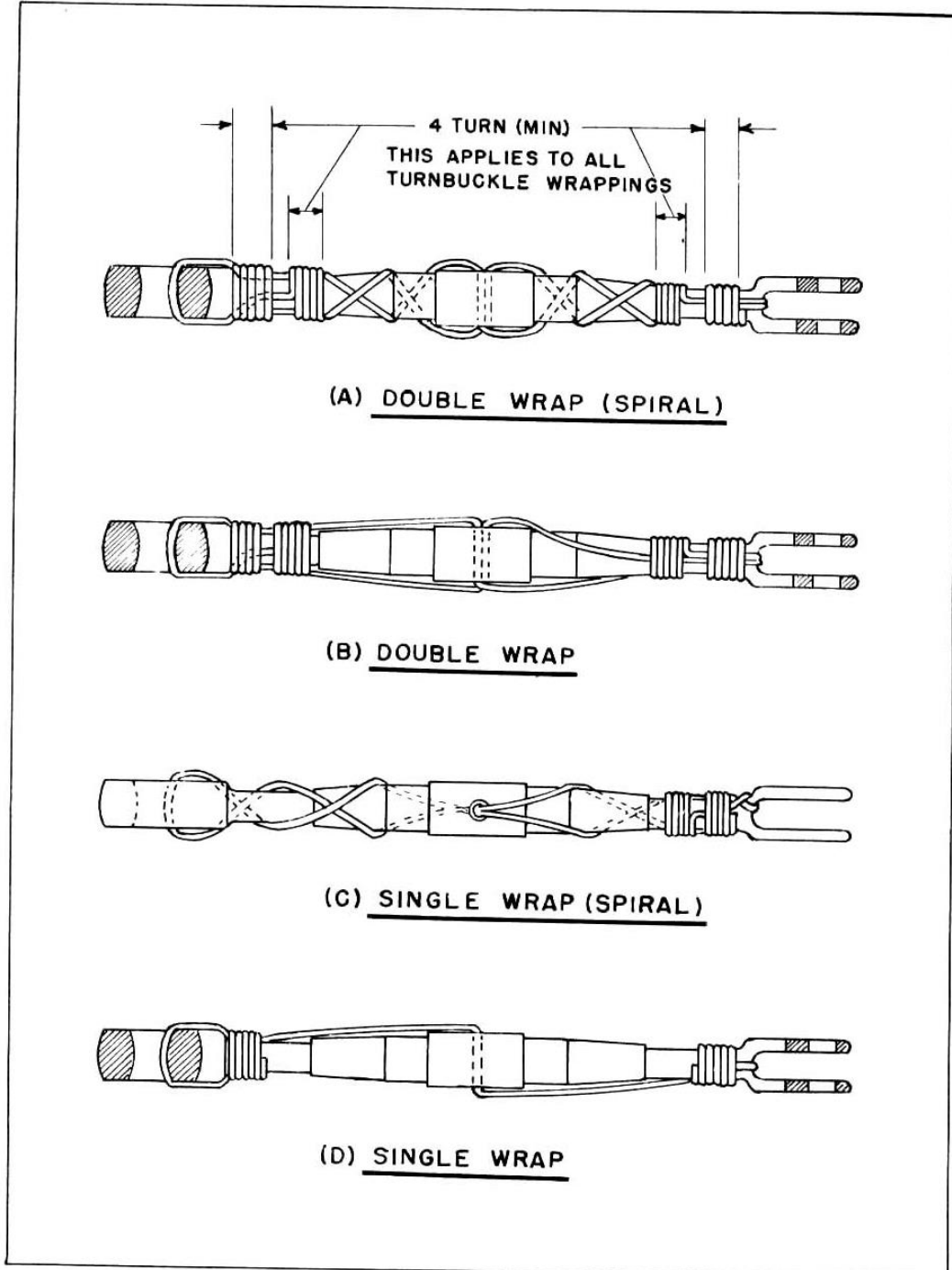


FIGURE 4.23.—Safetying turnbuckles.

**214. SINGLE WRAP METHOD.** The single wrap methods described in the following paragraphs and as illustrated in figures 4.23 (C) and (D) are acceptable but are not the equal of the double wrap methods.

a. Pass a single length of wire through the cable eye or fork, or through the hole in the swaged terminal at either end of the turnbuckle assembly. Spiral each of the wire ends in opposite directions around the first half of the turnbuckle barrel so as to cross each other twice. Thread both wire ends through the hole in the middle of the barrel so that the third crossing of the wire ends is in the hole. Again, spiral the two wire ends in opposite directions around the remaining half of the turnbuckle, crossing them twice. Then, pass one wire end through the cable eye or fork or through the hole in the swaged terminals, in the manner described above, wrap both wire ends around the shank for at least four turns each, cutting off

excess wire. This method is shown in figure 4.23(C).

b. Pass one length of wire through the center hole of the turnbuckle and bend the wire ends toward opposite ends of the turnbuckle. Then pass each wire end through the cable eye or fork, or through the hole in the swaged terminal and wrap each wire end around the shank for at least four turns, cutting off excess wire. This method is shown in figure 4.23(D). After safetying, no more than three threads of the turnbuckle threaded terminal should be exposed.

**215. SPECIAL LOCKING DEVICES.** Several turnbuckle locking devices are available for securing turnbuckle barrels. Persons intending to use a special device must assure the turnbuckle assembly has been designed to accommodate such device. A typical unit is shown in figure 4.24. When special locking devices are not readily available, the use of safety wire is acceptable.

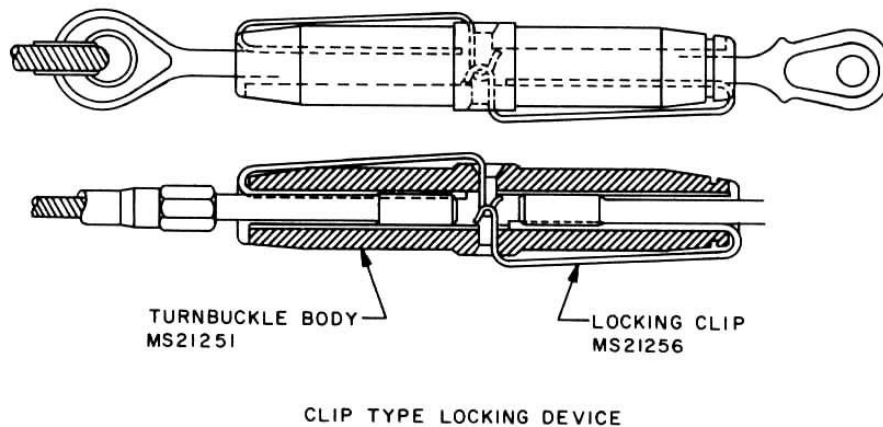


FIGURE 4.24.—Clip type locking device.

**216.-226. RESERVED.**

## 30 Index

aileron control cables, 122  
aileron driving horn, 50  
aileron horn stops, 125  
aileron horns, 119  
aileron pulleys, 31, 114  
alloy side pieces **298**, 41  
aluminium corner section **22**, 63  
axle **tu101**, 75  
battens, 128  
battery, 194  
battery box, 46, 48  
battery terminal boots, 195  
bleed nipples, 78  
BMAA, 12, 185, 192  
bolts, 16  
bracing cable, 117  
bracing frame, 54  
bracing frame **tu39**, 56  
brake discs, 77  
brake lever, 78  
brakes, 77  
bungee cord, 65  
buzzer, 194  
cabin uprights **tu34**, 139  
cables, 83, 90, 122  
callipers, 69  
capacitor, 194  
central brace, 52  
central cabin tubes **tu19**, 39  
compression tubes **tu38**, 131  
control stick, 49  
Copaslip, 159  
covering, 128  
door catch, 212, 222  
door frame, 209  
earth bolt, 194  
earth cable, 195  
electrical system schematics, 187  
elevator stops, 50  
elevator trim tab, 81  
Fablon, 128  
flap handle, 65, 94, 126  
flaps, 126  
Forward Fuselage, **21**  
friction, 228  
front vertical **tu14**, 27  
front vertical tube **tu14**, 31  
fuel drain, 174  
fuel flow, 264  
fuel return pipe, 175  
fuel tank support **tu20**, 64  
fuel tank upper mounting pieces, 36  
fuel tanks, 171  
fuel tap, 174  
fuse box, 193  
grease, 74  
grommets, 76  
hole, 226  
horizontal stabiliser, 83  
intake manifold balancing tube, 166  
jury struts, 112  
leading edge tube **tu49**, 110  
Lexan, 198, 220  
**LOCTITE**, 14  
longitudinal tubes **tu2**, 54  
longitudinal tubes **tu4**, 54



lower cabin triangle tubes **tu12**, 25  
 main undercarriage cross-beam **tu9**, 25  
 modifications, 13  
 oil tank, 161  
 open door keeper, 212, 224  
 part numbering, 18  
 penny washers, 107  
 pitch, 262  
 Pitot, 185  
 pulleys, 91, 122  
 pushrods, 76  
 rear cabin frame cross-tube **tu40**, 36  
 rear cabin frame diagonals **tu27**, 34  
 rear cabin uprights **tu6**, 33  
 rear cable bracket, 82  
**Rear Fuselage, 54**  
 regulator, 195  
 restrictor, 169  
 Rotax 912, 37, 187  
 rubber washers, 73  
 rubbing cables, 98  
 rudder, 89  
 rudder cables, 94  
 rudder centring bungee, 94  
 rudder horn, 87  
 rudder pedals, 48, 76  
 rudder pedals position, 95  
 rudder post, 54  
 rudder stops, 51, 96  
 seat front support tube **tu15**, 47  
 seatbelts, 238  
 seats, 235  
 self-adhesive foam strip, 196  
**Skyranger Hotline, 11**  
 solenoid, 195  
 spacer tube **tu102**, 75  
 spats, 70, 73  
 stainless-steel lower triangulation tubes **tu23**, 43  
 stainless-steel upper triangulation tubes **tu24**, 40  
 steel diagonal brace **tu310**, 41  
 steel diagonal-brace **tu43**, 49  
 steel diagonal-brace **tu43**, 29  
 steel T-piece, 54  
 steel under-seat diagonal tubes **tu42**, 47  
 steering, 75  
 stiff, 120  
 stop-rings, 94  
 stub axle, 70  
 sump, 163  
 tail surfaces, 80  
 tailplane, 63  
 tank securing straps, 173  
 tension, 260  
 tensioning, 80  
 throttle friction, 147  
 throttles, 144  
 tightening bolts, 52  
 torque, 107, 166  
 torque-tube bearing, 50  
 T-piece, 169  
 trailing edge tube **tu50**, 110  
 trim lever, 228  
 trim tab horns, 82  
 trim tabs, 81  
 trimmer cables, 225  
 tube numbering, **2**, 21  
 tube **tu37**, 111

turnbuckle, 84, 117, 129  
twisting cables, 95  
undercarriage, 67  
UP for ON, 194  
upper cabin triangle tubes **tu10**, 31  
upper rear cabin cross-piece **tu7**, 30,  
31  
vertical fin, 80  
water overflow tank, 167  
water pipe, 165  
water pump inlet, 105  
wheels, 67  
windscreen, 139, 196  
wing battens, 135  
wing frame, 130  
wing root, 132  
wing tensioning tubes, 132  
wings, 110  
wings, attaching, 121

## 31. Amendments

Date	Page No.	Change / Addition
		Change to issue 0.2 – tidying of figure numbers and references. Spelling and grammar minor changes. Addition instructions for preparing fairings (page 100). Addition of instructions for small bracing angle in centre of rear fuselage (page 104). Deletion of instructions to fit CDI support bracket. Revision to loctite specification (page 109).
25.02.11		Change to issue 0.3 – Further tidying of figure references. Page 57, correction to rear fuselage attachment reference. Page 78 change to brake line instructions. Page 138, change to Figure 164 caption. Page 144, reference added about cutting throttle torque tube to length. Page 149, additional instructions to cut floor to accept flap detent lever. Page 154, change to figure 190 caption. Page 161-162, change to oil cooler fitting measurements and instructions to correct clearance issues. Page 175, change to jubilee clip securing dashboard supports. Page 220 additional measurements and instructions for trim lever fitting. Page 223-226 changes to console fitting instructions, due to small design change of moulding. Page 242-243, incorporation of heater option fitting instructions. Page 248, additional instructions for flap neutral setting.
10.03.11		Change to issue 1.0. Figure reference correction page 110. Change of oil cooler lateral position and fixing brackets positioning. Change of hose routing from Oil cooler – section 11.2. Change of sequence for fitting upper fin fairing, section 23.2. Change of fixing for cable outlet fairings from rivets to plastic screws – section 23.4. Change of edge distance for rivet holes in wingtips to 40mm, section 23.7.
05.12.11		Change to issue 1.1 tidy up of Figs 53,73,79,85,106 215to prevent possible confusion. Text changes for brake advice, Fuel breather balance pipe, possible incorrect assembly of central frame, fuselage cable tangs,possible incorrect alignment of elevator joiner, Fin forward attach bolt spacer, finding SKR9 and 88 in kit packaging, rudder pedal adjustment, bungee loops, air filters, firewall fixing.
23.12.12		Change to issue1.2 Correction of erroneous reference to firewall in 11.2 c). Explanation of WTG sender fitting 11.3 e). Change of tank filler instructions and pictures to reflect latest arrangement 12.2.4. Correction of position of Cable guide bracket 14 a). Change of heater valve fitting instructions and pictures to reflect latest arrangement 25.. Addition of advice for cutting flap rod exit holes in lexan17.2 d). Correction of fitting method for wing profile blocks 24 c). Change/ removal of parts of Weighing advice to reflect changes to BMAA spreadsheet 26.7.
13.02.13		Change to issue 1.3. Correction of part numbering in various sections. Additional advice for fitting extension tubes for main wheel spats. Change to floor references to reflect new composite floor panel. Correction of plastic washer size to 3mm on Fig66. Removal of old sentence remnant form 3.5b)
28.03.13		Correction of root batten part numbers, correction of picture orientation and hole size guidance for heater fitting.
19.07.14		Change to issue 1.3 - change of build support email. 1.5 – change to add weight info for slipper clutch and large starter. Advice for changing nuts and washers to stainless steel.2.8 – change of sequence for floor fitting for later non flexible composite floor. 2.9 saddle washer sequence adjustment.10.3 – corrected omission of application of intumescent paint.5.4 – additional information for fitment of rudder brace.
07.02.15		Change of contact details, numbering of instrument panel angles, fuel

		line type and position clarification, crimp types, optional mod 33 – large balance pipe, addition of bracing strap for 912ULS, wiring for engines with rotax easy start system, new CHT sender/ coolant temp measuring, metal oil pipe bend, carb heat firewall modification advice, teardrop spat option fitting, side pocket fitment, TU37-54 numbering correction, correction of door pics caption, change to SS heater box, new advice for insertion of upper surface wing tip batten. Commonalisation of VLA lift strut attach plates, renumbering of figs, and replacement / update of many photos. correction to mission of reference to firewall foam, addition of screen drawing, Reclassification as issue 1.4
18.07.15		Incorporation of advice for increasing aileron deflection if required to meet HADS specified angles in 2.8.5 e). Now 1.4b
29.04.16		Correction of fuel tank spreader bar Fig32, new fig 176 to make fixing of throttle pivot plate clearer. 5.4.2 change of text to reflect 3 hinge rudder, and new figs. Fuel tanks – change to incorporate new type strainer, new fig 225.
14.12.16		Update of teardrop spat fixing instructions to reflect change in mounting bracket design. Now 1.4D
09.06.17		Update in wiring section to reflect rationalisation of wiring loom, latest Rotax 900 series engine with head sensors measuring coolant temp, Honeywell Oil pressure senders. Rotax supply of made up leads and plugs for Easy start and oil pressure. Rationalisation of advice for position fitting of Regulator, solenoid and fuse box. Change to clearer pictures in Jury strut section, additional advice not to fit round jury struts inside. Now 1.4E
07.02.18		Change of method of oil cooler fixing for Rotax new type coolers – part number 886002 Now 1.4F
26.02.18		New figs 18-19 and 20 for clarity. Now 1.4G
18.01.2020		Link added to website for electronic manual copies in 1.1. 6.2 h)- ref added for alternative rivnut fixing. 7.3 – advice to use on 912UL added. 8.6 – change of advice for fitting wing covers and tip batten. 18.2.3 correction of door latch fig ref and fixings. 18.3.2 – correction to hinge detail. 20 – advice added for centre console (new shape). 22 – Deletion of old style spats section. Correction of hole positions for cut out. 27 – section added for fitting rear thermal screen option. 28.2 – detail added to jury strut bolt lengths and rear bracket orientation. Re-format of Contents section and index. Now 1.4H
23.11.2020		Additional advice for central braces – pages 52-53 Fig69 – picture of LS SKR.20 added Fig72 – new picture of flap handle showing Z bend Section12 – new fuel system schematic drawing and revised breather system. Fuel piping revised for X connector. 12.8 correction to fuel filler hole size. Section 14 – push-pull throttle instructions added, old throttle deleted Section 17 – fig290 – screen rear moulding channel introduced. Rationalisation of rear window fixing methods. Fig 314 – new pictures of

		door hinges. Section19 – trimmer lever dimensions revised and new pictures. Now 1.4I
--	--	--